

# Autotrol Magnum 293-298 Logix 764



## **IMPORTANT SAFETY INSTRUCTIONS**

Read and follow all instructions  
Save these instructions

[WWW.PENTAIR.EU](http://WWW.PENTAIR.EU)  
[WWW.PENTAIR.COM](http://WWW.PENTAIR.COM)

# Table of Contents

<b>1</b>	<b>Generalities .....</b>	<b>6</b>
1.1	Scope of the documentation .....	6
1.2	Release management .....	6
1.3	Manufacturer identifier, product identification .....	6
1.4	Abbreviations used.....	7
1.5	Norms.....	7
1.5.1	Applicable norms .....	7
1.5.2	Available certificates.....	7
1.6	Procedure for technical support .....	8
1.7	Copyright and Trademarks .....	8
1.8	Limitation of liability .....	8
<b>2</b>	<b>Safety.....</b>	<b>9</b>
2.1	Safety pictograms definition .....	9
2.2	Serial label location .....	10
2.3	Hazards .....	10
2.3.1	Personnel.....	11
2.3.2	Material .....	11
2.4	Hygiene and sanitization .....	11
2.4.1	Sanitary issues .....	11
2.4.2	Hygiene measures .....	12
<b>3</b>	<b>Description .....</b>	<b>13</b>
3.1	Introduction to the Magnum Cv and Magnum IT valves series.....	13
3.2	Technical specifications.....	14
3.3	Performance flow rate characteristics .....	15
3.4	Outline drawing.....	16
3.5	Components description and location.....	17
3.6	Options available on the valve .....	18
3.6.1	Refill first.....	18
3.6.2	External pilot feed adapter .....	18
3.6.3	Magnum switch kit.....	19
3.7	Softener operating mode .....	24
3.7.1	298 Valves (5 - Cycle softener).....	24
3.7.2	293 Valves (3 - Cycle filter) .....	26
<b>4</b>	<b>System sizing.....</b>	<b>27</b>
4.1	Recommendations .....	27
4.1.1	Injector and Refill controller charts .....	27
4.1.2	Drain line flow control .....	27

4.1.3	Recommended backwash flow rates for various media .....	29
4.2	Cycle time calculation .....	29
4.3	Injector flow rates .....	29
4.4	Standard efficiency exchange capacity.....	32
<b>5</b>	<b>Installation .....</b>	<b>33</b>
5.1	Product identification.....	33
5.2	Safety notices for installation .....	33
5.3	Installation environment.....	34
5.3.1	General.....	34
5.3.2	Water.....	34
5.3.3	Electrical .....	34
5.3.4	Mechanical .....	35
5.3.5	Outdoor Locations.....	35
5.4	Integration constraints .....	36
5.5	Block diagram and configuration example .....	37
5.6	Valve on tank assembly .....	40
5.7	Valve connection to piping .....	40
5.7.1	Top-mounted valve installation .....	40
5.7.2	Side-mounted valve installation .....	42
5.8	Connections (electrical) .....	43
5.8.1	Wiring diagrams.....	43
5.9	Bypassing.....	44
5.10	Drain line connection .....	45
5.11	Overflow line connection.....	46
<b>6</b>	<b>Programming .....</b>	<b>48</b>
6.1	Display.....	48
6.2	Commands .....	50
6.2.1	Programming overview.....	50
6.3	Basic programming 764 controller .....	51
6.3.1	Program valve and system types.....	51
6.3.2	Program system size .....	52
6.3.3	Time setting.....	52
6.3.4	Day of week .....	52
6.3.5	Regeneration time.....	52
6.3.6	Days override .....	53
6.3.7	Amount of salt used per regeneration.....	53
6.3.8	Estimated capacity .....	53
6.3.9	Hardness.....	53
6.4	Advanced programming.....	54
6.4.1	Basic programming parameters (5 - Cycle softener system) .....	54
6.4.2	Advanced programming parameters (5 - Cycle softener system).....	55
6.4.3	Basic programming parameters (3 - Cycle filter system) .....	56

6.4.4	Advanced programming parameters (3 - Cycle filter system).....	56
6.4.5	Cycle time programming .....	58
6.4.6	Diagnostic.....	59
6.4.7	Resetting the controller.....	60
<b>7</b>	<b>Commissioning .....</b>	<b>61</b>
7.1	Water filling, draining and watertightness inspection .....	61
7.1.1	System started .....	61
7.1.2	Additional tips.....	63
7.2	Sanitization.....	63
7.2.1	Disinfection of water softeners.....	63
7.2.2	Sodium or calcium hypochlorite.....	63
<b>8</b>	<b>Operation.....</b>	<b>65</b>
8.1	Recommendations .....	65
8.2	Manual regeneration .....	65
8.3	To advance regeneration cycles .....	65
8.4	To cancel a regeneration .....	65
<b>9</b>	<b>Maintenance .....</b>	<b>66</b>
9.1	293-298 CV / IT: General system inspection.....	66
9.1.1	Water quality .....	66
9.1.2	Mechanical checks.....	66
9.1.3	293 Regeneration test.....	67
9.1.4	298 Regeneration test.....	67
9.2	293-298 CV / IT: Recommended maintenance plan .....	67
9.3	298 CV / IT: General system inspection .....	69
9.3.1	Water quality .....	69
9.3.2	Mechanical checks.....	69
9.4	Recommendations .....	70
9.4.1	Use original spare parts .....	70
9.4.2	Use original approved lubricants.....	70
9.4.3	Maintenance instructions .....	70
9.5	Cleaning and maintenance .....	71
9.5.1	First steps .....	71
9.5.2	Injector cleaning.....	71
9.5.3	Refill controller cleaning .....	71
9.5.4	Pilot filter screen cleaning.....	73
9.5.5	Controller cover disassembly.....	74
9.5.6	Camshaft cover disassembly.....	74
9.5.7	Motor replacement .....	75
9.5.8	Camshaft replacement .....	76
9.5.9	Optical sensor and controller replacement .....	77
9.5.10	Turbine cleaning or replacement .....	78
9.5.11	Top plate and disc valve replacement .....	79
9.5.12	Cartridge replacement.....	81

<b>10</b>	<b>Troubleshooting .....</b>	<b>83</b>
10.1	Logix controller .....	83
10.2	Magnum IT and Cv valve .....	85
10.3	Magnum valve cartridge .....	87
<b>11</b>	<b>Spare parts .....</b>	<b>89</b>
11.1	Magnum connections .....	89
11.2	Magnum Logix camshaft and pilot .....	90
11.3	Magnum refill controller assembly .....	91
11.4	Magnum injector assembly .....	92
11.5	Magnum drain line flow controls assembly .....	93
11.6	Magnum cartridges .....	94
11.7	Magnum Logix controllers .....	95
11.8	Magnum IT turbine .....	96
11.9	2" external turbine assembly .....	96
11.10	Magnum miscellaneous .....	97
11.11	Magnum 293/298 installation components .....	98
<b>12</b>	<b>Disposal .....</b>	<b>99</b>

# 1 Generalities

## 1.1 Scope of the documentation

The documentation provides the necessary information for appropriate use of the product. It informs the user to ensure efficient execution of the installation, operation or maintenance procedures.

The content of this document is based on the information available at the time of publication. The original version of the document was written in English.

For safety and environmental protection reasons, the safety instructions given in this documentation must be strictly followed.

The manufacturer reserves the right to make changes at any time without notice.

This manual is a reference and will not include every system installation situation. The person installing this equipment should have:

- training in the Autotrol series, Logix 764 controllers and water treatment appliances installation;
- knowledge of water conditioning and how to determine proper controller settings;
- basic plumbing skills.

This document is available in other languages on <https://www.pentair.eu/product-finder/product-type/control-valves>.

## 1.2 Release management

Revision	Date	Authors	Description
A	28.01.2026	STF / EPL	First edition.

## 1.3 Manufacturer identifier, product identification

	<b>EMEA legal entity</b>	<b>NAM legal entity</b>
Manufacturer:	Pentair Manufacturing Italy S.R.L. Via Tiziano 32 20145 Milano (MI) Italy	Pentair Water Solutions 13845 Bishops Drive, Suite 200 Brookfield, WI 53005 United States

Assembled in the factory: Pentair Manufacturing Italy  
Via Masaccio 13  
Lugnano di Vicopisano 56010 (PI),  
Italy

Product identification: Autotrol Magnum 293-298 Logix 764

## 1.4 Abbreviations used

BLFC	Brine Line Flow Controller
DF	Down Flow
DLFC	Drain Line Flow Controller
Inj	Injector
QC	Quick Connect
Regen	Regeneration
SBV	Safety Brine Valve
TC	Time Clock
UF	Up Flow

## 1.5 Norms

### 1.5.1 Applicable norms

#### For EMEA:

Comply with the following guidelines:

- 2014/35/UE: Low Voltage Directive;
- 2014/30/UE: Electromagnetic compatibility;
- 2011/65/UE: Restriction of use of certain hazardous substances in electrical and electronic equipment (RoHS);
- UNI EN ISO9001.

Meets the following technical standards:

- EN IEC 61326-1;
- EN IEC 61010-1.

#### For NAM:

Comply with the following guideline:

- UL 979.

### 1.5.2 Available certificates

#### For Europe

- CE;
  - DM174;
  - ACS.
- Please find beside the certifications for some of our product families. Please note that this list is not an exhaustive list of all our certifications. In case of need for more information please contact us.



#### For North America

- UL.

## 1.6 Procedure for technical support

Procedure to follow for any technical support request:

1. Collect the required information for a technical assistance request.
  - ⇒ Product identification (see Serial label location [→Page 10] and Recommendations [→Page 70]);
  - ⇒ Description of the device problem.
2. Please refer to the Troubleshooting [→Page 83]. If the problem persists contact your local tech support.

**EMEA:** Contact your local tech support

**NAM:** Phone: 1-800-279-9404

tech-support@pentair.com

## 1.7 Copyright and Trademarks

All indicated Pentair trademarks and logos are property of Pentair. Third party registered and unregistered trademarks and logos are the property of their respective owners.

© 2026 Pentair. All rights reserved.

## 1.8 Limitation of liability

Pentair Water Treatment products benefit, under specific conditions, from a manufacturer warranty that may be invoked by Pentair's direct customers. Users should contact the vendor of this product for applicable conditions and in case of a potential warranty claim.

Any warranty provided by Pentair regarding the product will become invalid in case of:

- installation done by a non-water-professional;
- improper installation, improper programming, improper use, improper operation and/or maintenance leading to any kind of product damages;
- improper or unauthorized intervention on the controller or components;
- incorrect, improper or wrong connection/assembly of systems or products with this product and vice versa;
- use of a non-compatible lubricant, grease or chemicals of any type and not listed by the manufacturer as compatible for the product;
- failure due to wrong configuration and/or sizing.

Pentair accepts no liability for equipment installed by the user upstream or downstream of Pentair products, as well as for process/production processes which are installed and connected around or even related to the installation. Disturbances, failures, direct or indirect damages that are caused by such equipment or processes are also excluded from the warranty. Pentair shall not accept any liability for any loss or damage to profits, revenues, use, production, or contracts, or for any indirect, special or consequential loss or damage whatsoever. Please refer to the Pentair List Price for more information about terms and conditions applicable to this product.

## 2 Safety

### 2.1 Safety pictograms definition

#### DANGER



This combination of symbol and keyword indicates an imminently hazardous situation that will result in serious or fatal injury if not avoided.

#### WARNING



This combination of symbol and keyword indicates a potentially hazardous situation that can result in serious or fatal injury if not avoided.

#### CAUTION



This combination of symbol and keyword indicates a potentially hazardous situation that can result in minimal or minor injury if not avoided.

#### Caution - material



This combination of symbol and keyword indicates a potentially hazardous situation that can result in material damage if not avoided.

#### Prohibition



Mandatory advice to follow.

#### Mandatory



Applicable guideline, measure.

#### Info



Informative comment.

## 2.2 Serial label location

### EMEA

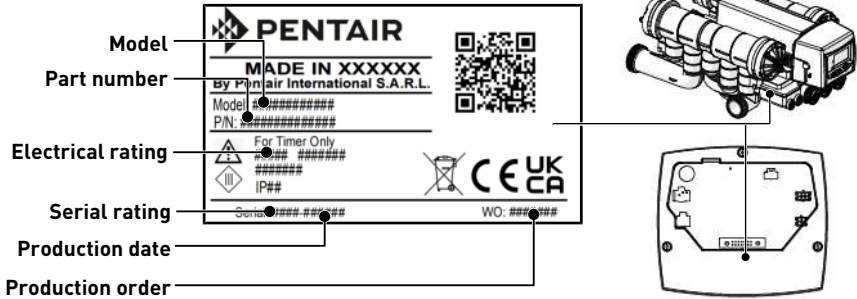

### NAM

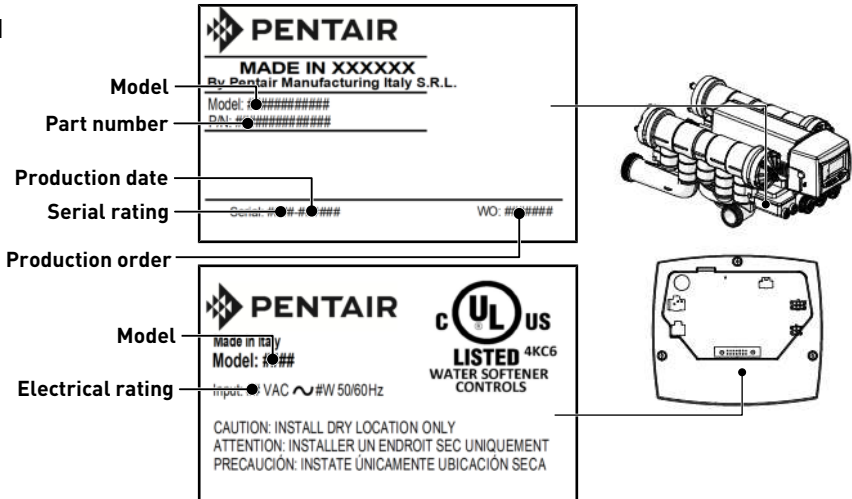

#### Mandatory



**Ensure that the serial label and the safety labels on the device are completely legible and clean!**

## 2.3 Hazards

All the safety and protection instructions contained in this document must be observed in order to avoid temporary or permanent injury, damage to property or environmental pollution.

At the same time, any other legal regulations, accident prevention and environmental protection measures, as well as any recognized technical regulations relating to appropriate and risk-free methods of working which apply in the country and place of use of the device must be adhered to.

Any non-observation of the safety and protection rules, as well as any existing legal and technical regulations, will result in a risk of temporary or permanent injury, damage to property or environmental pollution.

This product is not intended to be used for treating water that is microbiologically unsafe or of unknown quality without adequate disinfection before or after the product.

### 2.3.1 Personnel

#### CAUTION



#### **Risk of injury due to improper handling!**

Only qualified and professional personnel, based on their training, experience and instruction as well as their knowledge of the regulations, safety rules and operations performed, are authorized to carry out necessary work.

#### WARNING



#### **Appliance**

This appliance can be used by children aged from 8 years and above and persons with reduced physical, sensor or mental capabilities or lack of experience and knowledge if they have been given supervision or instruction concerning use of the appliance in a safe way and understand the hazards involved.

#### WARNING



#### **Children**

Children shall not play with the appliance.

Cleaning and salt refill shall not be made by children without supervision.

#### **Mandatory**



**Any other maintenance operation must be carried out only by qualified and professional personnel!**

### 2.3.2 Material

The following points must be observed to ensure proper operation of the system and the safety of user:

- be careful of high voltages present on the transformer (230 V, 50 Hz);
- do not put your fingers in the system (risk of injuries with moving parts and shock due to electric voltage).

## 2.4 Hygiene and sanitization

### 2.4.1 Sanitary issues

#### **Preliminary checks and storage**

- Check the integrity of the packaging. Check that there is no damage and no signs of contact with liquid to make sure that no external contamination occurred;
- the packaging has a protective function and must be removed just before installation. For transportation and storage, appropriate measures should be adopted to prevent the contamination of materials or the objects themselves.

## Assembly

- Assemble only with components which are in accordance with drinking water standards;
- after installation and before use, perform one or more manual regenerations in order to clean the media bed. During such operations, do not use the water for human consumption. Perform a disinfection of the system in the case of installations for treatment of drinking water for human use.

### Info



**This operation must be repeated in the case of ordinary and extraordinary maintenance.**

It should also be repeated whenever the system remains idle for a significant time.

### Info



**Valid only for Italy**

In case of equipment used in accordance with the DM25, apply all the signs and obligations arising from the DM25.

## 2.4.2 Hygiene measures

### Disinfection

- The materials used for the construction of our products meet the standards for use with potable water; the manufacturing processes are also geared to preserving these criteria. However, the process of production, distribution, assembly and installation, may create conditions of bacterial proliferation, which may lead to odor problems and water contamination;
- it is therefore strongly recommended to sanitize the products. See Sanitization [[→Page 63](#)];
- maximum cleanliness is recommended during the assembly and installation;
- for disinfection, use Sodium or Calcium Hypochlorite and perform a manual regeneration.

### 3 Description

#### 3.1 Introduction to the Magnum Cv and Magnum IT valves series

The Magnum valve is available in several configurations:

	Magnum Cv	Magnum IT
Turbine	External turbine	Internal turbine
Inlet diameter	1 1/2" (3.91 cm)	2" (5.08 cm)
Outlet diameter	1 1/2" (3.91 cm)	2" (5.08 cm)
Drain diameter	1 1/2" (3.91 cm)	1 1/2" (3.91 cm)

Logix Magnum Time Clock 764/298 Logix Magnum Demand 764/298	Logix Magnum Time Clock 764F/293 Logix Magnum Demand 764F/293
5 - Cycle softener	3 - Cycle filter
C0: Service C1: Backwash C2: Brine draw C3: Slow rinse C5: Fast rinse C8: Refill	C0: Service C1: Backwash C5: Fast rinse

**Info**



**Both valves configuration [293 & 298] are available with Magnum Cv and Magnum IT series.**

**Magnum Cv**

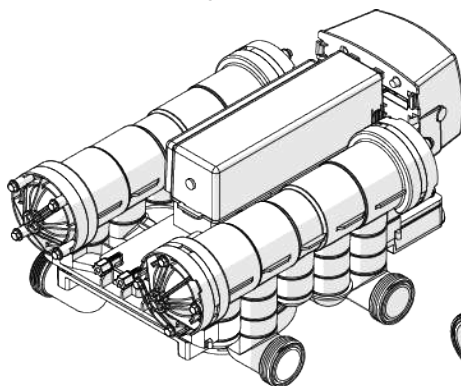

**Magnum IT**

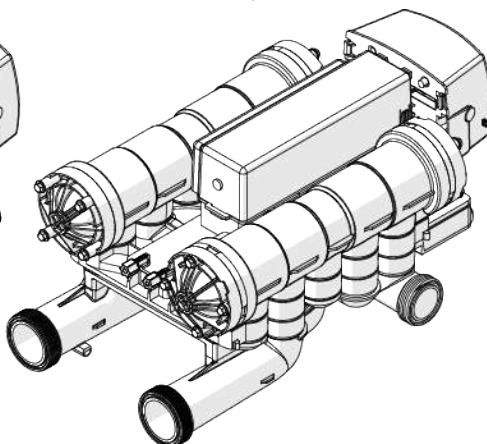

## 3.2 Technical specifications

### Design specifications/ratings

Valve body	PPO Glass fiber reinforced
O-rings	EPDM
Weight (valve with controller)	23.37 lbs (10.6 kg)
Recommended operating pressure	20 to 125 psi (1.4 to 8.62 bar – 0.14 to 0.86 MPa)
Hydrostatic test pressure	300 psi (20.69 bar) (2.07 MPa)
Water temperature	38 to 100°F (1 to 35°C)
Ambient temperature	37 to 104°F (3 to 40°C)

### Flow rates Magnum Cv (valve only)

Service at 15 psi (1.03 bar) drop	76 gpm (17.3 m <sup>3</sup> /h)
Backwash at 25 psi (1.72 bar) drop	89 gpm (20.2 m <sup>3</sup> /h)
Service	Kv = 17 m <sup>3</sup> /h (Cv = 19.5 gpm)
Backwash	Kv = 15.4 m <sup>3</sup> /h (Cv = 17.8 gpm)

### Flow rates Magnum IT (valve only)

Service at 15 psi (1.03 bar) drop	80 gpm (18.2 m <sup>3</sup> /h)
Backwash at 25 psi (1.72 bar) drop	89 gpm (20.2 m <sup>3</sup> /h)
Service	Kv = 79 gpm (17.94 m <sup>3</sup> /h) Cv = 20.74 gpm (4.71 m <sup>3</sup> /h)
Backwash	Kv = 67.8 gpm (15.4 m <sup>3</sup> /h) Cv = 17.8 gpm (4.04 m <sup>3</sup> /h)

### Valve connections

Tank Adapter Thread	4" – 8 UN
Inlet/Outlet Threads	1.5" Connections NPT or BSPT, Female, CPVC
Drain line*	1 ½" Connections for NPT or BSPT, Female, CPVC
Brine line	¾" NPT
Riser tube [Ø]	1 ½" O.D.
Riser installation	Above top of tank 5/8 ± 1/8" (16 mm ± 3 mm)
Pilot drain and auxiliary hydraulic output	¼" (6.4 mm) tube fitting

\* Valve installed drain flow controls available (5 to 40 gpm) (1.14 to 9.08 m<sup>3</sup>/h). If higher backwash flow is needed, an external flow control will be required.

**Electrical**

Controller Operating Voltage**	12 VAC (requires use of Pentair Water supplied transformer)
Input Supply Frequency	50 or 60 Hz (controller configuration dependent)
Motor Input Voltage**	12 VAC
Controller Power Consumption	8 W average
Protection rating	IP23

\*\* Temporary overvoltage must be limited both in duration and frequency.

**3.3 Performance flow rate characteristics**

The graph shows the pressure drop created by the valve itself at different flow rates. It allows predetermining the maximum flow rate going through the valve depending on the system settings (inlet pressure etc). It also allows to determine the valve pressure drop at a given flow rate, and therefore to evaluate the system pressure drop vs flow rate.

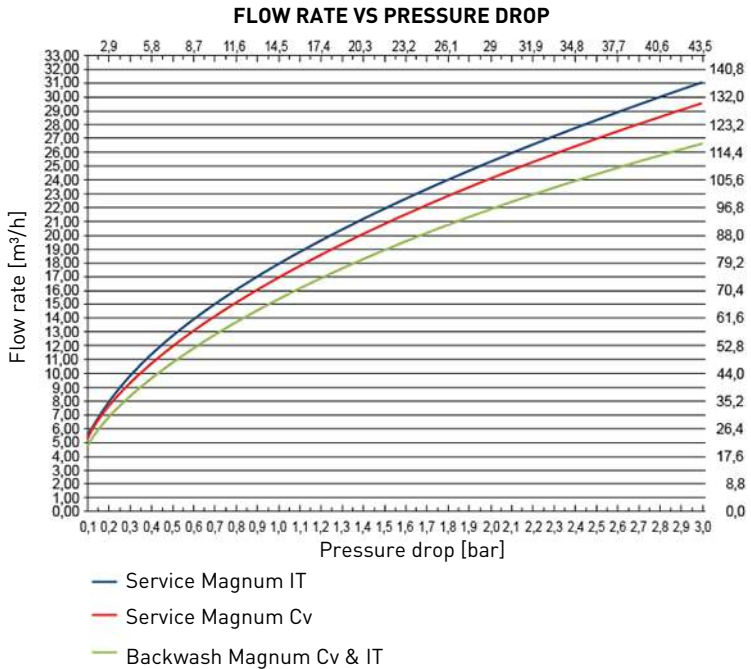

### 3.4 Outline drawing

**Magnum Cv**

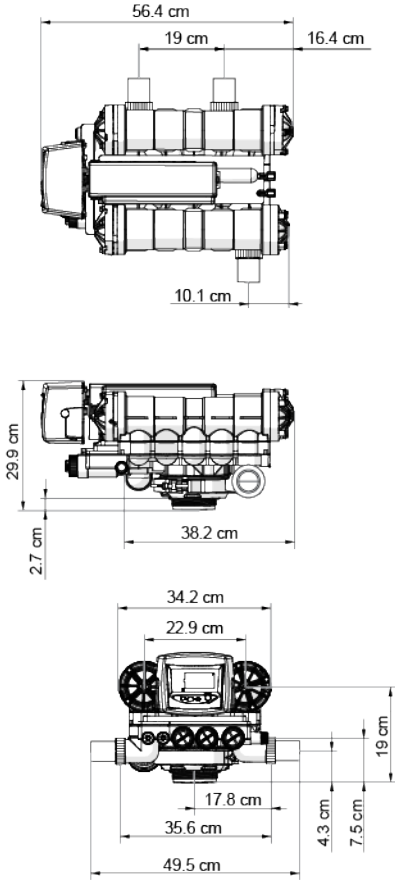

**Magnum IT**

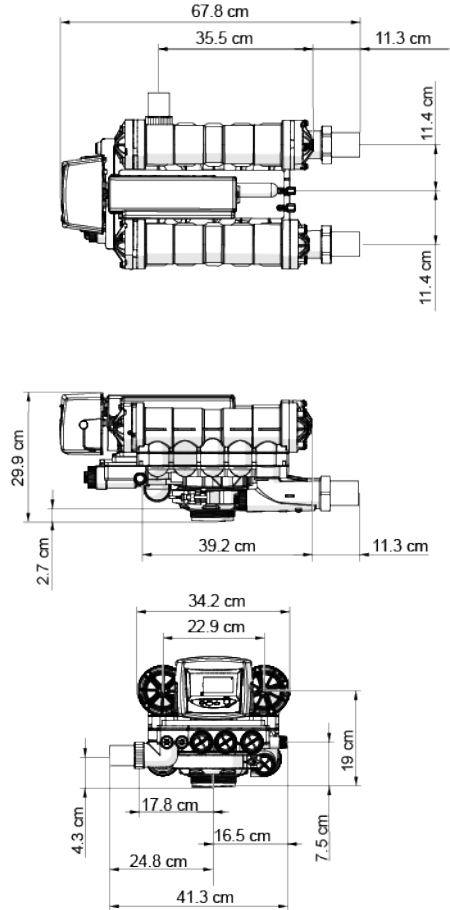

### 3.5 Components description and location

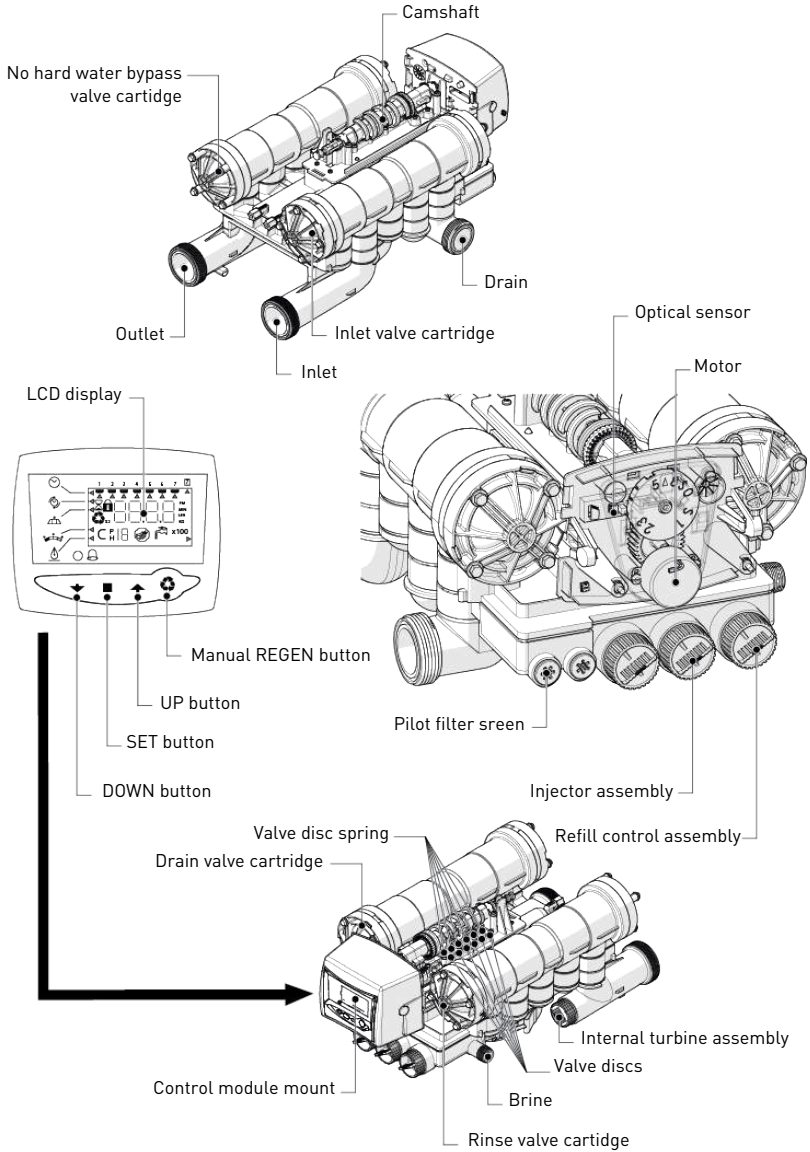

## 3.6 Options available on the valve

### 3.6.1 Refill first

The Logix 764 controllers allow you to refill the brine tank first when used in softener mode. This feature allows the brine tank to be dry during the complete service cycle, reducing the caking phenomena.

When a regeneration is initiated, the timer places the valve in refill position. Once the refill cycle is done, the timer puts the valve back into service for 2 hours giving a sufficient time to make the brine in the brine tank. After 2 hours the softener will operate a regeneration as usual, just skipping the refill cycle that will be done just before the next regeneration cycle.

### 3.6.2 External pilot feed adapter

A small check valve is incorporated inside the Magnum pilot system. This removable and replaceable check valve maintains the valve cartridge position in the event of pressure loss.

This check valve is compatible with an external pilot feed adapter and can be used with separate source pilot pressure if desired.

1. Remove the pilot filter screen assembly **(1)**.
2. Install the external pilot feed adapter **(2)** or the pilot system check valve **(3)**.

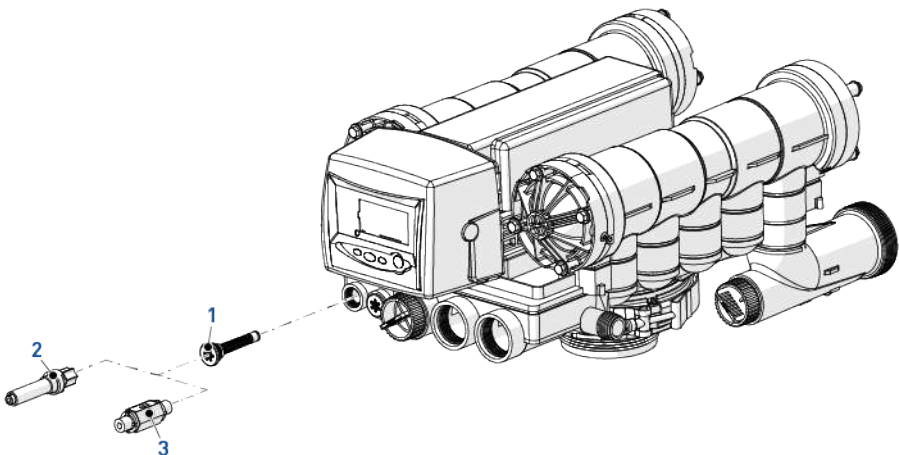

### 3.6.3 Magnum switch kit

Optional switch kits can be used on the Magnum Cv valve to provide electrical signalling capabilities. Used in conjunction with breakaway cams, the switches will provide a signal to external devices during the various cycles of the valve operations.

#### 3.6.3.1 Switch mounting instructions

1. Fasten the switch-mounting bracket (4) to the Magnum Cv valve (1) using the threadforming mounting screw (3) (see picture 1). The shorter, clipped edge of the bracket should be positioned over the guide pin (5) and screw hole located behind the B1/B2 cam (2/6).
2. Attach the switches to the bracket using the screws, nuts and washers provided. The screws should be inserted so that the washer and nuts are on the backside of the switch SW1. When mounting a single switch, the switch is mounted to the back of the bracket directly in front of the number one cam (see picture 1).  
When a triple switch is mounted, one switch is located on the back of the bracket and two are located on the front (see picture 2). For multiple switches it is easiest to slide two switches onto the screws and then insert the screws through the bracket. The final switch is then added to the screws and fastened with the washers and nuts (see picture 2). Switches are mounted with the switch arm adjacent to the breakaway cams and the electrical contacts directed away from the camshaft (see picture 3).
3. Each switch has three terminals (see picture 4), the common terminal is on the side (labelled COM1), and two terminals are on the bottom.  
The lower terminal which is closest to the camshaft is the closed contact (labelled NC2), the remaining terminal is the open contact (labelled NO3).  
Connect the cable lead wires to the appropriate terminal using the crimp-on terminal connectors provided. The connections for these cables are: black to common terminal, red to normally open terminal and green to normally closed terminal.

Picture 1

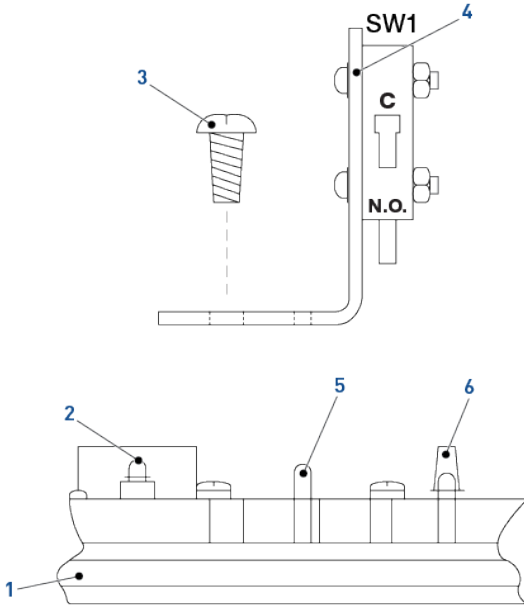

Picture 2

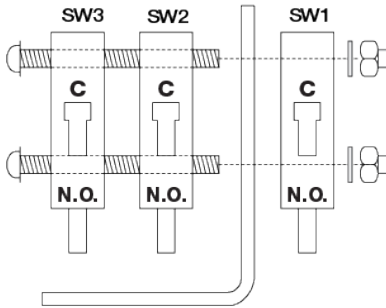

Picture 3

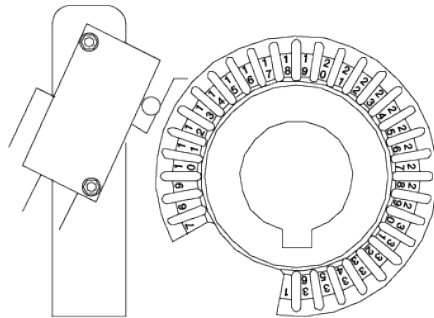

Picture 4

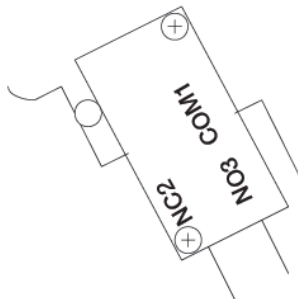

### 3.6.3.2 Breakaway switch cam description

The breakaway switch cam has been divided into 36 equal sections with each section representing approximately 10-degrees of the cam rotation. Each section is consecutively numbered 1 through 36 to aid in customized cam operating design.

Each cam section, as well as the outside ring of the cam that the switch arm rides on, is molded of a high strength, co-polymer resin. Although a single cam section is strong enough to operate the switch, it is recommended that a minimum of three continuous cam sections always be incorporated into the cam timing design for the on/off operation of the switch. Likewise, it is recommended that a minimum of three cam sections be removed to ensure the proper on/off operation of the switch.

**Caution - material**



**The breakaway switch cam (P/N 1034356) cannot be used as a substitute for any standard Magnum Cv Series pilot cam lobe.**

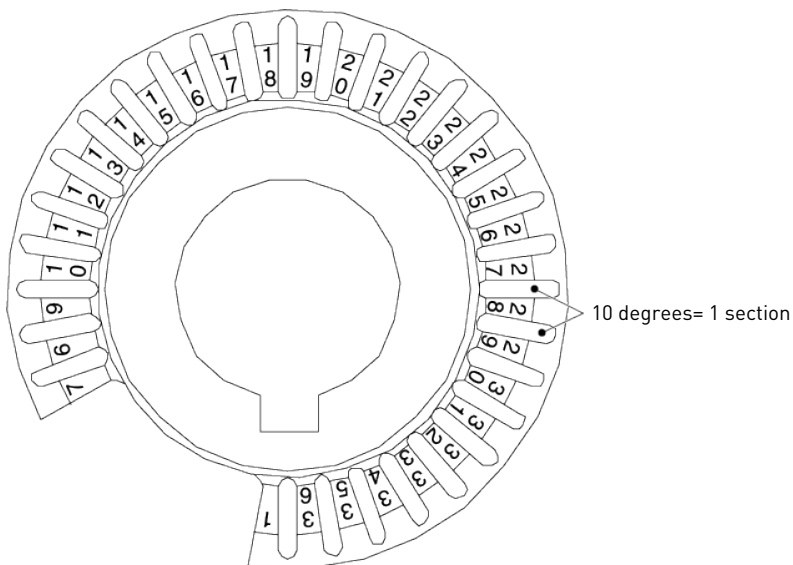

### 3.6.3.3 Breakaway switch cam instructions

Based on the system requirements and the external devices used, determine the program timing, i.e., when the external devices need to operate, either open or close.

Typical external devices would be solenoids, solenoid operated diaphragm valves, relays, and chemical feed pumps. Using the instructions below, sections can be removed from the breakaway cam to allow signalling during the desired cycles. One cam can be used to signal multiple non-contiguous cycles.

1. Determine which breakaway cam sections need to be removed using the chart below. In order to assure that switch deactivation occurs, at least three sections must be removed from the breakaway switch cam.  
The sections should be removed in a clockwise fashion, starting with the first number and ending with the second [see picture 1]. Utilizing the timing chart on the back, determine if the switch arm should be riding on the cam [actuated] or not [relaxed].

**Tip**



**Remember that the switch operates either normally open or normally closed depending upon how it is wired.**

2. Using diagonal cutters or a razor knife, cut through the cam on either side of the section you wish to remove. The breakaway cam section should be trimmed to the edge of the section which is to remain on the breakaway cam, see picture 2. Cut the outside ring first, then at the score line on the bottom of each section near the center ring.

**Tip**



**When starting to remove sections, start two or three sections before the section required.**

Then remove one section at a time until the required section is reached. This procedure eliminates the potential of damage to usable sections.

3. When all of the desired sections have been removed, add the breakaway switch cam(s) to the camshaft after the B1/B2 pilot cam.  
The switch cam can be installed onto the camshaft in only one direction. The numbers on the breakaway switch cam should face the controller.
4. Replace the standard pilot cams in the proper order and reinstall the camshaft onto the control valve. Refer to Motor replacement [→Page 75] for instructions on the removal and replacement of the camshaft assembly.

Cycle	Section numbers
Service (C0)	19, 20, 21, 22, 23, 24, 25
Backwash (C1)	26, 27, 28, 29, 30, 31, 32
Brine (C2)	33, 34, 35, 36, 1
Slow rinse (C3)	2, 3, 4, 5, 6, 7, 8, 9, 10
Fast rinse (C5)	11, 12, 13, 14
Refill (C8)	15, 16, 17, 18

Picture 1

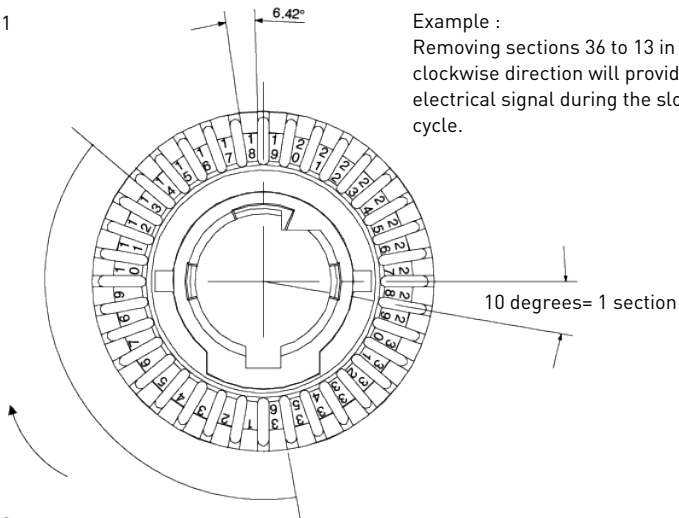

Picture 2

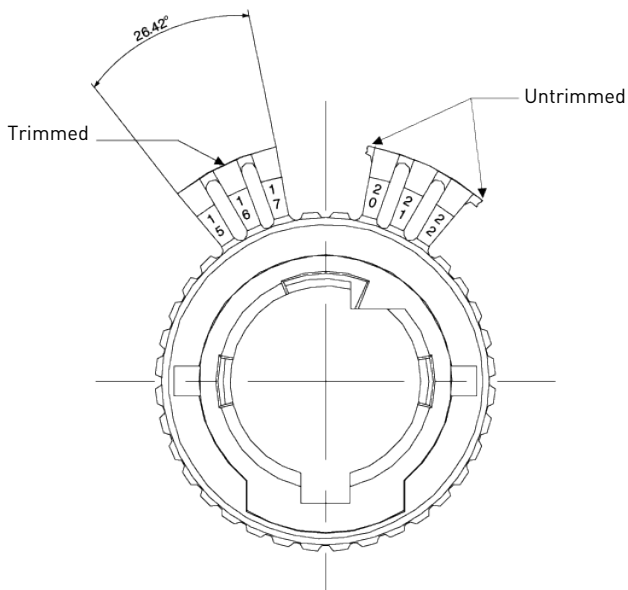

## 3.7 Softener operating mode

### 3.7.1 298 Valves (5 - Cycle softener)

#### Service (downflow) — cycle C0

Untreated water is directed down through the resin bed and up through the riser tube. The hardness ions attach themselves to the resin and are removed from the raw water being exchanged on the resin beads against sodium ions. The water is conditioned as it passes through the resin bed.

#### Backwash (upflow) — cycle C1

The flow of water is reversed by the valve and directed down the riser tube and up through the resin bed. During the backwash cycle, the bed is expanded and debris are flushed to the drain, while the media bed is remixed.

#### Brine (downflow) — cycle C2

The controller directs water through the brine injector and brine is drawn from the brine tank. The brine is then directed down through the resin bed and up through the riser tube to the drain. The hardness ions are displaced by sodium ions and are sent to the drain. The resin is regenerated during the brine cycle. When the air check valve closes brine drawing finishes, and then the slow rinse phase starts.

#### Fast rinse (downflow) — cycle C5

The controller valve directs water down through the resin bed and up through the riser tube to the drain. Any residual brine is rinsed from the resin bed, while the media bed is re-compacted.

#### Brine refill — cycle C8

Water is directed to the brine tank at a rate controlled by the refill controller, to create brine for the next regeneration. During brine refill, treated water is already available at the valve outlet.

#### Info



**For illustration purpose only. Always verify inlet and outlet marking on the valve.**

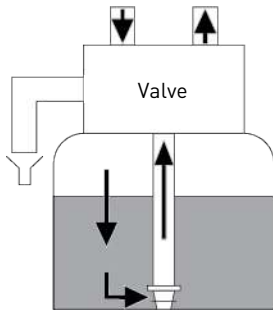

SERVICE  
C0

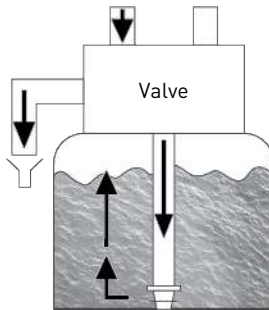

BACKWASH  
C1

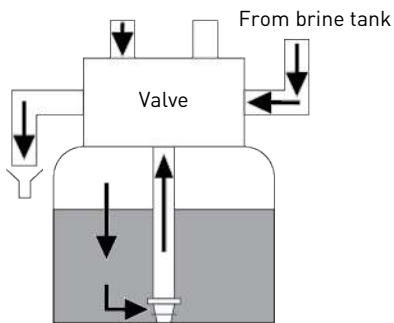

BRINE/SLOW RINSE  
C2 and C3

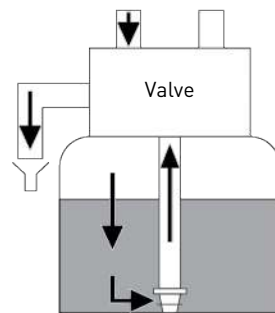

FAST RINSE  
C5

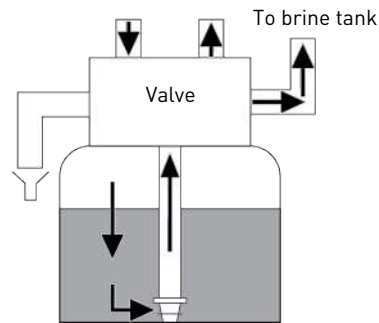

BRINE REFILL  
C8

### 3.7.2 293 Valves (3 - Cycle filter)

#### Service — cycle C0

Untreated water is direct down through the conditioning media and up through the riser tube, then out to the system.

#### Backwash — cycle C1

The flow of water is reversed by the valve and directed down the riser tube and up through the conditioning media. During the backwash cycle, the bed is expanded and debris is flushed to the drain, while the media bed is remixed.

#### Fast rinse — cycle C5

The controller valve directs water down through the media bed and up through the riser tube to the drain. Media bed is re-compacted inside the tank.

**Info**



**For illustration purpose only. Always verify inlet and outlet marking on the valve.**

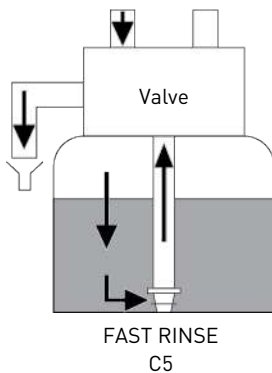
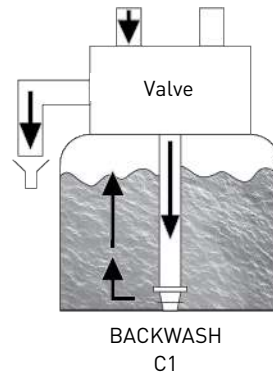
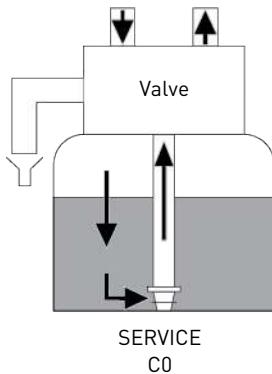

## 4 System sizing

### 4.1 Recommendations

#### 4.1.1 Injector and Refill controller charts

Vessel diameter		Injector flow control		Refill flow control		Backwash flow control	
[In]	[cm]	[gpm]	[m <sup>3</sup> /h]	[gpm]	[m <sup>3</sup> /h]	[gpm]	[m <sup>3</sup> /h]
14	35.6	0.5	0.14	0.7	0.19	5	1.36
16	40.6	0.5	0.14	0.8	0.22	6	1.64
18	45.7	0.6	0.16	1	0.27	8	2.18
21	53.3	0.9	0.25	1.4	0.38	10	2.73
24	61	1.4	0.38	2	0.55	14	3.82
30	76.2	2	0.55	3	0.82	21	5.73
36	91.4	3.3	0.9	5	1.36	30	8.18

#### Info



All flow rates are based on an inlet pressure of 59.9 psi (413 kPa). Actual rates vary with pressure, temperatures and other system variables.

#### 4.1.2 Drain line flow control

Flow control disc		Insert 1	Insert 2	Insert 3	Insert 4
[gpm]	[m <sup>3</sup> /h]				
5	1.135	Blue	Black	Black	Black
6	1.362	Red	Black	Black	Black
7	1.589	Brown	Black	Black	Black
8	1.816	Green	Black	Black	Black
9	2.043	Beige	Black	Black	Black
10	2.27	Blue	Blue	Black	Black
11	2.497	Red	Blue	Black	Black
12	2.724	Red	Red	Black	Black
13	2.951	Brown	Red	Black	Black
14	3.178	Brown	Brown	Black	Black
15	3.405	Blue	Blue	Blue	Black
16	3.632	Green	Green	Black	Black
17	3.859	Beige	Green	Black	Black
18	4.086	Beige	Beige	Black	Black
19	4.313	Beige	Rust	Black	Black
20	4.54	Blue	Blue	Blue	Blue
21	4.767	Brown	Brown	Brown	Black

Flow control disc		Insert 1	Insert 2	Insert 3	Insert 4
[gpm]	[m <sup>3</sup> /h]				
22	4.994	Green	Green	Red	Black
23	5.221	Green	Green	Brown	Black
24	5.448	Red	Red	Red	Red
25	5.675	Green	Green	Beige	Black
26	5.902	Beige	Beige	Green	Black
27	6.129	Beige	Beige	Beige	Black
28	6.356	Brown	Brown	Brown	Brown
29	6.583	Brown	Brown	Brown	Green
30	6.81	Rust	Rust	Rust	Black
31	7.037	Green	Green	Green	Brown
32	7.264	Green	Green	Green	Green
33	7.491	Green	Green	Green	Beige
34	7.718	Green	Green	Green	Rust
35	7.945	Beige	Green	Green	Green
36	8.172	Beige	Beige	Beige	Beige
37	8.399	Beige	Beige	Beige	Rust
38	8.626	Rust	Rust	Rust	Green
39	8.853	Rust	Rust	Rust	Beige
40	9.08	Rust	Rust	Rust	Rust

**Info**



**Drain line flow controls above 40 gpm (9.08 m<sup>3</sup>/h) require external control installed in drain line.**

### 4.1.3 Recommended backwash flow rates for various media

Media	Tank diameter						
	14"	16"	18"	21"	24"	30"	36"
	(35.6 cm) Tank	(40.6 cm) Tank	(45.7 cm) Tank	(53.3 cm) Tank	(61.0 cm) Tank	(76.2 cm) Tank	(91.4 cm) Tank
* Softening Resin (5.0 gpm/ft <sup>2</sup> ) (12.25 m/h/cm <sup>2</sup> )	5	7	9	12	15	25	35
* Fine Mesh Softening resin (2.8 gpm/ft <sup>2</sup> ) (6.86 m/h/cm <sup>2</sup> )	3	4	5	7	9	14	20
Multi Layer (15 gpm/ft <sup>2</sup> ) (36.75 m/h/cm <sup>2</sup> )	15	20	25	36	50	70	105
Birm, Greensand, Carbon (10 gpm/ft <sup>2</sup> ) (24.5 m/h/cm <sup>2</sup> )	10	15	17	25	30	50	70

\* 50°F (10°C) water temperature, 50% bed expansion.

### 4.2 Cycle time calculation

All the Logix controller range automatically calculates the unit capacity as well as the cycle time. No calculations are therefore required.

### 4.3 Injector flow rates

The following graphs represent the injectors flow rate as a function of the inlet pressure for the different injector sizes.

TOTAL
BRINE DRAW
RINSE

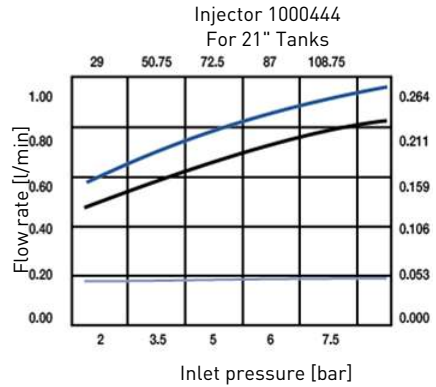
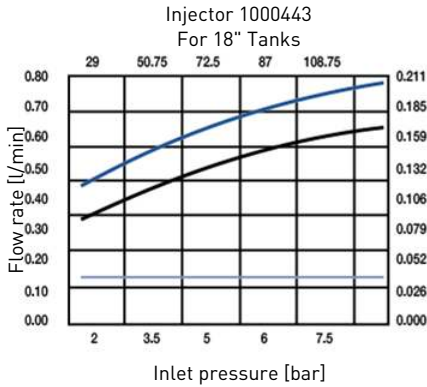
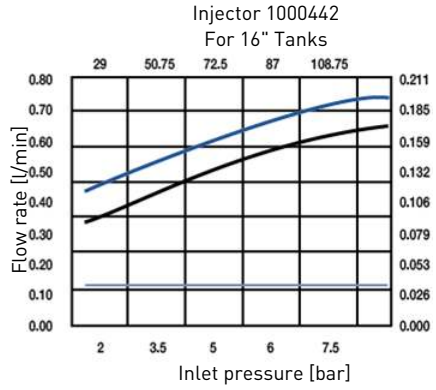
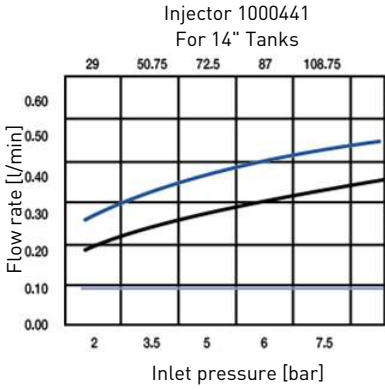

— **BRINE DRAW**  
— **TOTAL**      — **RINSE**

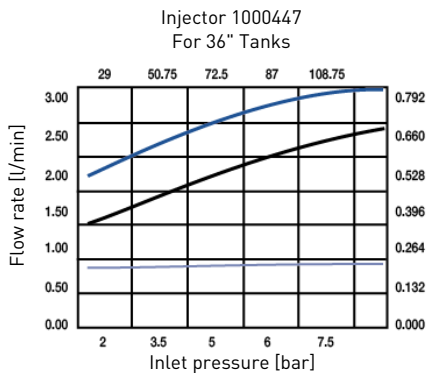
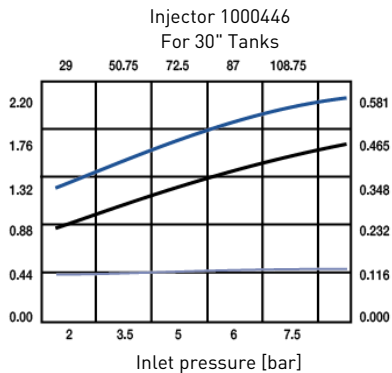
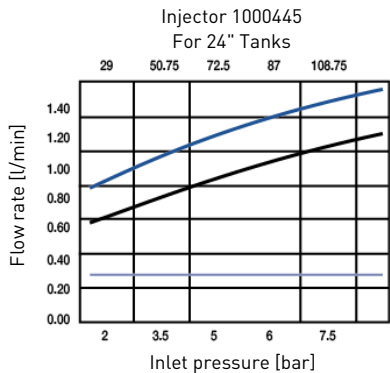

## 4.4 Standard efficiency exchange capacity

Salt amount [g/l <sub>resin</sub> ]	Corresponding resin exchange capacity [g/l <sub>resin</sub> ] as CaCO <sub>3</sub>	°f.m <sup>3</sup> [per l <sub>resin</sub> ]	°dH.m <sup>3</sup> [per l <sub>resin</sub> ]
50	29.9	2	1.67
60	34	2.4	1.9
70	37.5	2.81	2.09
80	40.6	3.21	2.27
90	43.4	3.61	2.42
100	45.9	4	2.56
110	48.2	4.41	2.69
120	50.2	4.81	2.8
130	52.1	5.21	2.91
140	53.8	5.38	3.01
150	55.5	5.55	3.1
170	58.5	5.85	3.27
200	62.7	6.27	3.5
230	66.9	6.69	3.74
260	71	7.1	3.97
290	75.3	7.53	4.21

## 5 Installation

### CAUTION



#### **Risk of injury due to electrical shock or pressurized elements !**

It is strictly forbidden for not qualified personal, to accede to system's internal parts to perform any kind of technical action.

Be sure to disconnect the electrical power, close the water inlet and depressurize the system before opening the front cover to access internal parts !

### 5.1 Product identification

#### Info



**The Magnum 293-298 Logix 764 product is sold in several configurations; It is important to identify your configuration before proceeding with installing the product.**

First check whether the product is already equipped with a power supply or not; if it is not present, the product must be powered with the following characteristics:

Output current frequency	50/60 Hz	Minimum power absorption	8 W
Output current voltage	12 VAC	Insulation Class	II
Connector Type	O.D. 5.5 mm x I.D. 2.1 mm [7/32" x 1/12"]		

The input characteristics of the power supply depend on the electrical network available on site.

### DANGER



**The choice of a correct power supply is mandatory to guarantee the safety of users, if you do not feel expert, consult a professional.**

The power supplies that Pentair supplies with the product are different and can be recognized by the part number on the power supply data plate; and these are:

Part number	Type	Plug type	Input electrical rating
1000814	European Transformer	Type C	230 VAC; 50/60 Hz
1000813	UK Transformer	Type G	230-240 VAC; 50/60 Hz
1000810	Japanese Transformer	Type A	100 VAC; 50/60 Hz
1000812	Australian Transformer	Type I	240 VAC; 50/60 Hz
44149	Noth American Transformer	Type A	120 VAC; 50/60 Hz
44156	Outdoor North American Transformer	Type B	120 VAC; 50/60 Hz

#### Mandatory



**Always check first if the supplied transformer is compatible with the local electrical network!**

### 5.2 Safety notices for installation

- Observe all warnings that appear in this manual;

- only qualified and professional personnel are authorized to carry out installation work.

## 5.3 Installation environment

### 5.3.1 General

- Use only regenerant salts designed for water softening. Do not use ice melt, block, or rock salts;
- keep the media tank in an upright position. Do not turn on its side, upside down, or drop it. Turning the tank upside down may cause media to enter the valve or might clog the upper screen;
- follow State and local codes for water testing. Do not use water that is micro-biologically unsafe or of unknown quality;
- when filling the media tank with water, first place the valve in the backwash position, then partly open the manual valve. Fill the tank slowly to prevent media from exiting the tank;
- when installing the water connection (bypass or manifold), first connect to the plumbing system. Allow heated parts to cool and cemented parts to set before installing any plastic parts. Do not get primer or solvent on O-rings, nuts, or the valve;
- a minimum dynamic operating water pressure of 25 psi (172 kPa) is required for the Magnum control valve to operate properly.

### 5.3.2 Water

#### CAUTION



**Do not treat water under 33.8°F (1°C) or over 100.4°F (38°C), hot water would damage the softener and void warranty.**

- If you are on a private well system, check minimum water pressure with an accurate gauge (gauges on older water systems are often inaccurate). Static pressure that is less than 29 psi (2 bar) may cause low flow rate and inadequate regeneration, depending by the pressure drop of the system as a minimum of 20 psi (1.38 bar) dynamic pressure is required for the valve's injector to operate effectively.

#### Mandatory



**Do not exceed a maximum of 121 psi (8.6 bar) inlet pressure. Should this happen or be subject to happen, it is necessary to install a pressure regulator upstream the system.**

### 5.3.3 Electrical

There are no user-serviceable parts in the AC/AC or AC/DC transformer, motor, or controller. In the event of a failure, these should be replaced.

- all electrical connections must be completed according to local codes;
- use only the power AC/AC or AC/DC transformer that is supplied;

#### Mandatory



**The use of any power transformer other than the one supplied void the warranty of all electronic parts of the valve!**

- to disconnect power, unplug the AC/AC or AC/DC transformer from its power source;
- an uninterrupted current supply is required. Please make sure that the voltage supply is compatible with the unit before installation;
- make sure the controller power source is plugged in;
- if the electrical cable is damaged, it is imperative that it is replaced by qualified personnel.

### 5.3.4 Mechanical

#### Caution - material



#### Risk of damage due to wrong lubricant use

Do not use petroleum-based lubricants such as Vaseline, oils, or hydrocarbon-based lubricants.

Use only approved silicone grease or soapy water!

- all plastic connections should be hand-tightened. PTFE (plumber's tape) may be used on connections that do not use an O-ring seal. Do not use pliers or pipe wrenches;
- existing plumbing should be in a good shape and free from limescale. In case of doubt, it is preferable to replace it;
- all plumbing must be completed according to local codes and installed without tension or bending stresses;
- soldering near the drain line should be done before connecting the drain line to the valve. Excessive heat will cause interior damage to the valve;
- do not use lead-based solder for sweat solder connections;
- the drain line may be elevated up to 70.87" (1.8 m) providing the run does not exceed 181.1" (4.6 m) and water pressure at the softener is not less than 40 psi (2.76 bar). Elevation can increase by 24.01" (61 cm) for each additional 10 psi (0.69 bar) of water pressure at the drain connector;
- to prevent mineral loss during backwash and to ensure proper operation of the valve, a drain line flow control must be plumbed into the drain line prior to placing the valve in service mode. Flow controls from 5 to 40 gpm (18.92 to 151.4 L/min) can be easily installed in the drain line. Flow controls greater than 40 gpm (151.4 L/min) must be plumbed externally. The selection of the proper drain line flow control depends on the tank size and media used for the installation;
- the drain line must be a minimum of 1/2" (12.7 mm) in diameter. Use 3/4" (19 mm) pipe if the backwash flow rate is greater than 7 gpm (26.5 L/min) or the pipe length is greater than 236.2" (6 m);
- do not support the weight of the system on the control valve fittings, plumbing, or the bypass;
- it is not recommended to use sealants on the threads. Use PTFE (plumber's tape) on the threads of the 1" (25.4 mm) NPT elbow, the drain line connections, and other NPT/BSP threads.

### 5.3.5 Outdoor Locations

When the water softening system is installed outdoors, several points must be considered:

- power supply - only products with an outdoor power supply can be installed outdoors;

- moisture — The valve and Logix 764 controller are rated for IP23 locations. Falling water should not affect performance. The system is not designed to withstand extreme humidity or water spray from below. Examples are: constant heavy mist, near corrosive environment, upwards spray from sprinkler;
- direct sunlight — The materials used will fade or discolour over time in direct sunlight. The integrity of the materials will not degrade to cause system failures. If it is necessary to locate the softener in direct sunlight, a protective outdoor cover over the valve and controller is necessary;
- temperature — Extreme hot or cold temperatures may cause damage to the valve or controller. Freezing temperatures will freeze the water in the valve. This will cause physical damage to the internal parts as well as the plumbing. High temperatures will affect the controller. The display may become unreadable but the controller should continue to function. When the temperature drops back into normal operating limits the display will return to normal. A protective cover should assist with high temperature applications;
- insects — The controller and valve have been designed to prevent all but the smallest insects from entering critical areas. All holes in the top plate can be covered with a sheet of duct tape. The top cover must be installed securely in place.;
- wind — The Logix 764 cover is designed to withstand a 30 mi/h (48 km/h) wind when properly installed on the valve.

## 5.4 Integration constraints

Location of a water treatment system is important. The following conditions are required.

### CAUTION



**The surface for installation (platform or floor) must be solid, flat and level.**

### Mandatory



**Drain must be capable of handling a backwash flow rate of 5 gpm (19 l/min).**

- locate the softener as close as possible from drain discharge point and within 40 ft (12.2 m) maximum of drain discharge point, respecting minimum drain line diameter advises given at chapter Drain line connection [→Page 45];
- room to access equipment for maintenance and adding brine (salt) to tank;
- constant electrical supply to operate the controller;
- total minimum pipe run to water heater of 9.8 ft (3 m) to prevent backup of HW into system;
- always install check valve before water heater to protect the softener from HW return;
- local drain for discharge as close as possible;
- water line connections with shut off or bypass valves;
- must meet any local and state codes for site of installation;
- valve is designed for minor plumbing misalignments. Do not support weight of system on the plumbing;
- use flexible piping to connect main piping to softener;

- be sure all soldered pipes are fully cooled before attaching plastic valve to the plumbing.

## 5.5 Block diagram and configuration example

### Block diagram

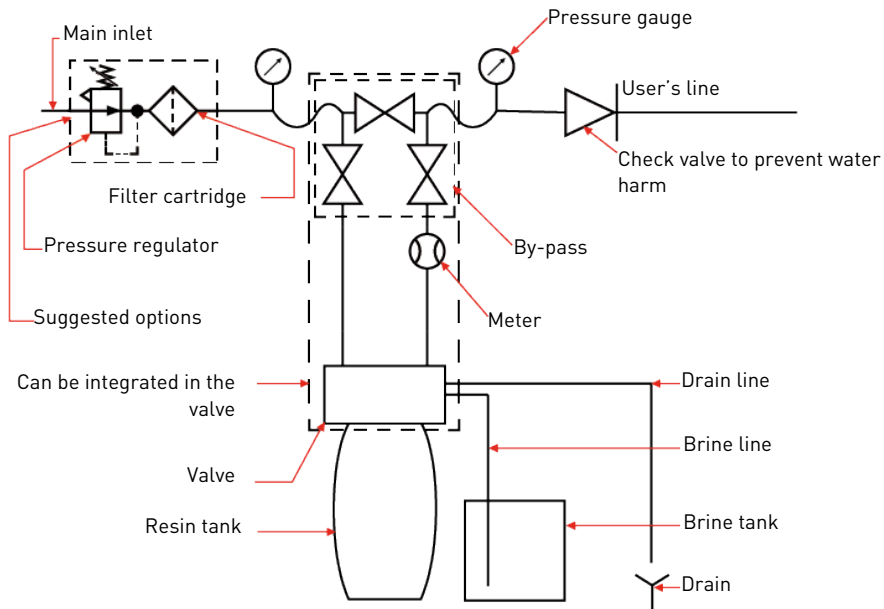

### Configuration description

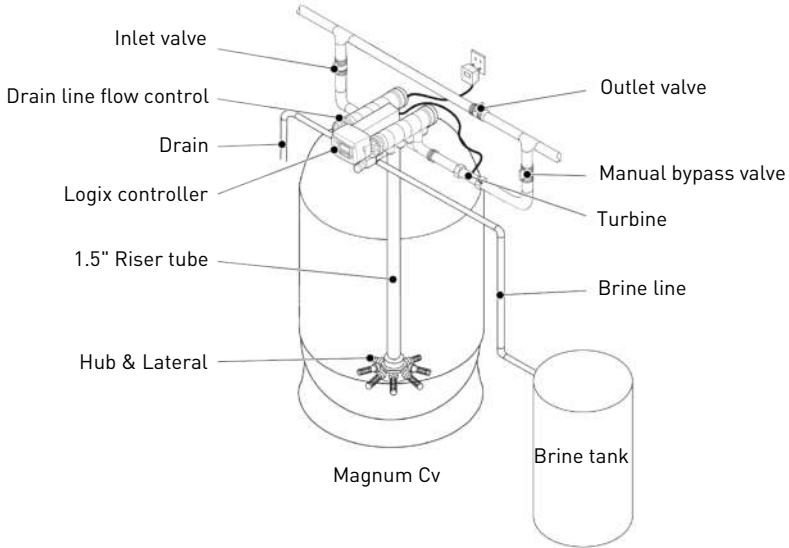

### Configuration example

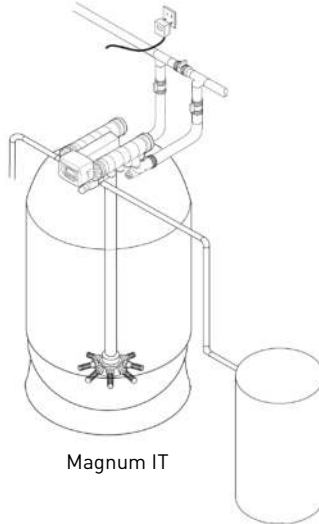

**Typical Installation Drawings**

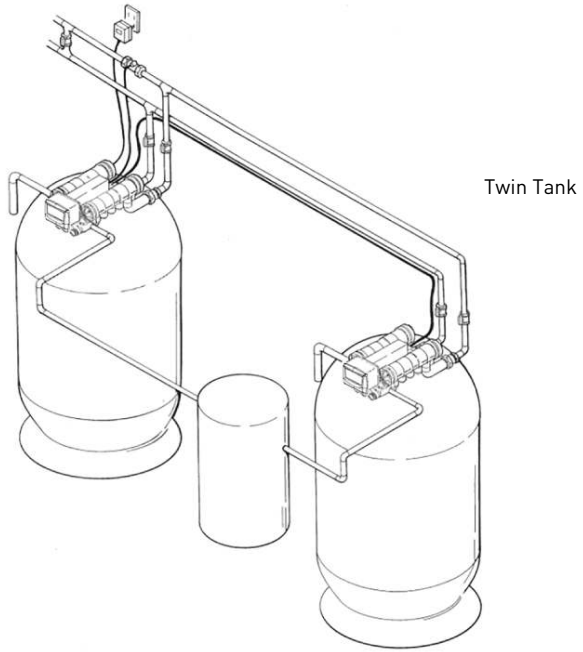

**Typical Installation Drawings**

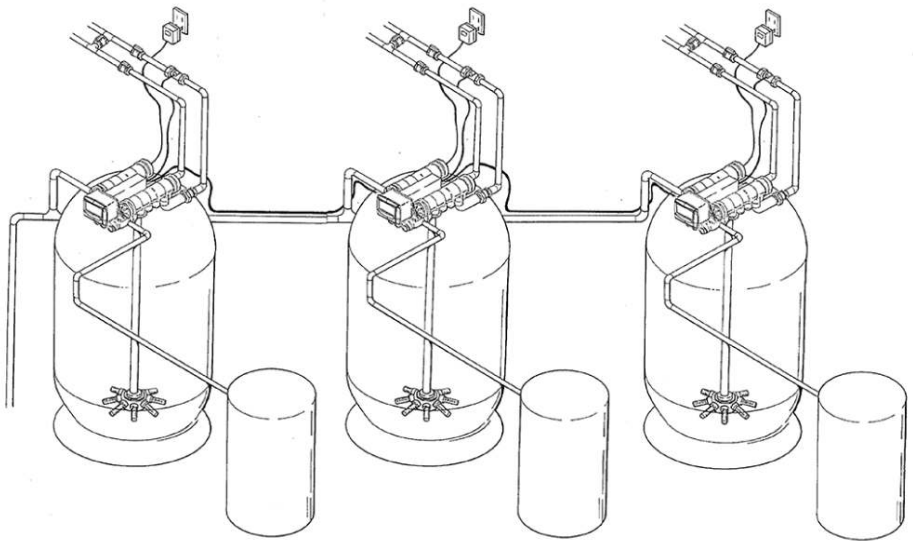

Multiple Tank

## 5.6 Valve on tank assembly

1. Lubricate the seals with approved silicone grease.
2. Spin the valve (1) onto the tank (2), ensuring the threads are not cross-threaded.
3. Rotate the valve (1) clockwise and freely, without using force until it comes to a stop.

### Info



This stop position is considered point zero.

4. Rotate the valve (1) clockwise from point zero to between  $\frac{1}{4}$  turn and  $\frac{1}{2}$  turn.

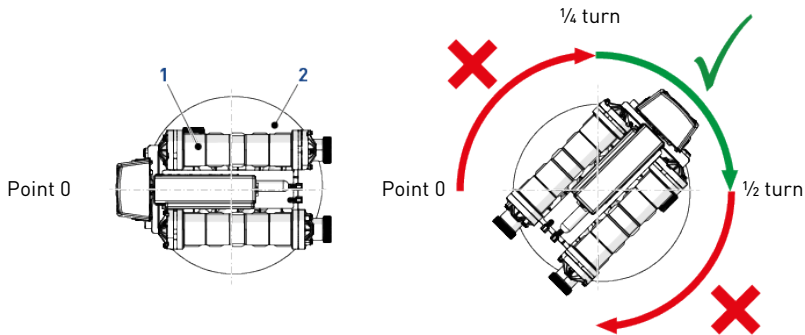

## 5.7 Valve connection to piping

The connections should be hand tightened using PTFE (plumber's tape) on the threads if using the threaded connection type.

In case of heat welding (metal type connection), the connections should not be made to the valve when soldering.

### Tip



See chapter Components description and location [→Page 17] to identify the connections.

When pressurized, any composite tank will expand both vertically and circumferential. In order to compensate the vertical expansion, the piping connections to the valve must be flexible enough to avoid overstress on the valve and tank.

### 5.7.1 Top-mounted valve installation

The valve and tank should not be supporting any part of the piping weight. This is hence compulsory to have the piping fixed to a rigid structure (e.g. frame, skid, wall, etc.) so that the weight of it is not applying any stress on the valve and tank.

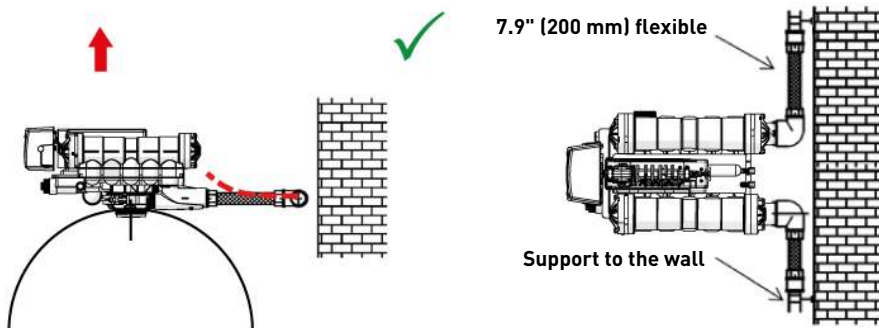

- The diagrams above illustrate how the flexible piping connection should be mounted;
- in order to adequately compensate the tank elongation, the flexible tubes must be installed **horizontally**;
- should the flexible piping connection be installed in vertical position, instead of compensating the elongation, it will create additional stresses on the valve & tank assembly. Therefore, this is to be avoided;
- the flexible piping connection must also be installed stretched, avoiding excessive length. For instance, 7.9" to 15.8" (20 to 40 cm) is enough;
- excessively long and non-stretched flexible piping connection will create stresses on the valve and tank assembly when the system is pressurized, as illustrated in the below picture: on the left the assembly when the system is unpressurized, on the right the flexible piping connection when put under pressure tends to lift up the valve when stretching up. This configuration is even more dramatic when using semi-flexible piping;
- failure to provide enough vertical compensation may lead to different kinds of damage, either on the valve thread which is connected to the tank, or on the female thread connection of the tank. In some cases, damage may also be seen on the valve inlet and outlet connections;

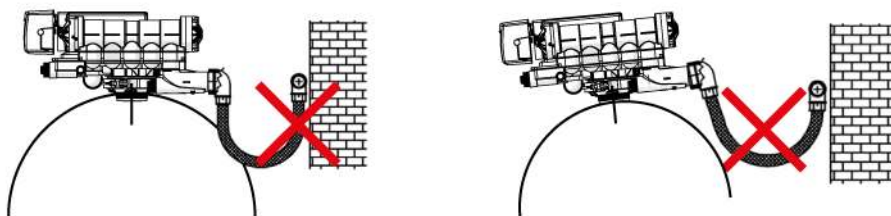

- in any case, any failure caused by improper installations and/or piping connections may void the warranty of Pentair products;
- in the same way, using lubricant\* on the valve thread is not allowed and will void the warranty for the valve and tank. Indeed, using lubricant there will cause the valve to be over-torqued, which may lead to valve thread or tank thread damage even if the connection to piping has been done following the above procedure.

\*Note: do not use petroleum or hydrocarbon-based lubricants. Using these types of lubricants will structurally damage valve and cause failures. Use only 100 % silicone lubricants.

## 5.7.2 Side-mounted valve installation

Use a 2" BSP side mount adapter assembly for the installation.

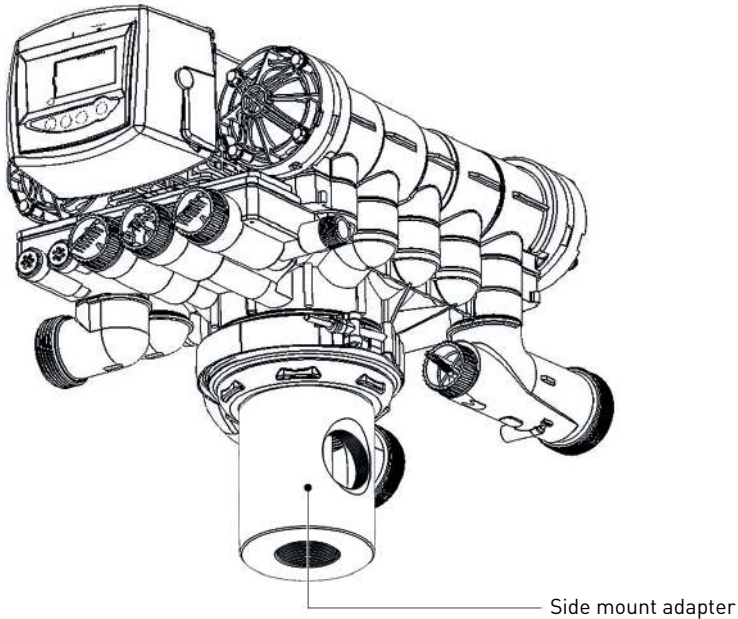

- valid for location having a reduced height;
- to avoid the piping supporting the valve and side adapter weight, they must be fixed on a tripod or any other appropriate support;
- in order to adequately compensate the tank elongation, the rubber expansion joints must be mounted on the top and bottom of the tank.

### Caution - material



**Respect the heights given by the manufacturer.**

## 5.8 Connections (electrical)

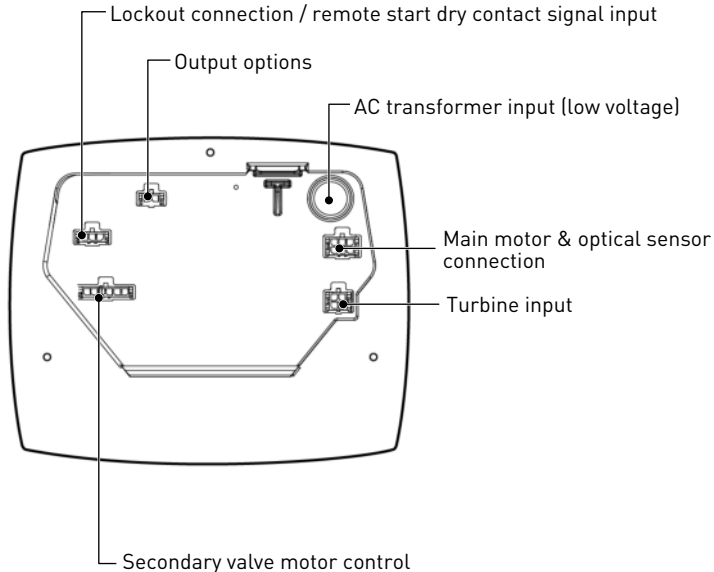

### 5.8.1 Wiring diagrams

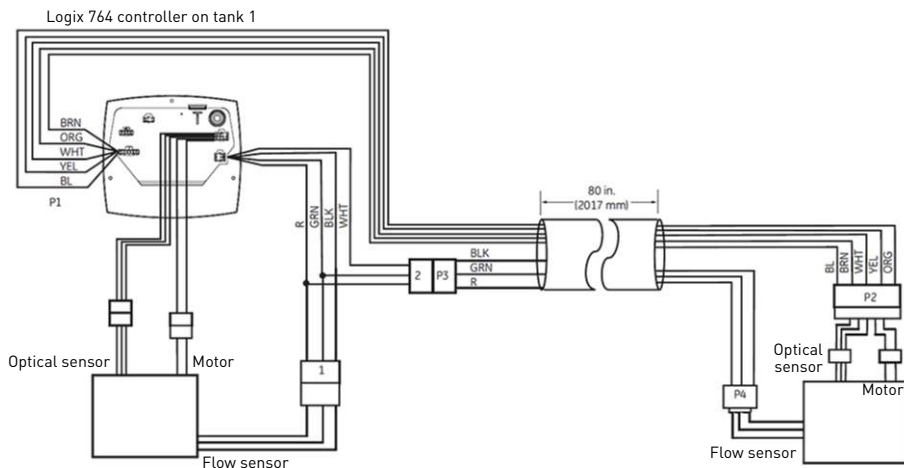

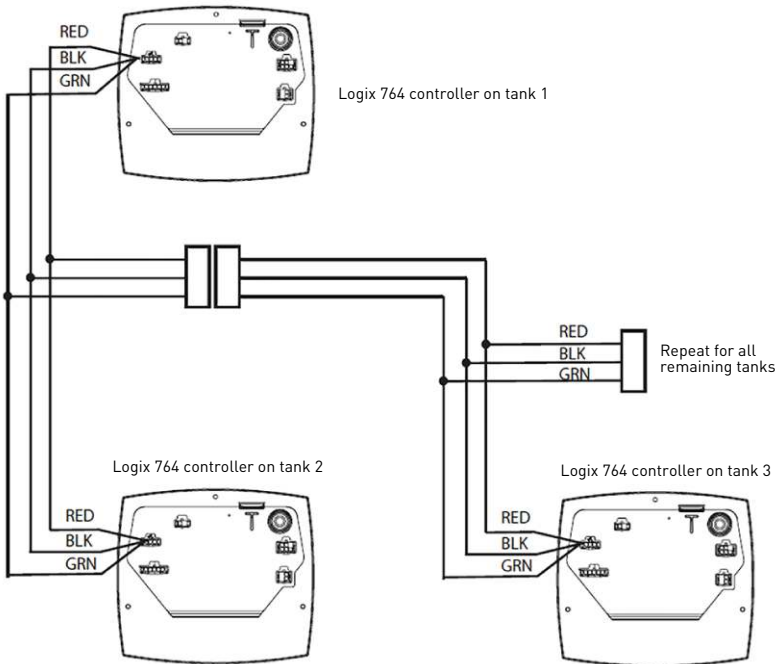
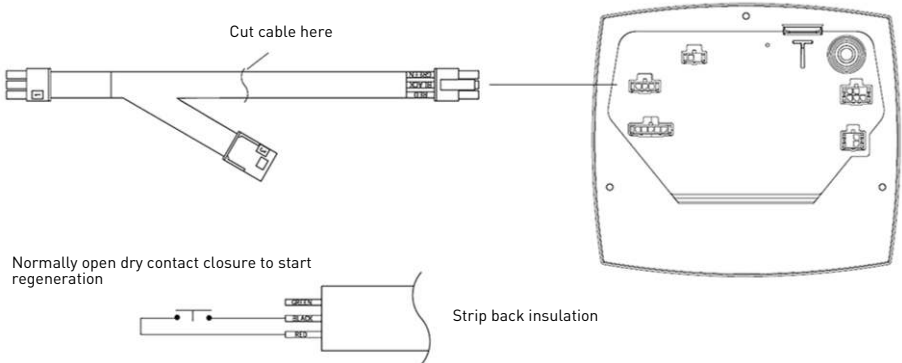

## 5.9 Bypassing

A bypass valve system should be installed on all water conditioning systems. Bypass valves isolate the softener from the water system and allow unconditioned water to be used and also maintains the continuity of the water supply when the product is disconnected. Service or routine maintenance procedures may also require that the system is bypassed.

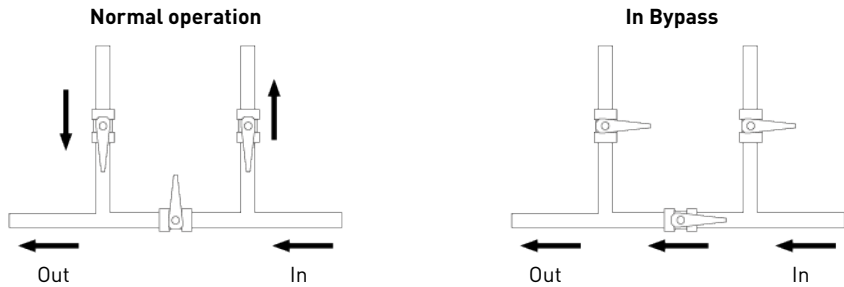
**Caution - material**

**Risk of damage due to bad mounting!**

Do not solder pipes with lead-based solder.

Do not use tools to tighten plastic fittings. Over time, stress may break the connections. When the bypass valve is used, only hand tighten the plastic nuts.

Do not use petroleum grease on gaskets when connecting bypass plumbing. Use only 100% silicone grease products when installing any plastic valve. Non-silicone grease may cause plastic components to fail over time.

## 5.10 Drain line connection

**Info**

**Standard commercial practices are expressed here.**

Local codes may require changes to the following suggestions.

Check with local authorities before installing a system.

**Mandatory**

**The drain line must be built with 1½" rigid piping! An air gap must be present at the drain!**

**CAUTION**

**Risk of injury due to whipping hose!**

Flexible and semi-flexible hoses may bend and whip during draining.

The drain line may be elevated up to 70.9" (1.8 m) provided the run does not exceed 181.1" (4.6 m) and water pressure at the softener is not less than 40 psi (2.76 bar) (0.3 Mpa). Elevation can increase by 24" (61 cm) for each additional 10 psi (0.69 bar) (0.1 Mpa) of water pressure at the drain connector.

Where the drain empties into an overhead sewer line, a sink-type trap must be used.

Secure the end of the drain line to prevent it from moving.

**Mandatory**

**Waste connections or the drain outlet shall be designed and constructed to provide connection to the sanitary waste system through an air-gap of 2 pipe diameters or 3" (76.2 mm), whichever is larger.**

**Caution - material**

**Risk of damage due to lack of gap!**

Never insert the drain line directly into a drain, sewer line or trap. Always allow an air gap between the drain line and the waste water to prevent the possibility of sewage being back-siphoned into the softener.

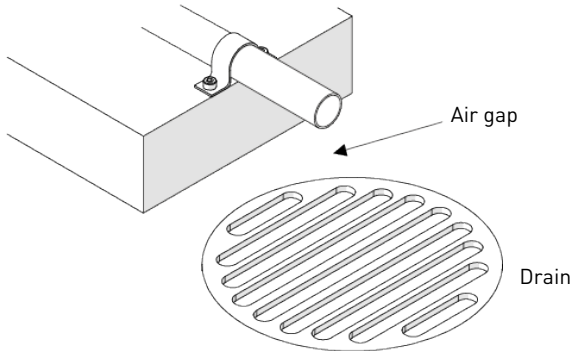

## 5.11 Overflow line connection

In the event of a malfunction, the brine tank overflow fitting will direct "overflow" to the drain instead of spilling on the floor. This fitting should be on the side of the brine tank. Most brine tank manufacturers feature a pre-drilled hole for the tank overflow connector.

To connect the overflow line, locate the hole on the side of the tank. Insert the overflow fitting into the tank and tighten with plastic thumb nut and gasket as shown below. Attach a ½" (12.7 mm) I.D. tubing (not supplied) to fitting and run to drain.

Do not elevate overflow higher than overflow fitting.

Do not tie into the drain line of the controller unit. The overflow line must be a direct, separate line from overflow fitting to drain, sewer or tub. Allow an air gap as per drain line instructions.

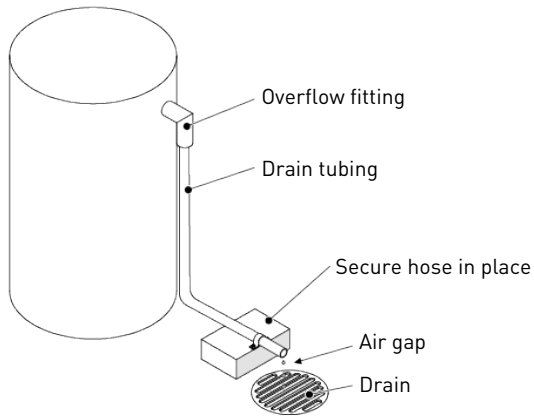

**Caution - material**



**Risk of flooding due to lack of floor drain!**

Floor drain is always recommended to avoid flooding in case of overflow.

## 6 Programming

### 6.1 Display

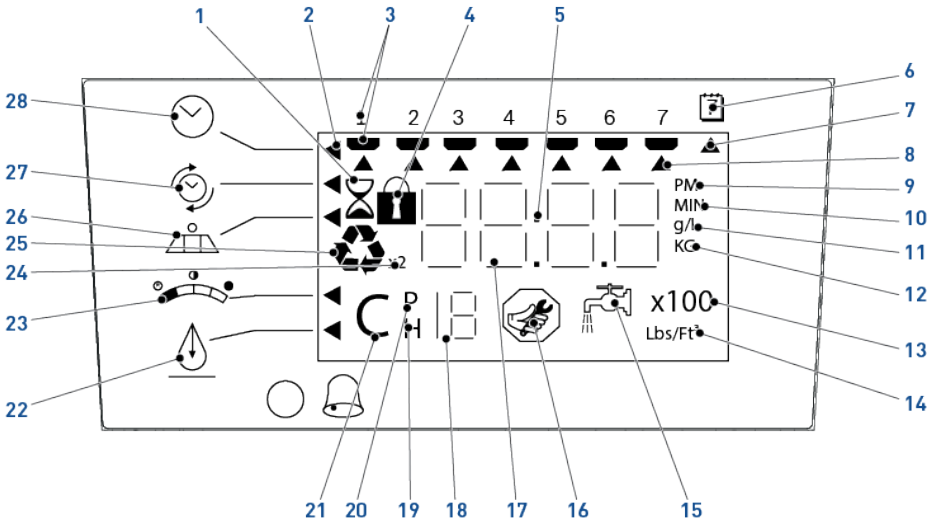



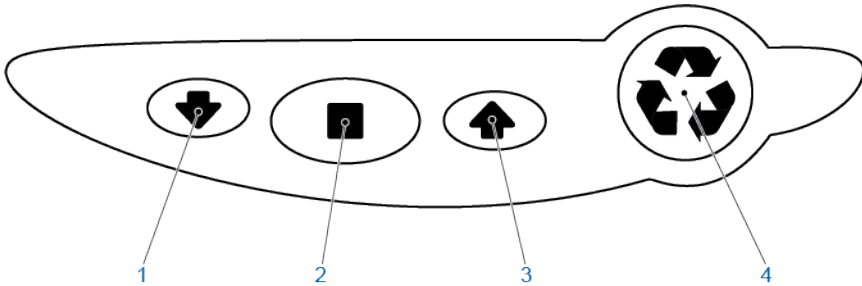

- |    |                           |   |
|----|---------------------------|---|
| 1. | Hourglass                 | Displayed when the motor is running. The camshaft should be turning.  |
| 2. | Cursor                    | These cursors appear next to the item that is currently displayed.  |
| 3. | Days of the week          | Displayed days of the week.   |
| 4. | Locked/unlocked indicator | This symbol is display in basic programming when the current parameter is locked-out.<br><br>It is also used in advanced programming to indicate if the displayed parameter is locked when the controller is in basic programming (the icon flashes). |
| 5. | Colon                     | Colon flashes as part of the time display.  |
| 6. | Indicator                 | Indicator for day regeneration programming.   |
| 7. | Cursor                    | This cursor is displayed when the days between regeneration are being programmed (used with 0.5 to 99 day regeneration programming).  |
| 8. | Cursor                    | One of these cursors is displayed to indicate which day is programmed into the controller.  |
| 9. | "PM"                      | Indicates that the time displayed is between 12:00 noon and 12:00 midnight.<br><br>"PM" indicator is not used if the clock mode is set to 24-hour (there is no AM indicator).   |

10.	"MIN"	Indicates that the value entered/displayed is in minute increments.
11.	"g/L"	Indicates that the value entered/displayed is in grams/Liter.
12.	"KG"	Indicates that the value entered/displayed is in kilograms or kilograins.
13.	"x100"	x100 multiplier for large values.
14.	"Lbs/ft <sup>3</sup> "	Indicates that the value entered/displayed for regenerant amount is in pounds per cubic foot.
15.	Faucet	Appears when the current flow rate is displayed. The controller may show the faucet and "0", indicating no flow.
16.	Maintenance interval	Displayed when the month in service exceed the value programmed in parameter P11.
17.	Digits	Four digits used to display the time, program value or error codes.
18.	Number	Used with #19, #20 and #21. Displays a sequence number or value.
19.	History values (H)	The number displayed by #18 identifies which history value is currently displayed.
20.	Parameter (P)	Displayed only in advanced programming. The number displayed by #18 identifies which parameter is currently displayed.
21.	Cycle (C)	The number displayed by #18 is the current cycle in the regeneration sequence.
22.	Hardness	Hardness setting - not used.
23.	Capacity	Shows estimated system capacity.
24.	"x2"	Indicates a second regeneration has been called for.
25.	Recycle sign	Flashes when a regeneration at the next time of regeneration has been called for. Also displayed (continuously) when in regeneration.
26.	Salt	Programming the amount of regenerant. If the controller is on a 3-cycle filter then the backwash time is displayed.
27.	Regeneration time and day	Programming the time of regeneration and the days of regeneration.
28.	Time and day	Programming the current time and day.

## 6.2 Commands



- |   |   |
|---|---|
| 1.  - Down arrow | Used to scroll down or decrement through a group of choices.  |
| 2.  - Set button | Used to accept a setting that normally becomes stored in memory.<br><br>Also used together with the arrow buttons to access special features. |
| 3.  - Up arrow   | Used to scroll up or increment through a group of choices.  |
| 4.  - Regenerate | Used to command the controller to regenerate.<br><br>Also used to change the lock mode.   |

### 6.2.1 Programming overview

The 764 controller includes multiple program levels that allow the water treatment professional to customize the system for many water conditions. Additionally, historical data can be viewed allowing quick and easy troubleshooting. In most cases level I programming is all that is required to set up the water conditioning system for proper operation. A brief description of each program level is listed below.

Level I : used to program controller for normal applications.

Level II (P-Values) : allows the installer to customize programming for non-standard applications.

Level III (C-Values) : allows the installer to adjust the length of select cycles for non-standard applications.

Level IV History (H-Values) : allows access to historical information for troubleshooting the system.

#### Info







**If a button is not pushed for thirty seconds, the controller returns to normal operation mode.**

## 6.3 Basic programming 764 controller

### 6.3.1 Program valve and system types

Set your valve type through the options.

1. Use  and  to scroll through valve type choices.
  - ⇒ Valve type flashes.
  - ⇒ If this is the first time the controller is powered up, the display will show 255A.
2. Choose the 298 valve type.
3. Press  to validate the system size selected and advance to the next parameter using  or .
4. If an incorrect setting is programmed, see Resetting the controller [→Page 60].

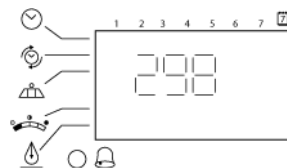

Preprogrammed configurations:

Type	Valve		Application
255A	255	Twin Alternating	8-cycles softener
273A	273		3-cycles filter
278A	278		5-cycles softener
293A	293		3-cycles filter
298A	298		5-cycles softener
255P	255	Twin Parallel	8-cycles softener
273P	273		3-cycles filter
278P	278		5-cycles softener
293P	293		3-cycles filter
298P	298		5-cycles softener
255L	255	Single tank or multi-simplex system (Lockout).	8-cycles softener
263L	263		3-cycles filter
268L	268	Regeneration mode: metered, time clock or remote regeneration	8-cycles softener
273L	273		3-cycles filter
278L	278		5-cycles softener
293L	293		3-cycles filter
298L	298		5-cycles softener

#### Info



**For Timeclock mode programs the controller as a volumetric one, calculate the days the system needs to be in service (day override setting).**

**Remove the water meter cable and/or turbine.**

**Water consumption is not counted, but day override will initiate the regeneration.**

### 6.3.2 Program system size

Set your system in filter configuration.

1. Use and to scroll through resin volume choices.  
⇒ Three dashes than resin volume flashes.
2. Choose the nearest volume to your actual system size.
3. Press to validate the system size selected and advance to the next parameter using or .
4. If an incorrect setting is programmed, see Resetting the controller [→Page 60].

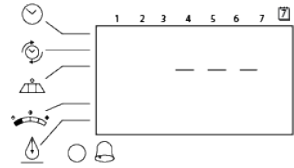

### 6.3.3 Time setting

Set the current time.

1. Press when the time of the day is displayed.  
⇒ Time flashes.
2. Adjust displayed time with and .
3. Press to validate the selection and advance to the next parameter using or .

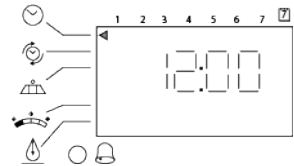

### 6.3.4 Day of week

Set the current day of the week.

1. Press .
- ⇒ Arrow flashes.
2. Select displayed day with and .
3. Press to validate the selection and advance to the next parameter using or .

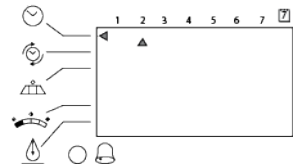

### 6.3.5 Regeneration time

Set the time when regeneration will take place.

1. Press .
- ⇒ Regeneration time flashes.
2. Adjust displayed time with and .
- ⇒ Default setting: 2:00am.
3. Press to validate the selection and advance to the next parameter using or .

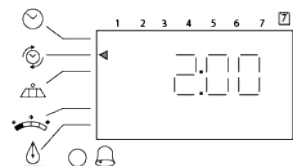

### 6.3.6 Days override

Set the number of days for calendar override.

1. Press **■**.  
⇒ Number of days flashes.
2. Adjust displayed number with **▲** and **▼**.  
⇒ Default time for days override: 0 day (disabled).  
⇒ Days can be adjusted from ½ (0.5) to 99 days.
3. Press **■** to validate the selection and advance to the next parameter using **▼** or **▲**.

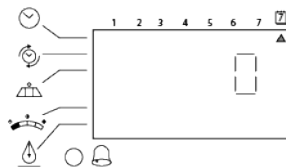

### 6.3.7 Amount of salt used per regeneration

Set desired salt amount in g/L:

1. Press **■**.  
⇒ Salt amount flashes.
2. Adjust displayed settings with **▲** and **▼**.
3. Press **■** to validate the selection and advance to the next parameter using **▼** or **▲**.

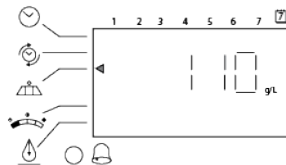

### 6.3.8 Estimated capacity

#### Info



#### Note

The system capacity is displayed in kilograms equivalent  $\text{CaCO}_3$  of hardness removed before a regeneration is necessary.

The system capacity is calculated by the Logix software, using the resin volume and salt dosage.

Set the estimated system capacity on the controller.

1. Press **■**.  
⇒ The amount number flashes.
2. Adjust displayed capacity with **▲** and **▼**.
3. Press **■** to validate the selection and advance to the next parameter using **▼** or **▲**.

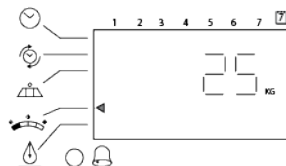

### 6.3.9 Hardness

Set inlet water hardness at installation site.

1. Press **■**.  
⇒ The hardness number flashes.
2. Adjust displayed hardness number with **▲** and **▼**.
3. Press **■** to validate the selection.  
⇒ Initial programming is now complete. The controller will return you to the normal operation mode.

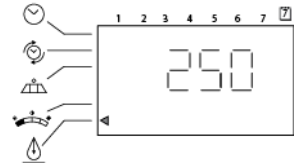

## 6.4 Advanced programming

**Info**



**Press and hold **▲** + **▼** for 5 seconds to access advance programming.**

A "P" symbol is displayed on the bottom left of screen

### 6.4.1 Basic programming parameters (5 - Cycle softener system)

Parameter description	Range of values	Default value	Units of measure	Notes
P1 Time of day	1:00 - 12:59 AM 0:00 - 23:59 PM	12:00 PM	Hour : minute	Range depends on value selected for P10.
P2 Day of week	N/A	None	N/A	-
P3 Time of regeneration	1:00 - 12:59AM 0:00 - 23:59PM	2:00 AM	Hour: minute	Range depends on value selected for P10.
P4 Calendar override	0 - 99	3	Days	0 = no calendar override. 0.5 = regeneration twice a day at time of regeneration and 12 hours later. Calendar override skipped if at least one day of regeneration selected.
P5 Salt setting	50 - 290	110	g/l	Unit of measure depends on value selected for P9.
P6 Capacity of unit	0.1 - 90	*	kg	Unit of measure depends on value selected for P9.

\*Calculated depending on salt setting and resin volume. The capacity may be manually adjusted.

## 6.4.2 Advanced programming parameters (5 - Cycle softener system)

	Parameter description	Range of values	Default value	Units of measure	Notes
P9	Units of measure	0 - 1	**	N/A	0 = US unit. 1 = Metric unit.
P10	Clock mode	0 - 1	**	N/A	0 = 12 hours clock. 1 = 24 hours clock.
P11	Service interval	0 - 250	0	Months	Uses 30 days for each month.
P12	Remote regeneration	3 - 250	0	Months	
P13	Output options	0 - 2	0	N/A	0 = no chlorine generator. 1 = salt check only. 2 = N/A (obs generate chlorine).
P14	Refill rate	1 - 700	*	gpm x 100	-
P15	Draw rate	1 - 700	*	gpm x 100	-
P16	Reserve type	0 - 3	0	N/A	0 = variable reserve delayed regeneration. 1 = fixed reserve delayed regeneration. 2 = variable reserve immediate regeneration. 3 = fixed reserve immediate regeneration.
P17	Initial average or fixed reserve	0 - 70	30	% of capacity	Depends on value selected for P16.
P18	Flow sensor select	0 - 5	*	N/A	0 = internal Magnum NHWB. 1 = 1" Autotrol turbine. 2 = 2" Autotrol turbine. 3 = User defined. K-factor, 4 = User defined pulse equivalent. 5 = internal Magnum HWB.
P19	K-factor or pulse equivalent	1.00 -99.99 0 - 9999	0.01 1	N/A	K-factor P18 = 3. Pulse equivalent P18 = 4.

\* Default value selected with valve type and resin volume.

\*\* Factory default value is "0" for North America and "1" for World units.

### 6.4.3 Basic programming parameters (3 - Cycle filter system)

Parameter description	Range of values	Default value	Units of measure	Notes
P1 Time of day	1:00 - 12:59 AM 0:00 - 23:59 PM	12:00 PM	Hour : minute	Range depends on value selected for P10.
P2 Day of week	N/A	None	N/A	-
P3 Time of regeneration	1:00 - 12:59AM 0:00 - 23:59PM	2:00 AM	Hour : minute	Range depends on value selected for P10.
P4 Calendar override	0 - 99	3	Days	0 = no calendar override. 0.5 = regeneration twice a day at time of regeneration and 12 hours later. Calendar override skipped if at least one day of regeneration selected.
P5 Day of week regeneration	N/A	None	N/A	
P6 Backwash time	1 - 250	14	Minutes	-
P7 Capacity of unit	1 - 900	*	m <sup>3</sup>	Unit of measure depends on value selected for P9.
P8 -	-	-	-	Skipped for 3 - cycle filter configuration.

\* Default value selected with valve type and resin volume.

### 6.4.4 Advanced programming parameters (3 - Cycle filter system)

Parameter description	Range of values	Default value	Units of measure	Notes
P9 Units of measure	0 - 1	**	N/A	0 = US unit. 1 = Metric unit.
P10 Clock mode	0 - 1	**	N/A	0 = 12 hours clock. 1 = 24 hours clock.
P11 Service interval	0 - 250	0	Month	Uses 30 days for each month.
P12 Remote regeneration	3 - 250	60	Second	
P13 -	-	-	-	Skipped for 3 - cycle filter configuration.

Parameter description	Range of values	Default value	Units of measure	Notes	
P14	-	-	-	Skipped for 3 - cycle filter configuration.	
P15	-	-	-	Skipped for 3 - cycle filter configuration.	
P16	Reserve type	0 - 3	0	N/A	0 = variable reserve delayed regeneration. 1 = fixed reserve delayed regeneration. 2 = variable reserve immediate regeneration. 3 = fixed reserve immediate regeneration.
P17	Initial average or fixed reserve	0 - 70	30	% of capacity	Depends on value selected for P16.
P18	Flow sensor select	0 - 5	*	N/A	0 = internal Magnum NHWB. 1 = 1" Autotrol turbine. 2 = 2" Autotrol turbine. 3 = User defined. K-factor, 4 = User defined pulse equivalent. 5 = internal Magnum HWB.
P19	K-factor or pulse equivalent	1.00 -99.99 0 - 9999	0.01 1	N/A	K-factor P18 = 3. Pulse equivalent P18 = 4.

\* Default value selected with valve type and resin volume.

\*\* Factory default value is "0" for North America and "1" for World units.

### 6.4.5 Cycle time programming

Set the cycle time programming.

1. Press and hold the and for 5 seconds when the controller is not in regeneration to enter cycle time programming.
  - ⇒ A small "C#" with a number will be displayed indicating the controller is in cycle time programming.
  - ⇒ The number indicates the cycle being viewed or changed.
  - ⇒ Cycle times are programmable from 0 to 200 minutes.
2. Press .
3. Adjust displayed time with and .
4. Press to validate the selection
  - ⇒ The next cycle time is displayed.

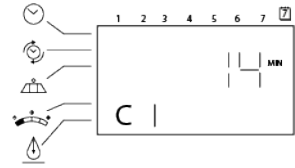

**Info**



**The draw and refill cycle times (C2 & C8) cannot be changed in cycle time programming for 5 - cycle softener system.**

They are calculated using the draw and refill rates and the salt amounts.

Magnum valves 293/298		
Description	Default value [min]	C# displayed
Backwash	14	1
Draw <sup>(1)</sup>	(3)	2 <sup>(2)</sup>
Slow rinse	(4)	3 <sup>(2)</sup>
Fast rinse	6	5
Refill <sup>(1)</sup>	(5)	8

<sup>(1)</sup> Can only be programmed in 3 - cycle filter configuration.



<sup>(2)</sup> Separate draw and rinse positions are present on Magnum cam. The controller stays in the brine draw position for both draw and rinse times then it proceeds through the rinse position with no dwell time. □

<sup>(3)</sup> Depends on valve type and resin volume. Time is calculated from total salt amount and draw rate.

<sup>(4)</sup> Depends on valve type, resin volume and rinse rate. Time is calculated for two bed volume on 298 valves.

<sup>(5)</sup> Depends on valve type and resin volume. Time is calculated from total salt amount and refill rate.

## 6.4.6 Diagnostic

To access diagnostic values, press and hold  and  for 5 seconds, diagnostic H symbol is displayed on the bottom left of the screen.

Diagnostic Code	Description	Unit	Range	764
H0	Initial setting value	Litre	Resin Volume	Yes
H1	Day since last regeneration	N/A	0 - 255	
H2	Current flow rate	Depends on turbine used		
H3	Water used today since time of regeneration	m <sup>3</sup>	0 - 1310.70	
H4	Water used since last regeneration	m <sup>3</sup>	0 - 1310.70	
H5	Total water used since reset in 100 s	m <sup>3</sup>	0-9999	
H6	Total water used since reset in 1000000 s	m <sup>3</sup>	4264 x 10 <sup>4</sup>	
H7	Average usage for Sunday	m <sup>3</sup>	0 - 1310.70	
H8	Average usage for Monday	m <sup>3</sup>	0 - 1310.70	
H9	Average usage for Tuesday	m <sup>3</sup>	0 - 1310.70	
H10	Average usage for Wednesday	m <sup>3</sup>	0 - 1310.70	
H11	Average usage for Thursday	m <sup>3</sup>	0 - 1310.70	
H12	Average usage for Friday	m <sup>3</sup>	0 - 1310.70	
H13	Average usage for Saturday	m <sup>3</sup>	0 - 1310.70	
H14	Average service cycle	Day	0 - 255	
H15	Peak flow rate	l/min	0 - 1000	
H16	Day and time of peak flow rate	Time and day that peak flow occurred		
H17	Months since service	Month	0 - 2184	
H18	Water used since last regeneration - tank 1	m <sup>3</sup>	0 - 1310.70	
H19	Water used since last regeneration - tank 2	m <sup>3</sup>	0 - 1310.70	
Hr	Number of regenerations since last service	N/A	0 - 65536	

## 6.4.7 Resetting the controller

### Info



**Resetting the controller will delete all information stored in its memory, except the time and day.**

This will require you to reprogram the controller completely from the initial power-up mode.

Resetting the controller:

1. To reset the controller, press and hold  for 5 seconds.
  - ⇒ The controller will be reset to an unprogrammed state.
2. Go to Programming [[⇒Page 48](#)], to reprogram the controller.

## 7 Commissioning

### Info



This chapter is available for standard regeneration flows. Contact your supplier if the actual regeneration is not standard and if you need assistance.

### 7.1 Water filling, draining and watertightness inspection

#### 7.1.1 System started

Once you have performed the previous initial programming steps, you will need to activate the softener.



#### Caution - material



**Do not rotate the camshaft by hand or damage to the unit may occur.**

Use the controller to take the camshaft electronically through the cycles

Follow these steps carefully:

1. Remove the cover from the valve. Removing the cover will allow you to see that the camshaft is turning, and in which cycle the camshaft is currently positioned.
2. With the supply water for the system still turned off, position the bypass valve to the "nonbypass" (normal operation) position.
3. Press  on the controller for 5 seconds. This will initiate a manual regeneration.
  - ⇒ The controller will indicate that the motor is turning the camshaft to cycle C1 (Backwash) position by flashing an hourglass. The controller will display the total regen time remaining. If you press and hold the  button, the controller will indicate the time remaining in the current cycle.
4. Fill the media tank with water.
  - ⇒ While the controller is in cycle C1 (Backwash), open the water supply valve very slowly to approximately the ¼ open position.

#### CAUTION



**If opened too rapidly or too far, media may be lost out of the tank into the valve or the plumbing.**



In the ¼ open position, you should hear air slowly escaping from the valve drain line.

- ⇒ When all of the air has been purged from the media tank (water begins to flow steadily from the drain line), open the main supply valve all of the way. This will purge the final air from the tank.
  - ⇒ Allow water to drain out until the water runs clear from the drain line. This purges any refuse from the media bed.
  - ⇒ Turn off the water supply and let the system stand for about 5 minutes. This will allow any trapped air to escape from the tank.
5. Add water to the brine tank (initial fill) (softener only).

- ⇒ With a bucket or hose, add approximately 4 gallons (15 liters) of water to the brine tank. If the tank has a salt platform in the bottom of the tank, add water until the water level is approximately 1" (25 mm) above the platform.

**Info****Note**

We recommend that you do not put salt into the tank before the control valve has been started up. With no salt in the tank, it is much easier to view water flow and motion.

6. Engage the refill cycle to prime the line between the brine tank and the valve (softener only).
  - ⇒ Slowly open the main water supply valve again, to the fully open position. Be sure not to open too rapidly as that would push the media out of the media tank.
  - ⇒ Advance the controller to the Refill (C8) position. From cycle C1 (Backwash), press and hold . This will display the current cycle. While pressing , press  to advance to the next cycle. Continue to advance through each cycle until you have reached cycle C8 (Refill).





**Info****Note**



As you advance through each cycle there will be a slight delay before you can advance to the next cycle. The hourglass icon will be lit while the camshaft is indexing. There may be a pause at cycle C4 (System Pause). This cycle allows the water/air pressure to equalize on each side of the valve discs before moving on. The hourglass will not be visible indicating that the system is paused.

- ⇒ With the water supply completely open, when the valve reaches C8 (Refill), the controller will direct water down through the line to the brine tank. Let the water flow through the line until all air bubbles have been purged from the line.
- ⇒ Do not let the water flow down the line to the tank for more than 1 to 2 minutes, or the tank may overflow.

**Info****Note**

Proceed as previously mentioned taking into account the regeneration sequence described in chapter Regeneration Sequence for Twin and Lockout Systems.

- ⇒ Once the air is purged from the line, press  and  simultaneously to advance to cycle C0 (Treated Water) position.
7. Draw water from the brine tank.
    - ⇒ From the treated water position (cycle C0), advance the valve to the draw brine position. Press  for 5 seconds.
    - ⇒ The controller will begin a manual regen, and advance the control valve to the cycle C1 (Backwash). Press  and  to advance to cycle C2 (Draw).
    - ⇒ With the controller in this position, check to see that the water in the brine tank is being drawn out of the tank. The water level in the tank should recede very slowly.
    - ⇒ Observe the water being drawn from the brine tank for at least 3 minutes. If the water level does not recede, or goes up, check all hose connections. C2 should be displayed.

8. If the water level is receding from the brine tank you can then advance the controller back to the treated water (C0) position by pressing  and  simultaneously to advance the controller to the C0 position.
9. Finally, turn on a faucet plumbed after the water softener. Run the faucet until the water runs clear. Add salt to the brine tank.

### 7.1.2 Additional tips

- When the controller is first plugged in, it may display a flashing hourglass and the message "Err 3", this means that the controller is looking for home position. If the "Err 2" is displayed, check that the incoming power frequency matches the controller;
- with 764 controller programmed in A or P mode "Err.4" may also be displayed on the screen when the controller is looking for secondary valve's home position;
- the preset default time of regeneration is 2:00 AM;
- power supply? The World controller senses the electrical input and decides which is needed;
- the 700 Series controller can be programmed to regenerate on specific days of the week;
- if electrical power is not available, the camshaft can be rotated counter-clockwise by hand if the motor is removed;
- the 700 Series controllers send commands to the motor for camshaft movement. However, water pressure/flow are required during the regeneration cycle for backwash, purge and refill, and brine draw to actually take place;
- make sure the control power source is plugged in. The transformer should be connected to a non-switched power source;
- you can start programming from the beginning by resetting the amount of media, see chapter Resetting the controller [→Page 60].

## 7.2 Sanitization

### 7.2.1 Disinfection of water softeners

The materials of construction of the modern water softener will not support bacterial growth, nor will these materials contaminate a water supply. In addition, during normal use, a softener may become polluted with organic matter, or in some cases with bacteria from the water supply. This may result in an off-taste or odour in the water.

Thus, the softener may need to be disinfected after installation. Some softeners will require periodic disinfection during their normal lifetime. Consult the installing dealer for more information on softener disinfection.

Depending on the conditions of use, the softener type, the type of ion exchanger and the disinfectant available, a choice can be made among the following methods.

### 7.2.2 Sodium or calcium hypochlorite

These materials are satisfactory for use with polystyrene resins, synthetic gel zeolite, greensand and bentonites.

#### 5.25 % Sodium hypochlorite

If stronger solutions are used, such as those sold for commercial laundries, adjust the dosage accordingly.

## **Dosage**

### **Brine tank softeners**

Backwash the softener and add the required amount of hypochlorite solution to the well of the brine tank. The brine tank should have water in it to permit the solution to be carried into the softener.

Proceed with the normal regeneration.

### **Calcium hypochlorite**

Calcium hypochlorite, 70 % available chlorine, is available in several forms including tablets and granules. These solid materials may be used directly without dissolving before use.

Do not let the disinfectant stand for more than 3 hours in the brine tank before the regeneration start.

## **Dosage**

### **Brine tank softeners**

Backwash the softener and add the required amount of hypochlorite to the well of the brine tank. The brine tank should have water in it to permit the chlorine solution to be carried into the softener.

Proceed with the normal regeneration.

## 8 Operation

During a regeneration:

- A "C#" is displayed to show the current cycle;
- total regen time remaining is displayed on screen;
- you can press and hold  to show current cycle time remaining.

### 8.1 Recommendations

- Use only regeneration salts designed for water softening EN 973;
- for optimal system operation, the use of clean salt and impurities free is recommended (for example salt pellets);
- do not use ice melt salt, block, or rock salts;
- the sanitizing process may introduce chlorine compounds which may reduce the life of the ion exchange resins. Refer to media manufacturer specifications sheet for more information.

### 8.2 Manual regeneration

#### Mandatory



**The controller must be in service in order to enable this procedure.**

#### Info







#### Note



The unit returns to normal operation if no buttons are pressed within 30 seconds.

#### Manual delayed regeneration

### 8.3 To advance regeneration cycles

1. Simultaneously press  and  to advance to the next cycle.
  - ⇒ When the camshaft reaches next cycle, "C2" will be displayed.
2. Repeat  and  to advance through each cycle.

### 8.4 To cancel a regeneration

1. Press and hold  and  for 5 seconds to cancel the regen.
  - ⇒ Camshaft will move to service position – may take 1 to 2 minutes.

## 9 Maintenance

### Mandatory



**Cleaning and maintenance shall take place at regular intervals in order to guarantee the proper functioning of the complete system, and be documented in the Maintenance chapter in the User Guide document.**

### Mandatory



**The maintenance and service operation must be done by qualified personnel only.**  
Failure in respecting this may void the warranty.

### Mandatory



**This valve must always be mounted with a DLFC.**

## 9.1 293-298 CV / IT: General system inspection

### Mandatory



**Has to be done once a year at minimum.**

### 9.1.1 Water quality

1. Check for raw water analysis and filter's targeted contaminants concentration.
2. Check for treated water analysis and compare with raw water data.

### 9.1.2 Mechanical checks

1. Inspect general condition of valve and associated ancillaries and check for any leaks, ensure valve connection to piping is made with adequate flexibility as per manufacturer instruction.
2. Inspection of electrical connections, verify wiring connections and search for evidence of overloading.
3. Verify settings of electronic timer, verify regeneration frequency, make sure the valve configuration corresponds to the settings.
4. Check water meter, if present, report water meter settings and compare with previous inspection.
5. Verify total water consumption compared to previous visit.
6. If pressure gauges are installed before and after softening system, verify and record static and dynamic pressure, reporting pressure drop. Verify that inlet pressure respects valve and softening system limits. Make sure dynamic pressure always remain above 25.8 psi (1.78 bar) to ensure proper Magnum valve function.
7. If pressure gauges are not present, but suitable points exist, install temporary pressure gauge(s) to perform precedent point.

### 9.1.3 293 Regeneration test

1. Initiate manual regeneration and overserve flow to drain.
2. Make sure flow rate correspond to DLFC configuration.
3. Check for media loss at the drain during backwash.
4. Check to see if water runs clear at the end of the backwash cycle.
5. Where fitted, check for satisfactory operation of solenoid valve(s) i.e. outlet shut off during regeneration.

### 9.1.4 298 Regeneration test

1. Check condition of brine tank and any associated equipment.
2. Check salt level in brine tank.
3. Initiate regeneration test.
  - ⇒ Check brine draw during brine draw stage.
  - ⇒ Check brine tank refill.
  - ⇒ Check operation of safety brine valve, where fitted.
  - ⇒ Check for brine draw off levels.
  - ⇒ Check for resin loss at the drain during regeneration.
  - ⇒ Where fitted, check for satisfactory operation of solenoid, i.e. outlet shut off during regeneration and/or brine line shut off valve(s).
  - ⇒ If a Non Hard Water Bypass cartridge is fitted, make sure there is no water at outlet during regeneration.
4. Test and record Total Hardness of outlet water from softener vessel(s).

## 9.2 293-298 CV / IT: Recommended maintenance plan

Items	1 year	2 year	3 year	4 year	5 year
Injector & filter (for 298 only)	Clean	Clean	Clean / replace if necessary	Clean	Clean
Refill controller** (for 298 only)	Clean	Clean	Clean / replace if necessary	Clean	Clean
DLFC**	Clean	Clean	Clean / replace if necessary	Clean	Clean
Cartridges****	-	-	-	Replace	-
Pilot Screen	Clean	Clean	Clean / replace if necessary	Clean	Clean
Pilot Flappers	-	-	-	-	Replace
Flappers spring	-	-	-	-	Replace

Items	1 year	2 year	3 year	4 year	5 year
O-Rings**	Check for watertightness / clean or replace in case of leakage	Check for watertightness / clean or replace in case of leakage	Check for watertightness / clean or replace in case of leakage	Check for watertightness / clean or replace in case of leakage	Check for watertightness / clean or replace in case of leakage
Motor, motor cable and optical sensor harness	Check	Check	Check	Check	Replace
Optical sensor	Check	Check	Check	Check	Replace
Electronic / settings*	Check	Check	Check	Check	Check / replace if necessary
Transformer*	Check	Check	Check	Check	Check / replace if necessary
Internal Turbine (IT model, if present)***	Check / clean / replace if necessary	Check / clean / replace if necessary	Replace	Check / clean / replace if necessary	Check / clean / replace if necessary
External Turbine (Cv model, if present)***	Check / clean	Check / clean	Check / clean	Check / clean	Replace
Turbine cable (if turbine present)	Check	Check	Check	Check	Replace
Valve watertightness	Check	Check	Check	Check	Check
Valve to piping watertightness	Check	Check	Check	Check	Check

\* Electronical parts – durability strongly affected by power source quality and stability

\*\* Elastomer durability is strongly affected by raw water concentration in chlorine and its derivate

\*\*\* Wear part

\*\*\*\* Cartridges tends to stick to valve body after some months in service and might be damaged when unmounting. Prefer to remove cartridges only when it must be replaced. Cartridges must not be unmounted for troubleshooting investigations but only when exchange is really required. Report to chapter Magnum valve cartridge [→Page 87] for complete troubleshooting guide and to chapter Cartridge replacement [→Page 81] for proper assembly/disassembly procedure.

## 9.3 298 CV / IT: General system inspection

### Mandatory



Has to be done once a year at minimum.

### 9.3.1 Water quality

1. Check for raw water analysis and filter's targeted contaminants concentration.
2. Check for treated water analysis and compare with raw water data.

### 9.3.2 Mechanical checks

1. Inspect general condition of valve and associated ancillaries and check for any leaks, ensure valve connection to piping is made with adequate flexibility as per manufacturer instruction.
2. Inspection of electrical connections, verify wiring connections and search for evidence of overloading.
3. Verify settings of electronic timer, verify regeneration frequency, make sure the valve configuration corresponds to the settings.
4. Check water meter, if present, report water meter settings and compare with previous inspection.
5. Verify total water consumption compared to previous visit.
6. If pressure gauges are installed before and after softening system, verify and record static and dynamic pressure, reporting pressure drop. Verify that inlet pressure respects valve and softening system limits. Make sure dynamic pressure always remain above 25.8 psi (1.78 bar) to ensure proper Magnum valve function.
7. If pressure gauges are not present, but suitable points exist, install temporary pressure gauge(s) to perform precedent point.

## 9.4 Recommendations

### 9.4.1 Use original spare parts

#### Caution - material



#### **Risk of damage due to use of non-genuine spare parts**

To ensure correct operation and safety of the device, only use original spare parts and accessories recommended by the manufacturer.

Usage of non-genuine spare parts voids all warranties.

---

Parts to keep in stock for potential replacements are motor and optical sensor, controller, transformer, injectors, flapper kit, O-ring kit, refill flow controller and DLFC.

### 9.4.2 Use original approved lubricants

- Dow corning #7 Release Agent;
- spare part: p/n 1014081 (NAM) – 42561 (EMEA), (SILICONE LUBRICANT PACK).

### 9.4.3 Maintenance instructions

- Disinfect and clean the system at least once a year or if the treated water has an off-taste or an unusual odor;
- perform a hardness test every year at both inlet and treated water.

## 9.5 Cleaning and maintenance

### 9.5.1 First steps

Before any cleaning or maintenance procedure, complete the following steps:

#### Mandatory



**These operations must be performed before any cleaning or maintenance procedure!**

1. Unplug the wall-mounted transformer.
2. Shut off water supply or put bypass valve(s) into bypass position.
3. Relieve system pressure before performing any operations.

### 9.5.2 Injector cleaning

1. Using a pliers if needed, unscrew and remove the injector cap **(1)**.

#### Caution - material



**Take care not to damage the injector (3).**

2. Check for O-rings integrity.
3. Clean the screen injector **(2)** and injector **(3)** using compressed air, a soft brush or possibly a pin.
4. Reverse above procedure steps to rebuild.

### 9.5.3 Refill controller cleaning

1. Using a pliers if needed, unscrew and remove the refill controller **(4)**.
2. Clean the refill controller **(4)** with a soft brush.
  - ⇒ Make sure the refill controller groove is perfectly clean.
3. Check for O-rings integrity.
4. Clean the refill controller chamber **(5)** before reinserting the refill controller **(4)**.
5. Reverse above procedure steps to rebuild.

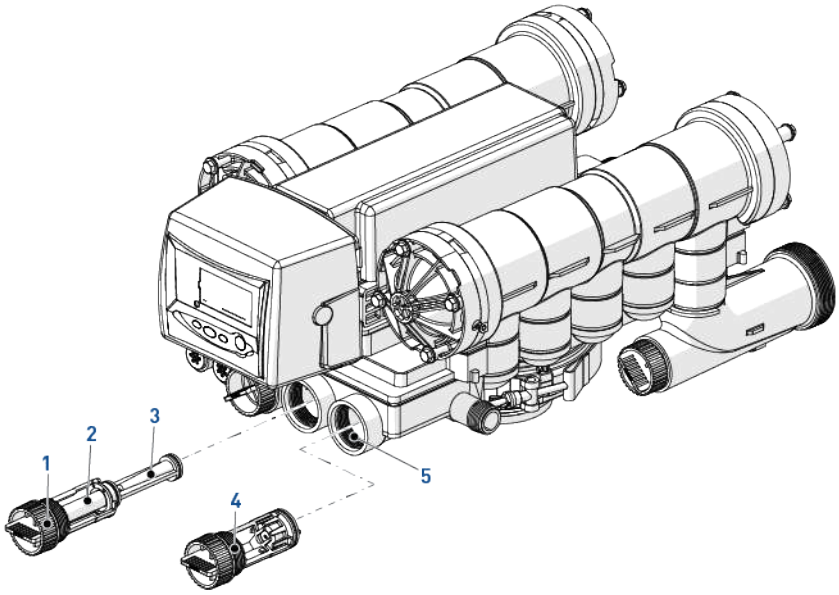

### 9.5.4 Pilot filter screen cleaning

1. Using a Torx key, unscrew and extract the injector screen cap **(1)**.
2. Unclip the white plastic basket **(2)** and clean it with a soft brush. Use of descaling agent such as white vinegar might be required in case of impurities on the plastic basket **(2)**.
3. Check for O-rings integrity before reinserting the injector screen cap **(1)**.
4. Reverse above procedure steps to rebuild.

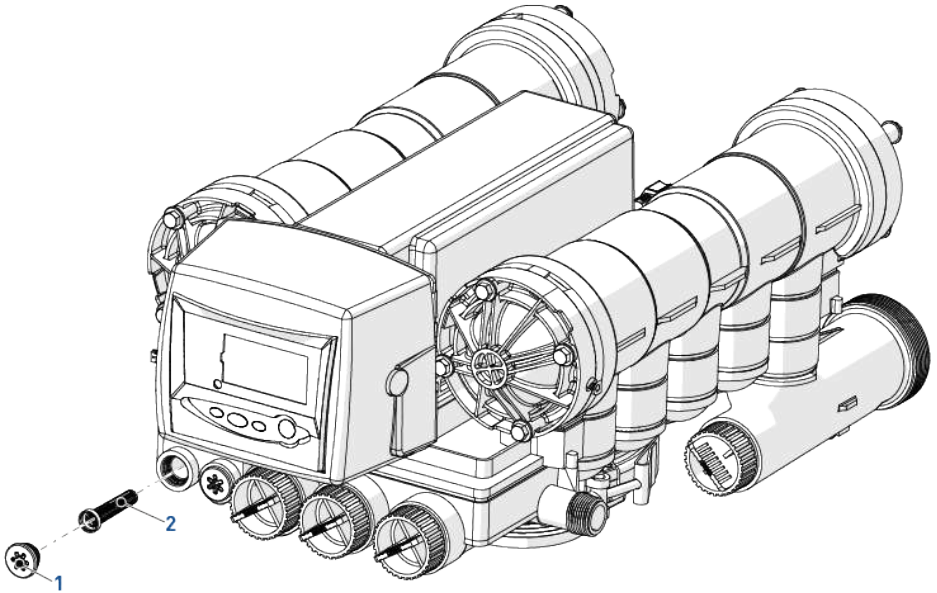

### 9.5.5 Controller cover disassembly

1. Unlock the controller cover **(1)** from the slide clips **(4)** (one on each side of the valve).
2. Pull straight off the controller cover **(1)**.
3. Reverse above procedure steps to rebuild.

### 9.5.6 Camshaft cover disassembly

1. Unlock the camshaft cover **(2)** from the slide clips **(3)** (one on each side of the valve).
2. Pull off the camshaft cover **(2)**.
3. Reverse above procedure steps to rebuild.

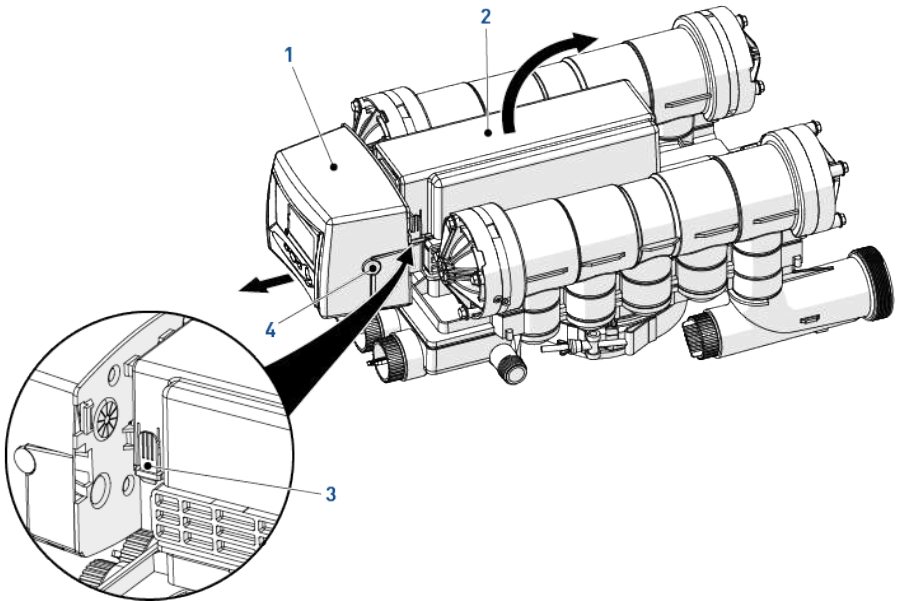

### 9.5.7 Motor replacement

1. Remove the controller cover (1). See Controller cover disassembly [→Page 74].
2. Press the controller locking pad (4) and slide the controller (2) out of its position.
3. Loosen the two screws (6).
4. Remove the motor (5).
5. Disconnect the motor cable (3) from the controller (2).

#### Info



To replace the motor, you also have to disassemble the optical sensor. See Optical sensor and controller replacement [→Page 77].

6. Reverse above procedure steps to rebuild.

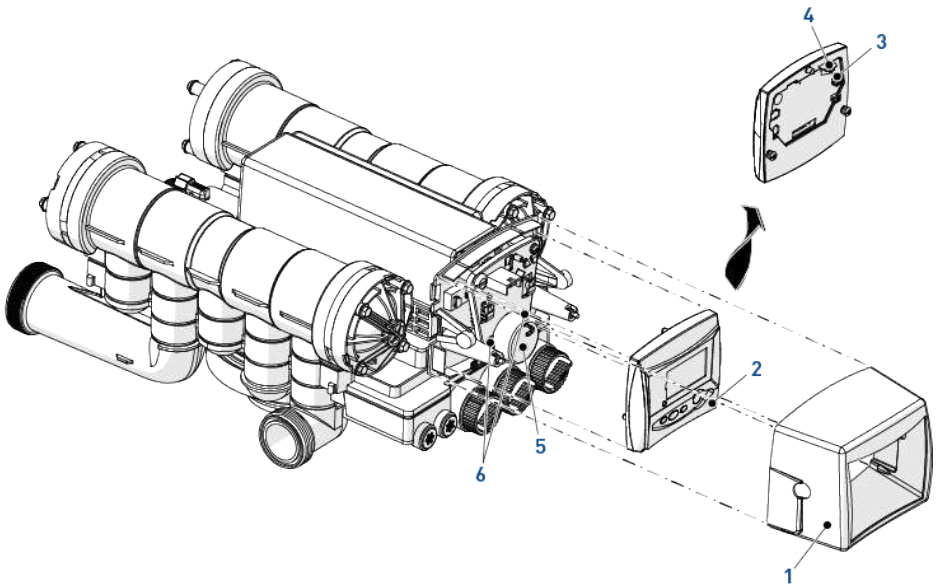

### 9.5.8 Camshaft replacement

1. Remove the camshaft cover **(1)**. See Camshaft cover disassembly [→Page 74].
2. Press on the release tab **(9)** and pull on the back end of the camshaft **(2)**.
  - ⇒ The front end of the camshaft will be flush with the mounting plate **(6)**.
3. Loosen the four screws **(3)** and **(5)**.
4. Remove the two pillow blocks **(7)** and **(8)**.
5. Remove the camshaft **(4)**.
6. Reverse above procedure steps to rebuild.

#### Info



**When reassembling the camshaft **(4)**, place it through the mounting plate **(6)**. Rotate the cam assembly counter-clockwise until the camshaft arrow **(10)** aligns with pillow block arrow **(11)**. Then engage the camshaft with the controller.**

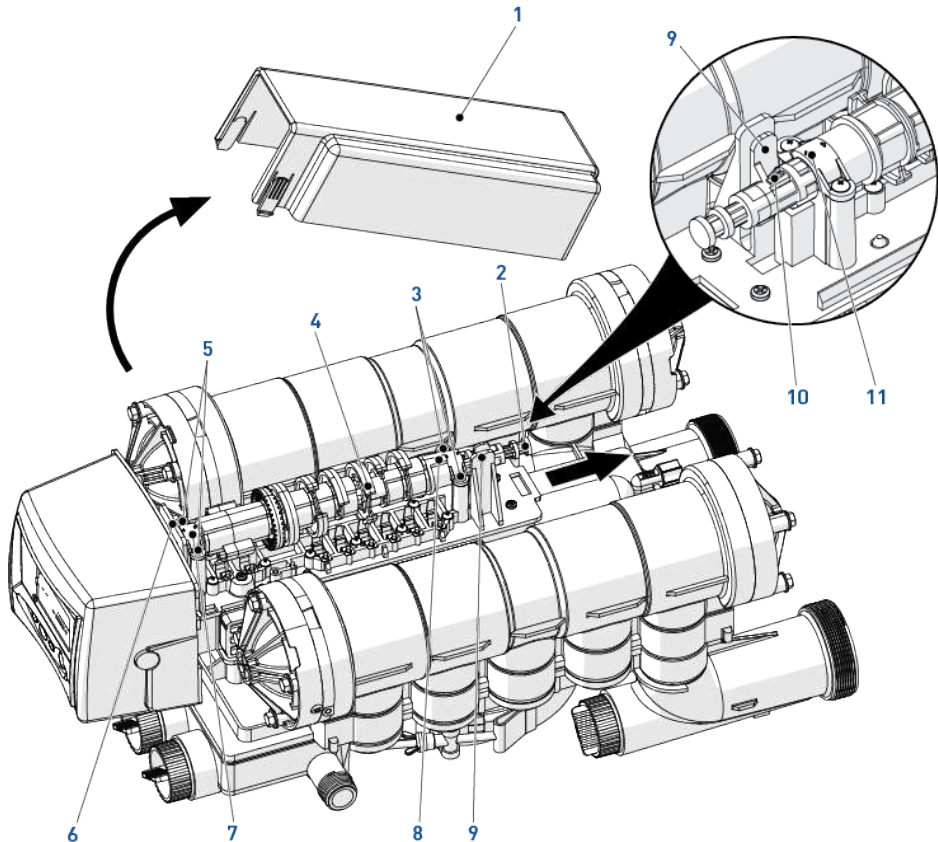

### 9.5.9 Optical sensor and controller replacement

1. Remove the controller cover **(1)**. See Controller cover disassembly [→Page 74].
2. Press the controller locking pad **(3)** and slide the controller **(2)** out of its position.
3. Loosen the four screws **(4)**.
4. Remove the plate **(7)** and the wheel **(6)**.
5. The optical sensor **(5)** is clipped on the front edge, gently press on the clips to release the optical sensor from its location.
6. Disconnect the cables from the controller by pressing on the clip and pulling them.

#### Info



To replace the optical sensor, you also have to disassemble the motor. See Motor replacement [→Page 75].

7. Reverse above procedure steps to rebuild.

#### Caution - material



When refitting, always use the cables guide to secure the cables. This will prevent the cables from being crushed or cut when closing the cover.

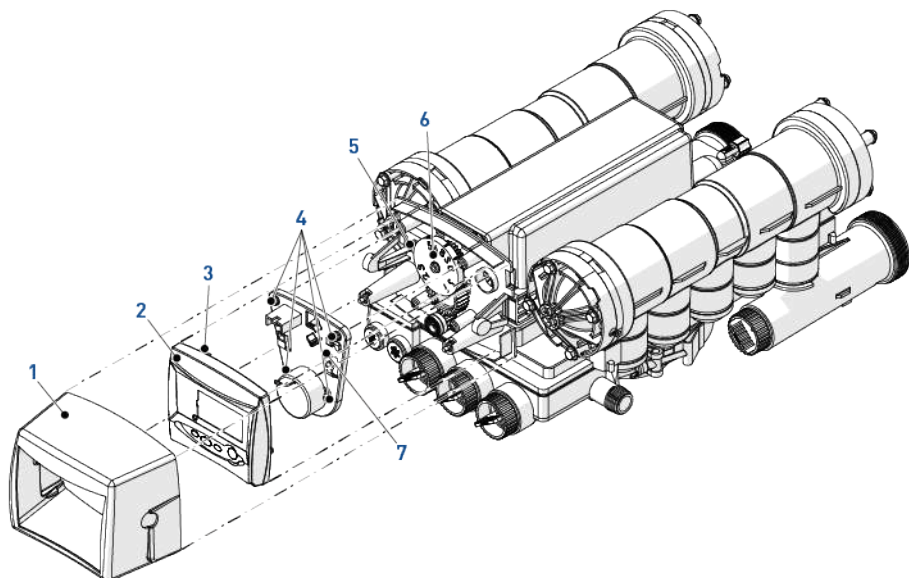

## 9.5.10 Turbine cleaning or replacement

### Info



Depending on the valve installation, the turbine may not be present in the valve.  
(Magnum IT : internal turbine/Magnum Cv : external turbine).

1. Using a pliers if needed, unscrew and remove the turbine **(3)** from the outlet pipe **(1)** of the valve.
2. Clean the turbine **(2)** using a soft cloth and a brush.
3. Reverse above procedure steps to rebuild.

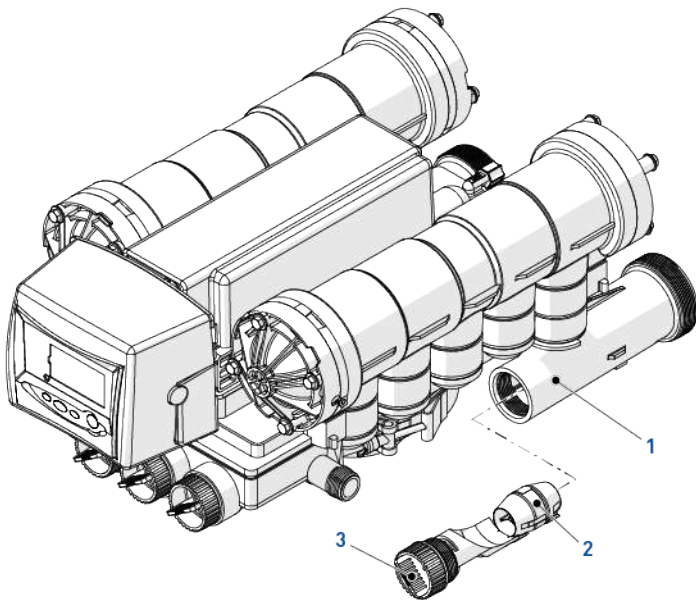

## 9.5.11 Top plate and disc valve replacement

1. Remove the camshaft cover. See Camshaft cover disassembly [->Page 74].
2. Remove the camshaft. See Camshaft replacement [->Page 76].

### CAUTION



#### Take care with sharp edges.

Use of protective glove is highly recommended to release or re-move the springs **(1)**.

3. Using a flat screwdriver, release the flapper springs **(1)** one by one (8x).
4. Loosen all top plate screws **(3)** (14x).
5. Remove the top plate **(2)** from the valve.
6. Clean or replace the flappers **(4)** if needed.

### Info



#### The outline of the flapper seat can be seen on the flapper side.

If the outline is irregular, this may indicate that debris is or has been preventing the flapper **(4)** from closing, and potential damage.

### Info



#### When refitting the top plate **(2)**, always follow the screwing order below.

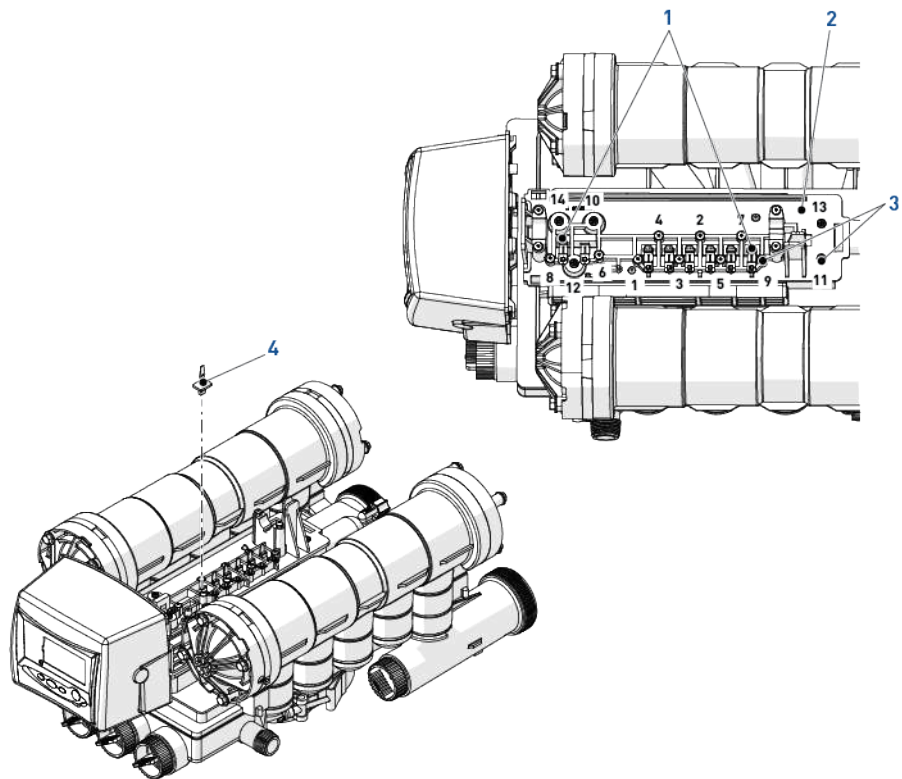

## 9.5.12 Cartridge replacement

### Info



Removal of cartridges should be done only after reviewing all other possible causes of problem (see Magnum valve cartridge [→Page 87]).

### Info



There may be some difficulties to remove cartridges in valves that have been in service for a long period of time.

Scale or iron build up around the O-ring seals may cause breakage in the cage assembly of the cartridge.

### Info



The controller must be removed first before removing #1 drain cartridge or #2 rinse cartridge.

1. Using a combination wrench, remove the four bolts **(1)**.
2. Using a flat screwdriver, pry a small opening between the valve body and the second part of the cartridge.

### Caution - material



**There are two parts or sections in the cap of the cartridge assembly.**

The first part is a cover for the diaphragm. The second part is attached to the main cartridge assembly. Insert the screwdriver between the valve body and the second part of the cartridge assembly **(2)**.

3. Insert two larger flat screwdrivers at the 10 o'clock and 2 o'clock positions of the cartridge.
  - ⇒ These should be inserted approximately  $\frac{25}{64}$ " [1 cm] into the opening created by the small screwdriver. Use then the two screwdrivers to slowly move the cartridge **(4)** out of the valve body.
4. Inspect, clean and/or replace the damaged part of the valve cartridge.
5. Reverse above procedure steps to rebuild.

### Info



Check that the nipples O-rings **(3)** are in place when the cartridge is rebuild into the valve body.

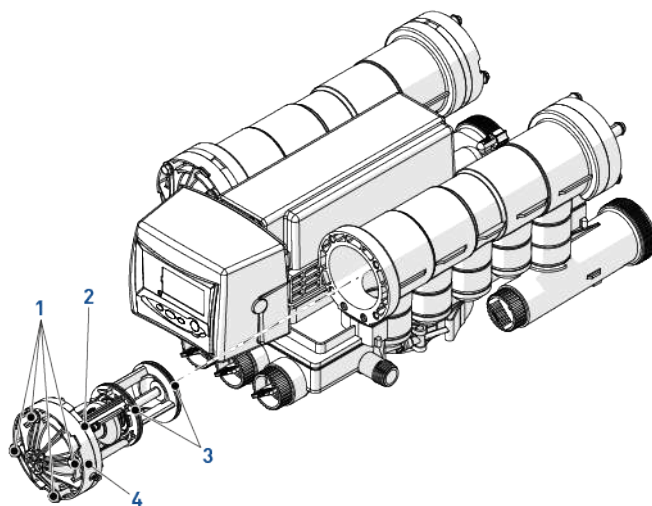

## 10 Troubleshooting

### 10.1 Logix controller

Err. code	Cause	Solution
ERR 1	Controller power has been connected and the controller is not sure of the operating status.	Reset controller. See Resetting the controller [→Page 60].
ERR 2	Controller power does not match 50 or 60 Hz.	Disconnect and reconnect the power. If problem is not solved, obtain an appropriate controller or AC transformer.
ERR3	Controller lost the position of camshaft. Camshaft should be rotating to find Home position.	Wait for 2 minutes: the controller returns to Home position. An hourglass icon flashes to indicate that the motor is running.
	Camshaft does not rotate.	Check: <ul style="list-style-type: none"> <li>• Motor connections.</li> <li>• If motor wire harness is connected to the motor.</li> <li>• If motor wire harness is connected to the controller.</li> <li>• Optical sensor connection and position.</li> <li>• If motor and camshaft gears are engaged.</li> </ul>
	Camshaft rotates for more than 5 minutes to find Home position.	If everything is connected, try replacing in this order: <ul style="list-style-type: none"> <li>• Wire harness.</li> <li>• Motor.</li> <li>• Optical sensor.</li> <li>• Controller.</li> <li>• See Cleaning and maintenance [→Page 71].</li> </ul>
	Camshaft rotates for more than 5 minutes to find Home position.	Check: <ul style="list-style-type: none"> <li>• Optical sensor connection and position.</li> <li>• Camshaft connection.</li> <li>• Camshaft slots cleanness.</li> </ul>

Err. code	Cause	Solution
ERR3	Camshaft rotates for more than 5 minutes to find Home position.	If motor keeps rotating indefinitely, replace the following components in this order: <ul style="list-style-type: none"> <li>• Wire harness.</li> <li>• Motor.</li> <li>• Optical sensor.</li> <li>• Controller.</li> <li>• See Cleaning and maintenance [→Page 71].</li> </ul>
ERR4	Controller on tank 2 does not know the position of the camshaft. Camshaft should be rotating to find Home position.	Wait for two minutes, the controller will return to home position. The hourglass should be flashing on the display indicating the motor is running.
	Camshaft on tank 2 is not turning when ERR 4 is displayed.	Check that motor is connected. Verify that motor wire harness is connected to the motor and controller module. Verify that optical sensor is connected and in place. Verify that motor gear has engaged cam gear. If everything is connected, try replacing in this order: <ul style="list-style-type: none"> <li>• wire harness, motor, optical sensor assembly;</li> <li>• controller.</li> </ul>
	Camshaft on tank 2 is turning for more than five minutes to find Home position.	Verify that optical sensor is in place and connected to wire. Verify that camshaft is connected. Verify that no dirt or rubbish is clogging any of the cam slots. If motor continues to rotate indefinitely, replace the following components in this order: <ul style="list-style-type: none"> <li>• wire harness, motor, optical sensor assembly;</li> <li>• controller.</li> </ul>
	Regeneration starts but controller shows ERR 4 before completing the regeneration.	Verify that the correct valve is selected in the Logix controller.

Err. code	Cause	Solution
-- : --	Power failure occurred.	Press  to reset the time.

## 10.2 Magnum IT and Cv valve

Issue	Cause	Solution
Water softener fails to regenerate (no soft water).	Power supply to the Magnum controller has been interrupted.	<ul style="list-style-type: none"> <li>Determine the reason for power interruption and correct it;</li> <li>reset the time of day.</li> </ul>
	Water pressure lost.	<ul style="list-style-type: none"> <li>Restore water pressure.</li> </ul>
	Logix controller improperly programmed.	<ul style="list-style-type: none"> <li>Verify that the Logix controller is properly programmed.</li> </ul>
	Defective controller.	<ul style="list-style-type: none"> <li>Replace the controller assembly. See Controller cover disassembly [<a href="#">→Page 74</a>].</li> </ul>
	No salt in the brine tank.	<ul style="list-style-type: none"> <li>Add salt and regenerate in the tank.</li> </ul>
	Manual bypass valve is open.	<ul style="list-style-type: none"> <li>Close the manual bypass valve.</li> </ul>
	For 762 series controller, turbine meter is clogged or restricted.	Inspect turbine meter assembly, clean or replace it. See Turbine cleaning or replacement [ <a href="#">→Page 78</a> ].
	Leak at riser pipe seal.	<ul style="list-style-type: none"> <li>Ensure that riser pipe is properly sealed at the tank adapter o-ring;</li> <li>inspect pipe for cracks.</li> </ul>
	Insufficient brine.	<ul style="list-style-type: none"> <li>Check refill controller and clean if necessary;</li> <li>check controller settings;</li> <li>check flow rate capacities of safety float and air check assembly.</li> </ul>
No brine draw.	Plugged injector and/or injector screen.	<ul style="list-style-type: none"> <li>Inspect and clean injector and/or injector screen.</li> </ul>
	Insufficient water pressure.	<ul style="list-style-type: none"> <li>Increase water pressure above 25 psi (172 kPa) minimum.</li> </ul>
	Obstructed drain line.	<ul style="list-style-type: none"> <li>Remove the obstruction.</li> </ul>
	Brine line pulling air.	<ul style="list-style-type: none"> <li>Ensure all brine line fittings are tight.</li> </ul>

Issue	Cause	Solution
Insufficient brine draw.	Partially clogged injector and/or injector screen.	<ul style="list-style-type: none"> <li>Inspect and clean the injector and/ or injector screen assembly.</li> </ul>
	Restricted flow rate in brine line.	<ul style="list-style-type: none"> <li>Check flow rate capabilities of the safety float/air check assembly.</li> </ul>
	Insufficient water pressure.	<ul style="list-style-type: none"> <li>Increase water pressure above 25 psi (172 kPa) minimum.</li> </ul>
	Excessive back pressure on injector due to elevated drain line.	<ul style="list-style-type: none"> <li>Reduce drain line elevation to height of valve</li> </ul>
	Partially restricted drain line.	<ul style="list-style-type: none"> <li>Remove the restriction.</li> </ul>
Insufficient refill to brine tank.	Restricted flow rate in brine line.	<ul style="list-style-type: none"> <li>Check flow rate capabilities of the safety float/air check assembly.</li> </ul>
	Resin volume incorrectly set.	<ul style="list-style-type: none"> <li>Program again the controller.</li> </ul>
Excessive water in brine tank.	Plugged drain line flow control.	<ul style="list-style-type: none"> <li>Clean the drain line flow control.</li> </ul>
	Plugged injector and/or injector screen.	<ul style="list-style-type: none"> <li>Inspect and clean the injector and/ or injector screen assembly.</li> </ul>
	Incorrect refill controller.	<ul style="list-style-type: none"> <li>Install the correct controller.</li> </ul>
	Insufficient water pressure.	<ul style="list-style-type: none"> <li>Ensure that operating pressure is above 25 psi (172 kPa).</li> </ul>
Leak to main drain.	No flow control installed in drain line.	<ul style="list-style-type: none"> <li>Install drain line flow control.</li> </ul>
	Insufficient water pressure.	<ul style="list-style-type: none"> <li>Increase water pressure above 25 psi (172 kPa) minimum.</li> </ul>
	Plugged injector and/or injector screen.	<ul style="list-style-type: none"> <li>Inspect and clean the injector and/ or injector screen assembly.</li> </ul>
	Back pressure on pilot drain port.	<ul style="list-style-type: none"> <li>Plumb pilot drain line to atmospheric position (i.e brine tank).</li> </ul>
Loss of media to drain.	No flow control installed in drain line.	<ul style="list-style-type: none"> <li>Install drain line flow control.</li> </ul>
	Air or gasses in raw water.	<ul style="list-style-type: none"> <li>Ensure that air or gasses are not present in feed water.</li> </ul>
	Unit draws air through brine line.	<ul style="list-style-type: none"> <li>Ensure that all brine line fittings are tight and that the aircheck closes.</li> </ul>
	Defective air check.	<ul style="list-style-type: none"> <li>Clean or replace aircheck.</li> </ul>
Loss of water pressure.	Fouled resin bed due to iron accumulation.	<ul style="list-style-type: none"> <li>Clean Magnum control valve and mineral bed with cleaner.</li> </ul>
	Slots in riser pipe or laterals are filled with resin fines.	<ul style="list-style-type: none"> <li>Inspect and clean distributor pipe slots as needed.</li> </ul>

Issue	Cause	Solution
Salt in water to service after regeneration.	The injector is too small for the system size.	<ul style="list-style-type: none"> <li>Install the correct injector.</li> </ul>
	Brine draw time excessively long due to low water pressure.	<ul style="list-style-type: none"> <li>Increase water pressure above 25 psi (172 kPa) minimum.</li> </ul>
	Restricted drain line.	<ul style="list-style-type: none"> <li>Remove drain line restriction.</li> </ul>
	Insufficient rinse volume.	<ul style="list-style-type: none"> <li>Increase slow rinse time, fast rinse time or both.</li> </ul>
	Plugged injector and/or injector screen.	<ul style="list-style-type: none"> <li>Inspect and clean the injector and/ or injector screen assembly.</li> </ul>

### 10.3 Magnum valve cartridge

The following procedure provides sequential troubleshooting steps to isolate a suspect cartridge.

#### Info



**The dynamic pressure applied to the valve must be greater than 25 psi (172 kPa) at all times when performing the following tests.**

If a cartridge needs to be removed, follow the removal procedure in section Cartridge replacement [→Page 81].

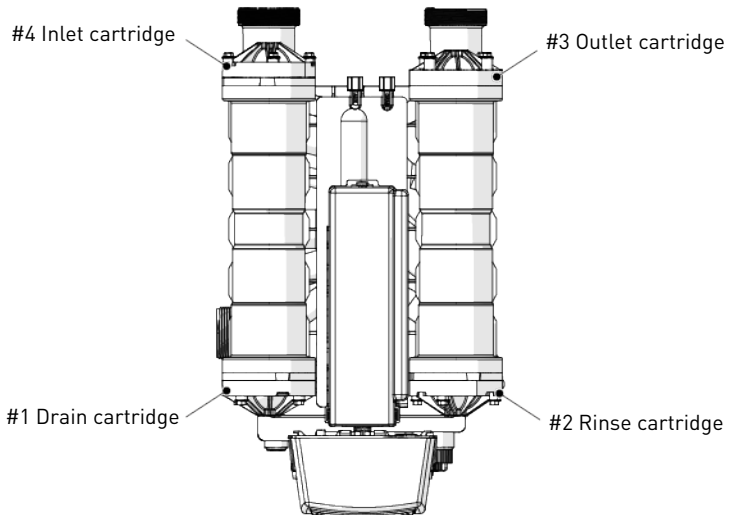

There are four symptoms that may require a cartridge to be removed and inspected or replaced.

1. A constant leak from the pilot drain in any cycle position.

A small discharge of water from the pilot drain while transitioning from one cycle to the next is normal. A leak from the pilot drain could be caused by the following:

- ⇒ Diaphragm failure in one of the valve cartridges. See table below for faulty cartridges.

- ⇒ Debris may prevent the flappers from closing.  
Inspect discs and seats. Quick cycle the Logix Magnum to each cycle indicated below. If the leak stops in a particular cycle, remove the cartridge listed in the right column. Inspect for wear or damage.

No leak during	Cartridge
Service cycle (C0)	#3 Outlet
Backwash (C1)	#1 Drain
Brine (C2)/Slow rinse (C3)	#2 Rinse
Fast rinse (C5)	#2 Rinse or #4 Inlet

1. A leak to the main 1.5" drain valve port.
  - ⇒ If the system is newly installed, ensure that the start-up procedure has been properly followed.  
Refer to chapter Commissioning
  - ⇒ If the system has been operating correctly for a period of time and is now leaking, regenerate the unit if the media bed is exhausted. Then proceed as follow.
2. Test the water leaking from the 1.5" drain port of the Magnum valve:
  - ⇒ If it is treated, remove and inspect the #2 Rinse cartridge.
  - ⇒ If it is untreated, remove and inspect the #1 Drain cartridge.
3. Leakage of untreated water to service.
  - ⇒ Leak at riser pipe seal or any other cause mentioned in this troubleshooting chapter.
  - ⇒ Bypassing of untreated water by #4 Inlet cartridge. Remove and inspect it.
4. Leak between the main valve body and the cartridge assembly.
  - ⇒ Remove and replace the two small O-rings at 5:30 and 6:30 positions of the cartridge (see Magnum cartridges [→Page 94]).

**Info**

**Replacement cartridges are only available as complete assemblies.**

Cartridge #1	Drain	P/N 1000366
Cartridge #2	Fast rinse	P/N 1000365
Cartridge #3	Service	P/N 1000366 (No bypass)
		P/N 1000336 (Cap only for bypass)
Cartridge #4	Inlet	P/N 1000317

## 11 Spare parts

### 11.1 Magnum connections

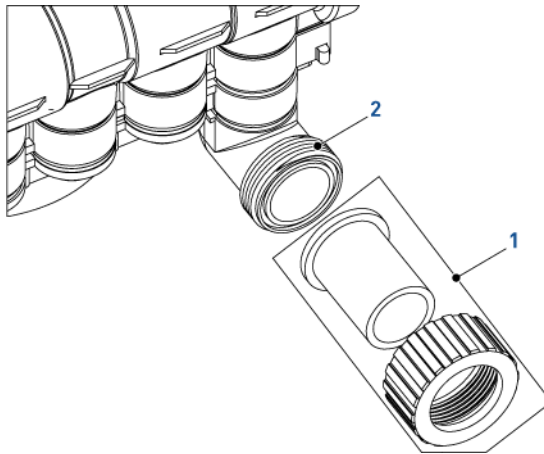

Item	Part number NAM	Part number EMEA	Description
1	/	1001656	293/298 Cv 1 1/2" (38.1 mm) - 1 31/32" (50 mm) PVC adapter kit
-	/	3023673	293/298 Cv 1 1/2" (38.1 mm) - 1 1/2" (38.1 mm) BSP Stainless Steel adapter kit
-	/	3023674	293/298 IT 2" (50.8 mm) - 2" (50.8 mm) BSP Stainless Steel adapter kit
-	1040784-01	1040784	293/298 IT 2" (50.8 mm) - 2" (50.8 mm) PVC adapter kit
-	/	1040785	293/298 IT 2" (50.8 mm) - 2 31/64" (63.1 mm) PVC adapter kit
2	1010162	1010162	O-ring tank adaptor
*	/	1040691	Kit Oring 293/298 (4x1010160, 1x1010162&65)
*	3029252	3029252	4" (101.6 mm) SS adapter 293/298
*	1040921-01	1040921S	Side Mount Adapter BSP 293/298 w Plug 2" (50.8 mm)

\* not shown

/ not available

## 11.2 Magnum Logix camshaft and pilot

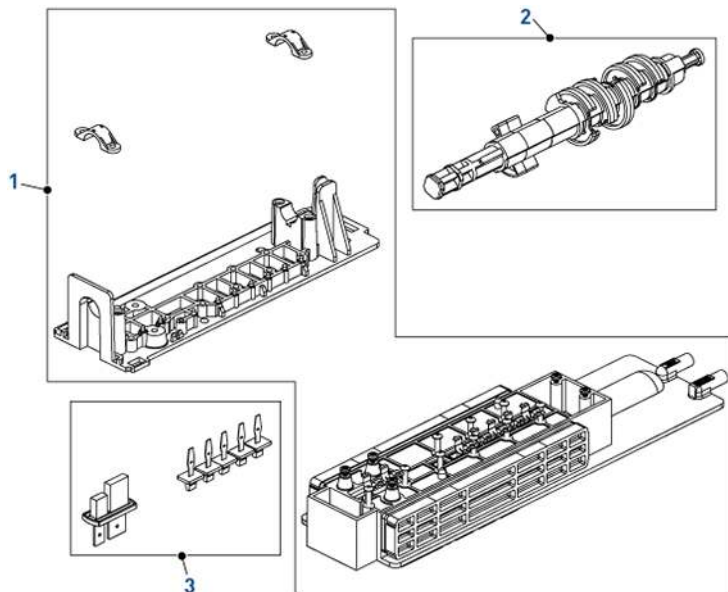

Item	Part number NAM	Part number EMEA	Description
1	4000632	4000632	Kit Top plate, pillow blocks, screws 293/298
2	4000633	4000633	Camshaft Logix 298 Twin & SGL
3	1040692-01	1040692	Kit flappers and springs

### 11.3 Magnum refill controller assembly

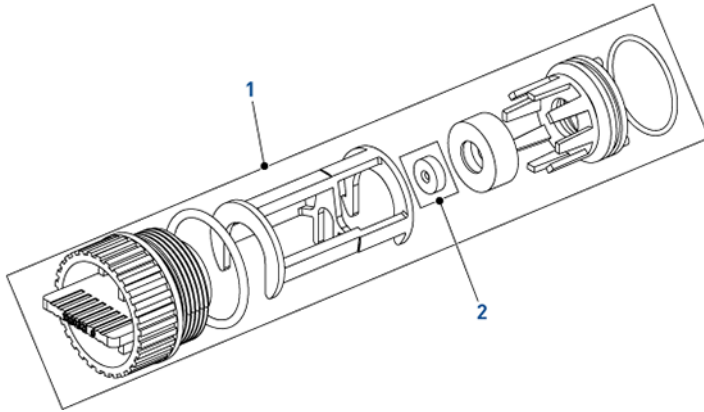

Item	Part number NAM	Part number EMEA	Description
1	/	1040687	Refill control assy w/o washer 293-298
2	/	1000421	Refill flow control 14" tank 0.7 gpm (0.19 m <sup>3</sup> /h)
-	/	1000422	Refill flow control 16" tank 0.8 gpm (0.22 m <sup>3</sup> /h)
-	/	1000423	Refill flow control 18" tank 1 gpm (0.27 m <sup>3</sup> /h)
-	1000424	1000424	Refill flow control 21" tank 1.4 gpm (0.38 m <sup>3</sup> /h)
-	1000425	1000425	Refill flow control 24" tank 2 gpm (0.55 m <sup>3</sup> /h)
-	1000426	1000426	Refill flow control 30" tank 3 gpm (0.81 m <sup>3</sup> /h)
-	1000427	1000427	Refill flow control 36" tank 5 gpm (1.36 m <sup>3</sup> /h)

/ not available

## 11.4 Magnum injector assembly

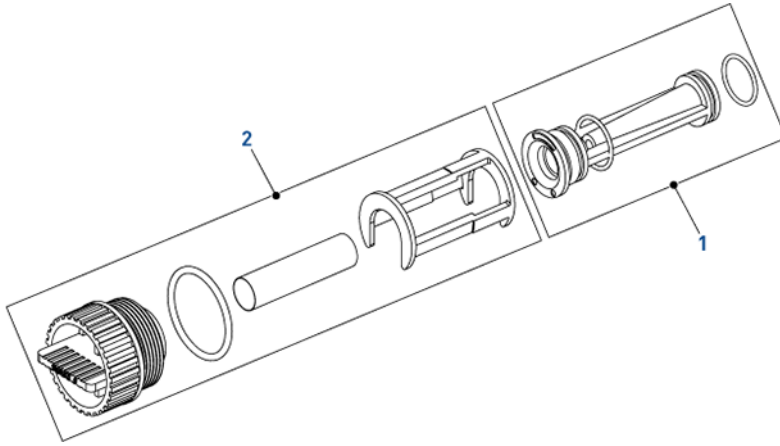

Item	Part number NAM	Part number EMEA	Description
1	/	1040670	Injector for 14" (35.6 cm) tank - 0.5 gpm (0.14 m <sup>3</sup> /h)
-	/	1040671	Injector for 16" (40.6 cm) tank - 0.5 gpm (0.14 m <sup>3</sup> /h)
-	/	1040672	Injector for 18" (45.7 cm) tank - 0.6 gpm (0.16 m <sup>3</sup> /h)
-	1040673	1040673	Injector for 21" (53.3 cm) tank - 0.9 gpm (0.25 m <sup>3</sup> /h)
-	1040674-01	1040674	Injector for 24" (61 cm) tank - 1.4 gpm (0.38 m <sup>3</sup> /h)
-	1040675-01	1040675	Injector for 30" (76.2 cm) tank - 2.0 gpm (0.55 m <sup>3</sup> /h)
-	1040676-01	1040676	Injector for 36" (91.4 cm) tank - 3.3 gpm (0.9 m <sup>3</sup> /h)
-	1040669-01	1040669	Blank injector
2	1040677	1040677	Injector assy (less injector)

/ not available

## 11.5 Magnum drain line flow controls assembly

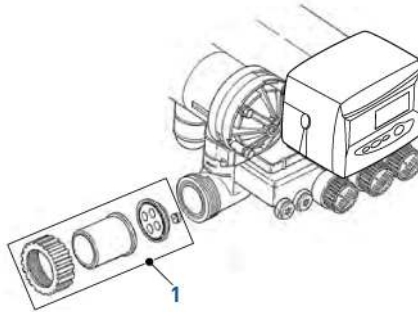

Item	Part number NAM	Part number EMEA	Description
1	1040762-01	1040762	DLFC disc w/o Flow Control inserts
*	/	4000630	Kit DLFC 293 Filter Washer all sizes
*	/	4000631	Kit DLFC 298 Softener Washer all sizes

\* not shown

/ not available

## 11.6 Magnum cartridges

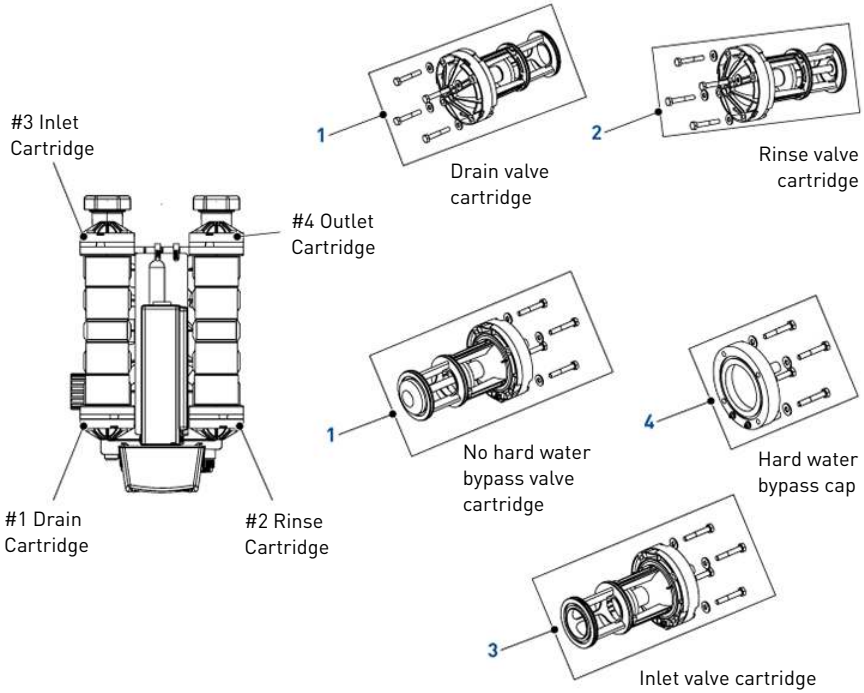

Item	Part number NAM	Part number EMEA	Description
1	1000366-01	1000366	Drain valve, no hard water bypass valve cartridge
2	1000365-01	1000365	Rinse valve cartridge
3	1000317-01	1000317	Inlet valve cartridge
4	1000336	1000336SP	Hard water bypass cap
*	1040689	1040689	Kit sealing 293/298 Cartridges

\* not shown

## 11.7 Magnum Logix controllers

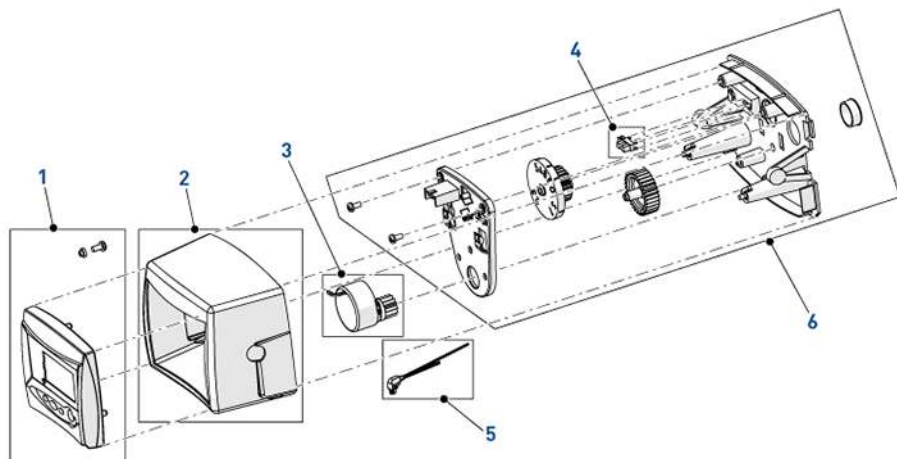

Item	Part number NAM	Part number EMEA	Description
1	3003194	1265832	Timer Logix 742F Magnum
-	/	1265835	Timer Logix 762 Magnum
*	3022006	3030409	Logix 764 controller - picto
2	1254886	1254886	Secondary faceplate
3	3029221	1238861	Motor + cable Logix/EiQ series controller, 12V 50/60 Hz
4	1235373	1235373	Module, sensor, photo interrupter
5	1266722	1266722	Turbine cable, Logix, 32" [81.2 cm] (Magnum IT Logix)
-	/	1266723	Turbine cable, Logix, 10ft [3 m] (Magnum CV Logix)
6	/	1233809	Backplate Assy for Logix Magnum Control
*	/	1000813	Wall mount transformer 220V/12V UK
*	/	1000814	Wall mount transformer 220V/12V EUR
*	3016715	3016715	Y sensor cable connector Twin
*	3016775	3016775	Interconnecting cable Twin
*	3020228	3020228	Remote start, lockout cable L versions

\* not shown

/ not available

## 11.8 Magnum IT turbine

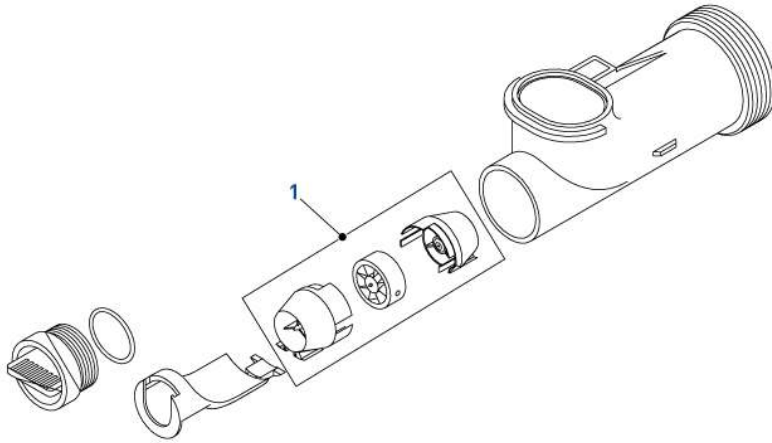

Item	Part number NAM	Part number EMEA	Description
1	1232965	1232965SP	Assy 1" (25.4 mm) IT Turbine 293/298 2" (50.8 mm) elbow

## 11.9 2" external turbine assembly

Item	Part number NAM	Part number EMEA	Description
*	1033358	1033358	2" (50.8 mm) turbine only
*	/	3023537	2" (50.8 mm) turbine assy with 2" (50.8 mm) stainless steel BSP adapters
*	1010165	1030891	Gasket, 2" (50.8 mm)

\* not shown

/ not available

### 11.10 Magnum miscellaneous

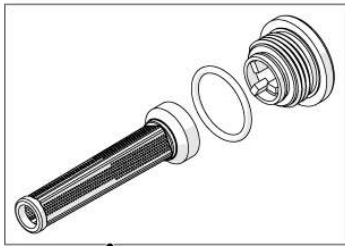

1 Kit Switch

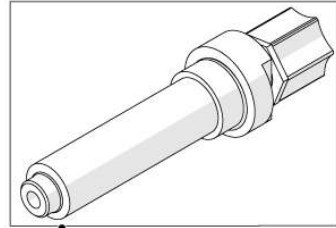

2 External pilot feed adapter

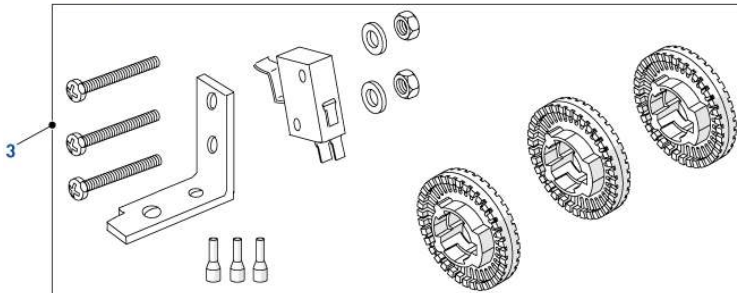

Pilot screen assembly

Item	Part number NAM	Part number EMEA	Description
*	1239979	1239979	Cable harness for remote regeneration
1	1000226	1000226	Pilot screen assy includes pilot screen, pilot screen cap & O-ring
2	1040668	1040668	External pilot feed adapter (separate source pilot water)
3	3019523	3019523	KIT Switch 5A. Single tank w/ breakaway cam

\* not shown

### 11.11 Magnum 293/298 installation components

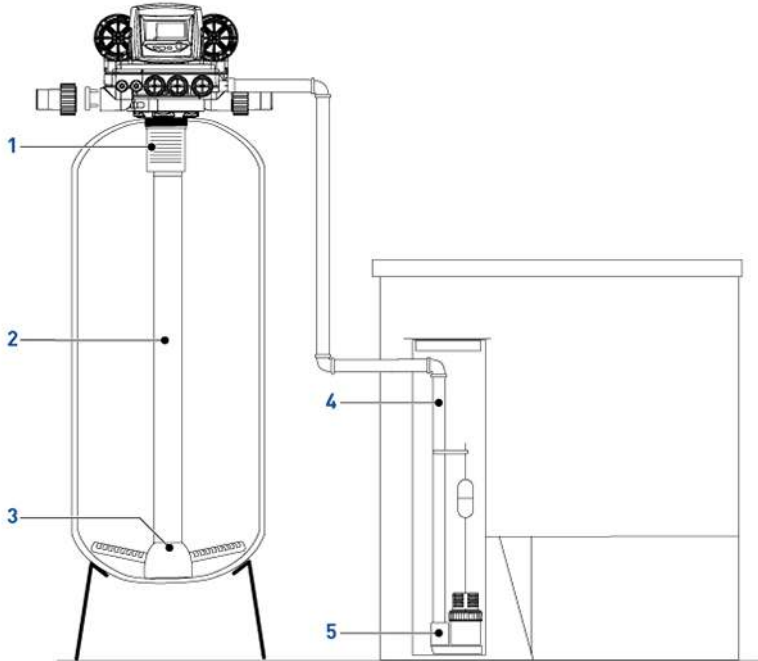

Item	Part number NAM	Part number EMEA	Description
1	1009115	1009115	Upper screen
2	/	3028330	Riser tube 1.5" (38.1 mm), ID 1.9" (48.3 mm) OD, 6.6 ft (2 m) long
3	/	1037112	Lower distributor for 18" (45.7 cm), 21" (53.3 cm) and 24" (60.9 cm) vessels
4	/	18979	Aircheck tube 1/2" (12.7 mm) for SBV 2350, 6.17 ft (1m88)
5	/	25453	SBV 2350 without air check

/ not available

## 12 Disposal

The device must be scrapped in accordance with directive 2012/19/EU or the environmental standards in force in the country of installation. The components included in the system must be separated and recycled in a waste recycling center that conforms with the legislation in force in the country of installation. This will help to reduce the impact on the environment, health, safety and help to promote recycling. Pentair does not collect used product for recycling. Contact your local recycling center for more information.



**WWW.PENTAIR.EU**  
**WWW.PENTAIR.COM**