

Fleck 2850 AiQ



IMPORTANT SAFETY INSTRUCTIONS

Read and follow all instructions
Save these instructions

WWW.PENTAIR.EU
WWW.PENTAIR.COM

Table of Contents

| | | |
|----------|--|-----------|
| 1 | Generalities | 7 |
| 1.1 | Scope of the documentation | 7 |
| 1.2 | Release management | 7 |
| 1.3 | Manufacturer identifier, product identification | 7 |
| 1.4 | Intended use | 8 |
| 1.5 | Abbreviations used | 8 |
| 1.6 | Norms | 8 |
| 1.6.1 | Applicable norms | 8 |
| 1.6.2 | Available certificates | 9 |
| 1.7 | Procedure for technical support | 9 |
| 1.8 | Copyright and Trademarks | 9 |
| 1.9 | Compliance | 10 |
| 1.10 | Limitation of liability | 11 |
| 2 | Safety..... | 12 |
| 2.1 | Safety pictograms definition | 12 |
| 2.2 | Serial label location | 13 |
| 2.3 | Hazards | 13 |
| 2.3.1 | Personnel | 14 |
| 2.3.2 | Material | 14 |
| 2.4 | Hygiene and sanitization | 14 |
| 2.4.1 | Sanitary issues | 14 |
| 2.4.2 | Hygiene measures | 15 |
| 3 | Description | 16 |
| 3.1 | Technical specifications..... | 16 |
| 3.2 | Performance flow rate characteristics | 18 |
| 3.3 | Outline drawing | 19 |
| 3.4 | Components description and location | 19 |
| 3.5 | Softener operating mode | 21 |
| 3.5.1 | Downflow regeneration cycle (5-cycles operation) | 21 |
| 3.5.2 | Filter operating mode (3-cycles operation) | 23 |
| 3.6 | Configurations for softener, no by pass and filter | 25 |
| 3.6.1 | Downflow softener | 25 |
| 3.6.2 | No by pass configuration | 25 |
| 3.6.3 | Filter | 27 |
| 4 | System sizing..... | 28 |
| 4.1 | Recommended Injector/DLFC/BLFC-Valve configuration..... | 28 |

| | | |
|----------|--|-----------|
| 4.2 | Sizing a softener (single unit) | 28 |
| 4.2.1 | Parameters to be considered | 28 |
| 4.2.2 | Determining the required volume of resin | 30 |
| 4.2.3 | Resin exchange capacity and capacity of the unit | 30 |
| 4.2.4 | Valve configuration | 33 |
| 4.2.5 | Cycle time calculation | 34 |
| 4.3 | Salt dosage definition | 37 |
| 4.4 | Injector flow rates | 37 |
| 4.4.1 | 1600 injectors | 37 |
| 4.4.2 | 1650 injectors | 38 |
| 4.4.3 | 1700/1710 injectors | 40 |
| 5 | Installation | 42 |
| 5.1 | Product identification | 42 |
| 5.2 | Warnings | 42 |
| 5.3 | Safety notices for installation | 43 |
| 5.4 | Installation environment | 43 |
| 5.4.1 | General | 43 |
| 5.4.2 | Water | 43 |
| 5.4.3 | Electrical | 44 |
| 5.4.4 | Mechanical | 44 |
| 5.5 | Integration constraints | 45 |
| 5.6 | Block diagram and configuration example | 46 |
| 5.7 | Valve on tank assembly | 47 |
| 5.8 | Valve connection to piping | 48 |
| 5.8.1 | Top-mounted valve installation | 48 |
| 5.8.2 | Side-mounted valve installation | 50 |
| 5.9 | Regeneration mode | 51 |
| 5.9.1 | Single valve (System 4) | 52 |
| 5.10 | Electrical connections | 52 |
| 5.11 | Bypassing | 54 |
| 5.12 | Drain line connection | 54 |
| 5.13 | Overflow line connection | 55 |
| 5.14 | Brine line connection | 56 |
| 6 | Programming | 57 |
| 6.1 | Display | 57 |
| 6.2 | Program structure and navigation | 58 |
| 6.2.1 | Parameter setting | 59 |
| 6.2.2 | USB menu structure | 60 |
| 6.2.3 | Quick Start-up menu structure and navigation | 62 |
| 6.2.4 | Home menu structure and navigation | 65 |
| 6.2.5 | Diagnostics menu structure and navigation | 67 |

| | | |
|----------|--|------------|
| 6.2.6 | Date/Time menu structure and navigation..... | 69 |
| 6.2.7 | Contact menu structure and navigation..... | 70 |
| 6.2.8 | Cycle menu structure and navigation..... | 71 |
| 6.2.9 | Settings menu structure and navigation..... | 72 |
| 6.2.10 | System menu structure and navigation..... | 74 |
| 6.2.11 | Regeneration menu structure and navigation..... | 76 |
| 6.3 | USB configuration and update..... | 78 |
| 6.4 | Quick Start-up setup..... | 80 |
| 6.4.1 | Quick Start-up mode programming chart..... | 80 |
| 6.4.2 | Language..... | 82 |
| 6.4.3 | Valve..... | 82 |
| 6.4.4 | Cycle type..... | 83 |
| 6.4.5 | Unit of measure..... | 83 |
| 6.4.6 | Capacity..... | 84 |
| 6.4.7 | Hardness..... | 85 |
| 6.4.8 | Salt dosage..... | 85 |
| 6.4.9 | Resin volume..... | 86 |
| 6.4.10 | Daylight savings..... | 86 |
| 6.4.11 | Date..... | 87 |
| 6.4.12 | Time..... | 87 |
| 6.4.13 | Quick Start-up completed..... | 88 |
| 6.5 | Home menu..... | 89 |
| 6.5.1 | Setting menu selection..... | 89 |
| 6.5.2 | Diagnostic menu..... | 90 |
| 6.5.3 | Date/Time setting menu..... | 96 |
| 6.5.4 | Contact setting menu..... | 99 |
| 6.5.5 | Cycle setting menu..... | 101 |
| 6.5.6 | Settings menu..... | 105 |
| 6.5.7 | System setting menu..... | 114 |
| 6.5.8 | Regeneration setting menu..... | 117 |
| 6.6 | Reset..... | 125 |
| 7 | Commissioning..... | 126 |
| 7.1 | Water filling, draining and waterproofness inspection..... | 126 |
| 7.1.1 | Activating a single valve system (System 4)..... | 126 |
| 7.2 | Sanitization..... | 127 |
| 7.2.1 | Disinfection of water softeners..... | 127 |
| 7.2.2 | Sodium or calcium hypochlorite..... | 127 |
| 8 | Operation..... | 129 |
| 8.1 | Display..... | 129 |
| 8.1.1 | During service..... | 129 |
| 8.1.2 | During regeneration..... | 130 |
| 8.2 | Recommendations..... | 130 |
| 8.3 | Manual regeneration..... | 130 |
| 8.3.1 | Manual regeneration menu structure and navigation..... | 131 |
| 8.3.2 | Trigger an immediate regeneration..... | 132 |

| | | |
|-----------|--|------------|
| 8.3.3 | Trigger a regeneration at next regeneration moment | 133 |
| 8.3.4 | Trigger a delayed regeneration | 133 |
| 8.3.5 | Trigger scheduled regeneration | 134 |
| 8.3.6 | To advance regeneration cycles | 135 |
| 8.4 | Operation during a power failure | 136 |
| 9 | Maintenance | 137 |
| 9.1 | General system inspection | 137 |
| 9.1.1 | Water quality | 137 |
| 9.1.2 | Mechanical checks | 137 |
| 9.1.3 | Regeneration test..... | 138 |
| 9.2 | Recommended maintenance plan | 139 |
| 9.2.1 | Valve used for softening..... | 139 |
| 9.2.2 | Valve used for filtration..... | 141 |
| 9.3 | Recommendations | 142 |
| 9.3.1 | Use original spare parts | 142 |
| 9.3.2 | Use original approved lubricants..... | 142 |
| 9.3.3 | Maintenance instructions | 142 |
| 9.4 | Cleaning and maintenance | 142 |
| 9.4.1 | First steps | 142 |
| 9.4.2 | Power head and/or motor assembly replacement | 143 |
| 9.4.3 | Controller replacement | 145 |
| 9.4.4 | Piston and/or seal and spacer kit replacement | 146 |
| 9.4.5 | Injector cleaning..... | 148 |
| 9.4.6 | BLFC cleaning | 149 |
| 9.4.7 | DLFC cleaning | 150 |
| 9.4.8 | Optical sensor replacement..... | 151 |
| 10 | Troubleshooting | 152 |
| 10.1 | Error detection | 152 |
| 10.2 | Controller | 152 |
| 10.3 | System..... | 154 |
| 11 | Spare parts and options..... | 156 |
| 11.1 | Valve parts list..... | 156 |
| 11.2 | Power head parts list | 159 |
| 11.3 | 1600,1700 Injector parts list | 161 |
| 11.3.1 | 1600/1650 injector parts list | 161 |
| 11.3.2 | 1700/1710 injector parts list | 163 |
| 11.4 | Brine valve parts list | 165 |
| 11.5 | Safety brine valves list | 167 |
| 11.6 | Safety brine valves parts list..... | 167 |
| 11.6.1 | Safety brine valves 2300 parts list | 168 |
| 11.6.2 | Safety brine valves 2310 parts list | 169 |
| 11.7 | Distribution systems parts list | 170 |

| | | |
|-----------|-----------------------------|------------|
| 11.8 | Air checks list..... | 170 |
| 11.9 | Meters parts list..... | 171 |
| 11.10 | Additional parts list..... | 172 |
| 11.11 | Other components list | 173 |
| 12 | Disposal..... | 174 |

1 Generalities

1.1 Scope of the documentation

The documentation provides the necessary information for appropriate use of the product. It informs the user to ensure efficient execution of the installation, operation or maintenance procedures.

The content of this document is based on the information available at the time of publication. The original version of the document was written in English.

For safety and environmental protection reasons, the safety instructions given in this documentation must be strictly followed.

The manufacturer reserves the right to make changes at any time without notice.

This manual is a reference and will not include every system installation situation. The person installing this equipment should have:

- training in the Fleck series, AiQ controllers and water treatment appliances installation;
- knowledge of water conditioning and how to determine proper controller settings;
- basic plumbing skills.

This document is available in other languages:

For Europe: <https://www.pentair.eu/product-finder/product-type/control-valves>.

For North America: <https://www.pentair.com/en-us/water-treatment-components/valves>.

1.2 Release management

| Revision | Date | Authors | Description |
|----------|------------|-------------|----------------|
| A | 31.10.2025 | AMI/EPL/EKG | First edition. |

1.3 Manufacturer identifier, product identification

| | Europe | North America |
|---------------------------|--|---|
| Manufacturer: | Pentair Manufacturing Italy S.R.L. Via Tiziano 32 20145 Milano (MI) Italy | Pentair Water Solutions 13845 Bishops Drive, Suite 200 Brookfield, WI 53005 United States |
| Assembled in the factory: | Pentair Manufacturing Italy Via Masaccio 13 Lugnano di Vicopisano 56010 (PI), Italy | Pentair Manufacturing Reynosa Av. de Los Nogales Lt. del 6 al 11 Nave 5 Parque Ind. Villa Florida Reynosa, Tamaulipas, 88730, Mexico |

Product identification: Fleck 2850 AiQ

1.4 Intended use

The device is intended for industry environment use only and it is purpose-built for water treatment.

1.5 Abbreviations used

| | |
|-------|----------------------------|
| Assy | Assembly |
| BLFC | Brine Line Flow Controller |
| BV | Brine Valve |
| CW | Cold Water |
| DF | Down Flow |
| DLFC | Drain Line Flow Controller |
| HW | Hot Water |
| Inj | Injector |
| NBP | No By Pass |
| PH | Power Head |
| QC | Quick Connect |
| Regen | Regeneration |
| S&S | Seals & Spacers |
| SBV | Safety Brine Valve |
| SM | Side Mounted |
| Std | Standard |
| TC | Time Clock |
| TM | Top Mounted |
| UF | Up Flow |

1.6 Norms

1.6.1 Applicable norms

Applicable norms for Europe

Comply with the following guidelines:

- 2014/35/UE: Low Voltage Directive;
- 2014/30/UE: Electromagnetic compatibility;
- 2011/65/UE: Restriction of use of certain hazardous substances in electrical and electronic equipment (RoHS);
- UNI EN ISO9001.

Meets the following technical standards:

- EN IEC 61010-1;
- EN IEC 61326-1.

Applicable norms for North America

Comply with the following guidelines:

- UL 979;
- NSF/ANSI/CAN Standard 61
- NSF/ANSI Standard 372
- CSA B483 1;
- FCC 47 CFR part 15 subpart b;
- ISED-ICES-003.

1.6.2 Available certificates

For Europe

- CE;
- DM174;
- ACS.

Please find beside the certifications for some of our product families. Please note that this list is not an exhaustive list of all our certifications. In case of need for more information please contact us.



For North America

- UL;
- WQA;
- FCC;
- ISED.

1.7 Procedure for technical support

Procedure to follow for any technical support request:

1. Collect the required information for a technical assistance request.
 - ⇒ Product identification [see Serial label location [→Page 13] and Recommendations [→Page 142]].
 - ⇒ Description of the device problem.
2. Please refer to the Troubleshooting [→Page 152]. If the problem persists contact your supplier.

Europe: techsupport.water@pentair.com

NAM: Phone: 1-800-279-9404

tech-support@pentair.com

1.8 Copyright and Trademarks

All indicated Pentair trademarks and logos are property of Pentair. Third party registered and unregistered trademarks and logos are the property of their respective owners.

© 2025 Pentair. All rights reserved.

1.9 Compliance

This device complies with Part 15 of the FCC rules and with Industry Canada licence-exempt RSS Standards. Operation is subject to the following two conditions;

1. This device may not cause harmful interference;
2. This device must accept any interference received, including interference that may cause undesired operation.

Contains FCC IC ID: 2AC7Z-ESPWR00M32

Contains FCC IC: 20198-ESPWR00M32

FCC Regulatory Notice - 47 CFR Part 15, Subpart C.

Instruction To User - This equipment has been tested and found to comply with the limits for a Class B digital device, pursuant to Part 15 of the FCC Rules. These limits are designed to provide reasonable protection against harmful interference in a residential installation. This equipment generates, uses and can radiate radio frequency energy and, if not installed and used in accordance with the instructions, may cause harmful interference to radio communications. However, there is no guarantee that interference will not occur in a particular installation. If this equipment does cause harmful interference to radio or television reception, which can be determined by turning the equipment off and on, the user is encouraged to try to correct the interference by one or more of the following measures:

- Reorient or relocate the receiving antenna.
- Increase the separation between the equipment and receiver.
- Connect the equipment into an outlet on a circuit different from that to which the receiver is connected.
- Consult the dealer or an experienced radio/TV technician for help.

Industry Canada (IC) Regulatory Notice – RSS210:

Instruction To User - This device complies with RSS210 of Industry Canada. (1999). Under Industry Canada regulations, this radio transmitter may only operate using an antenna of a type and maximum (or lesser) gain approved for the transmitter by Industry Canada. To reduce potential radio interference to other users, the antenna type and its gain should be so chosen that the equivalent isotropically radiated power (e.i.r.p.) is not more than that necessary for successful communication.

This device complies with Industry Canada licence-exempt RSS standard(s). Operation is subject to the following two conditions:

1. This device may not cause interference;
2. This device must accept any interference, including interference that may cause undesired operation of the device.

1.10 Limitation of liability

Pentair Water Treatment products benefit, under specific conditions, from a manufacturer warranty that may be invoked by Pentair's direct customers. Users should contact the vendor of this product for applicable conditions and in case of a potential warranty claim.

Any warranty provided by Pentair regarding the product will become invalid in case of:

- installation done by a non-water-professional;
- improper installation, improper programming, improper use, improper operation and/or maintenance leading to any kind of product damages;
- improper or unauthorized intervention on the controller or components;
- incorrect, improper or wrong connection/assembly of systems or products with this product and vice versa;
- use of a non-compatible lubricant, grease or chemicals of any type and not listed by the manufacturer as compatible for the product;
- failure due to wrong configuration and/or sizing.

Pentair accepts no liability for equipment installed by the user upstream or downstream of Pentair products, as well as for process/production processes which are installed and connected around or even related to the installation. Disturbances, failures, direct or indirect damages that are caused by such equipment or processes are also excluded from the warranty. Pentair shall not accept any liability for any loss or damage to profits, revenues, use, production, or contracts, or for any indirect, special or consequential loss or damage whatsoever. Please refer to the Pentair terms and conditions for more information about terms applicable to this product.

2 Safety

2.1 Safety pictograms definition

DANGER



This combination of symbol and keyword indicates an imminently hazardous situation that will result in serious or fatal injury if not avoided.

WARNING



This combination of symbol and keyword indicates a potentially hazardous situation that can result in serious or fatal injury if not avoided.

CAUTION



This combination of symbol and keyword indicates a potentially hazardous situation that can result in minimal or minor injury if not avoided.

Caution - material



This combination of symbol and keyword indicates a potentially hazardous situation that can result in material damage if not avoided.

Prohibition



Mandatory advice to follow.

Mandatory



Applicable guideline, measure.

Info



Informative comment.

2.2 Serial label location

Europe

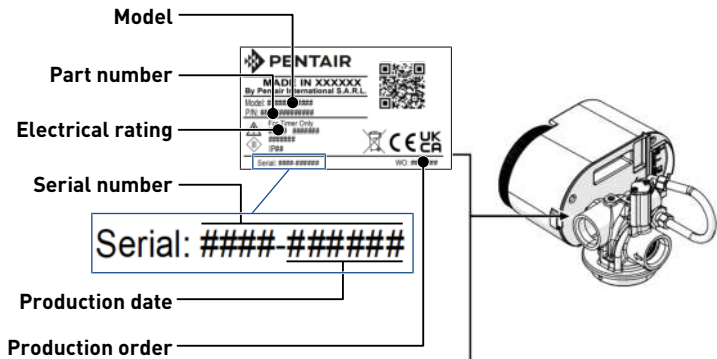

NAM

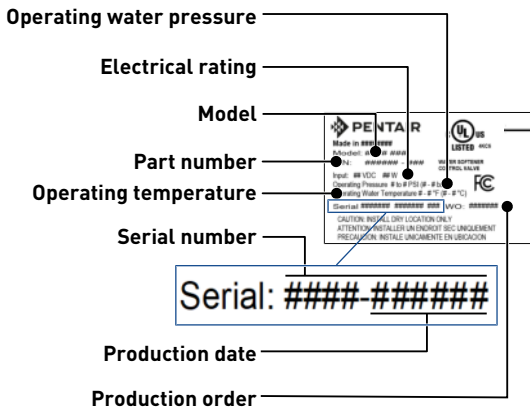

Mandatory



Ensure that the serial label and the safety labels on the device are completely legible and clean!

2.3 Hazards

All the safety and protection instructions contained in this document must be observed in order to avoid temporary or permanent injury, damage to property or environmental pollution.

At the same time, any other legal regulations, accident prevention and environmental protection measures, as well as any recognized technical regulations relating to appropriate and risk-free methods of working which apply in the country and place of use of the device must be adhered to.

Any non-observation of the safety and protection rules, as well as any existing legal and technical regulations, will result in a risk of temporary or permanent injury, damage to property or environmental pollution.

This product is not intended to be used for treating water that is microbiologically unsafe or of unknown quality without adequate disinfection before or after the product.

2.3.1 Personnel

CAUTION



Risk of injury due to improper handling!

Only qualified and professional personnel, based on their training, experience and instruction as well as their knowledge of the regulations, safety rules and operations performed, are authorized to carry out necessary work.

Mandatory



Any other maintenance operation must be carried out only by qualified and professional personnel!

2.3.2 Material

The following points must be observed to ensure proper operation of the system and the safety of user:

- be careful of high voltages present on the transformer (100 – 240 V; 50/60Hz);
- do not put your fingers in the system (risk of injuries with moving parts and shock due to electric voltage).

2.4 Hygiene and sanitization

2.4.1 Sanitary issues

Preliminary checks and storage

- Check the integrity of the packaging. Check that there is no damage and no signs of contact with liquid to make sure that no external contamination occurred;
- the packaging has a protective function and must be removed just before installation. For transportation and storage, appropriate measures should be adopted to prevent the contamination of materials or the objects themselves.

Assembly

- Assemble only with components which are in accordance with drinking water standards;
- after installation and before use, perform one or more manual regenerations in order to clean the media bed. During such operations, do not use the water for human consumption. Perform a disinfection of the system in the case of installations for treatment of drinking water for human use.

Info



This operation must be repeated in the case of ordinary and extraordinary maintenance.

It should also be repeated whenever the system remains idle for a significant time.

Info

**Valid only for Italy**

In case of equipment used in accordance with the DM25, apply all the signs and obligations arising from the DM25.

2.4.2 Hygiene measures

Disinfection

- The materials used for the construction of our products meet the standards for use with potable water; the manufacturing processes are also geared to preserving these criteria. However, the process of production, distribution, assembly and installation, may create conditions of bacterial proliferation, which may lead to odor problems and water contamination;
- it is therefore strongly recommended to sanitize the products. See Sanitization [[→Page 127](#)];
- maximum cleanliness is recommended during the assembly and installation;
- for disinfection, use Sodium or Calcium Hypochlorite and perform a manual regeneration.

3 Description

3.1 Technical specifications

Design specifications/ratings

| | |
|---|---|
| Valve body | Lead-free brass*** (NAM); Brass (EMEA) |
| Rubber components | EP or EPDM |
| Weight (valve with controller) | 10.2 lbs (4.6 kg) max |
| Recommended operating pressure | 26 - 125 psi (1.8 - 8.6 bar) (0.18 - 0.86 Mpa) |
| Maximum inlet pressure | 125 psi (8.6 bar) (0.86 Mpa) |
| Hydrostatic test pressure | 300 psi (20 bar) (2 Mpa) |
| Water temperature std | 34 - 110 °F (1 - 43 °C) |
| Water temperature for HW volumetric | 34 - 149° F (1 - 65 °C) only with mechanical or electronical stainless-steel meter |
| Water temperature for HW time clock | 34 - 181 °F (1 - 82 °C) |
| Ambient temperature | 41 - 120 °F (5 - 49 °C) |
| Regeneration flow | DF |
| Bypass of raw water during regeneration: | |
| Standard | Yes |
| NBP version | No |

*** As defined in the U.S. EPA Safe Drinking Water Act; the product also meets California Proposition 65 Standards for lead-free brass.

Flow rates (51 psi inlet (3.5 bar) (0.35 MPa) - valve only - top mount)

| | |
|--|-----------------------------------|
| Continuous service flow ($\Delta p = 15$ psi (1 bar) (0.1 MPa)) | 52 gpm (11.6 m ³ /h) |
| Peak service flow ($\Delta p = 25$ psi (1.8 bar) (0.18 Mpa)) | 66 gpm (15.0 m ³ /h) |
| Cv* | 13.2 gpm |
| Kv | 50.2 gpm (11.4 m ³ /h) |
| Maximum backwash flow ($\Delta p = 25$ psi (1.8 bar) (0.18 Mpa)) | 48.9 gpm (11.1 m ³ /h) |

*Cv: Flow rate in gpm across the valve at a pressure drop of 1 psi at 60 °F.

Valve connections

| | |
|--------------------------|---------------------|
| Tank top mounted adapter | 4" - 8 UN |
| Inlet/Outlet | 1½" NPTF/BSPF |
| Riser tube | 31/32" (50 mm) DN40 |
| Drain line | 1" NPT |
| Brine line (1600/1650) | ¾" |

Brine line (1700/1710) 1/2"

Electrical

| | |
|-------------------------------|---|
| Controller Operating Voltage* | 24 VDC (requires use of Pentair Water supplied transformer) |
| Input Supply Frequency | 50 or 60 Hz (controller configuration dependent) |
| Motor Input Voltage* | 24 VDC |
| Controller Power Consumption | 28.8 W |
| Protection rating | IP23** |
| Power supply | 100 to 240 VAC; 50/60 Hz |
| Transient overvoltages | within the limits of category II |
| Pollution Degree | 3 |

* Temporary overvoltage must be limited both in duration and frequency.

** See Installation environment [→Page 43] for correct installation.

Environmental conditions

- Install in dry location only;
- not exposed to the sun directly;
- temperature from 41 °F to 120 °F (5 °C to 49 °C);
- maximum relative humidity 80 % for temperatures up to 88 °F (31 °C) decreasing linearly to 50 % relative humidity at 104 °F (40 °C);
- mains supply voltage fluctuations up to ±10 % of the nominal voltage.

3.2 Performance flow rate characteristics

The graph shows the pressure drop created by the valve itself at different flow rates. It allows predetermining the maximum flow rate going through the valve depending on the system settings (inlet pressure etc). It also allows to determine the valve pressure drop at a given flow rate, and therefore to evaluate the system pressure drop vs flow rate.

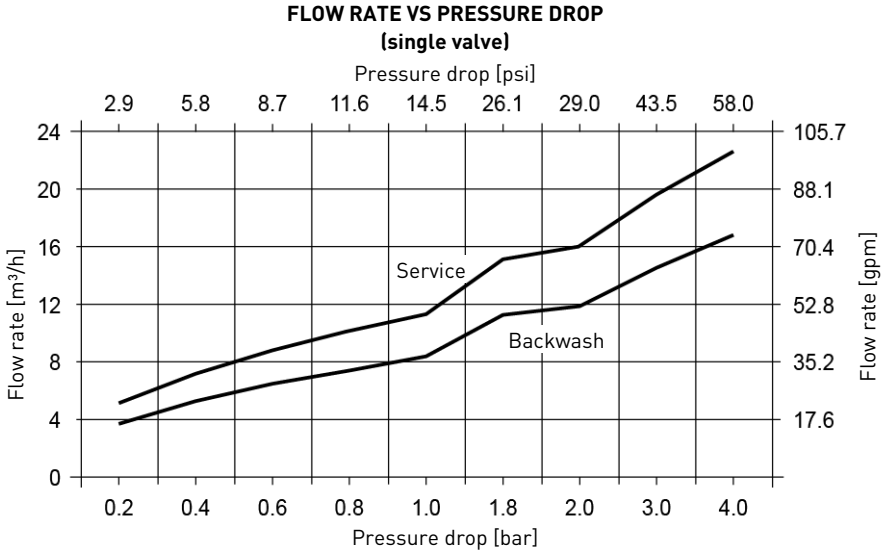

3.3 Outline drawing

Measurements: inch [mm]

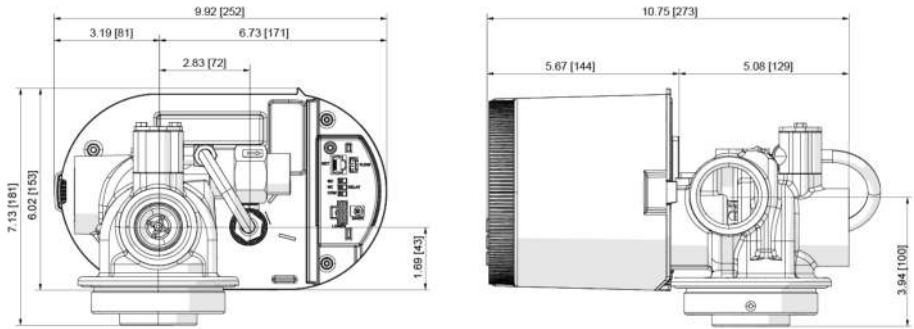

3.4 Components description and location

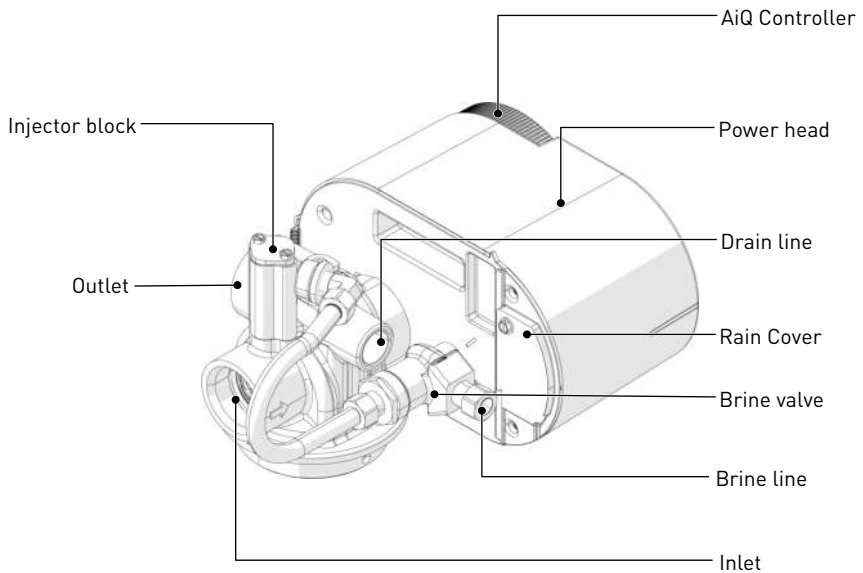

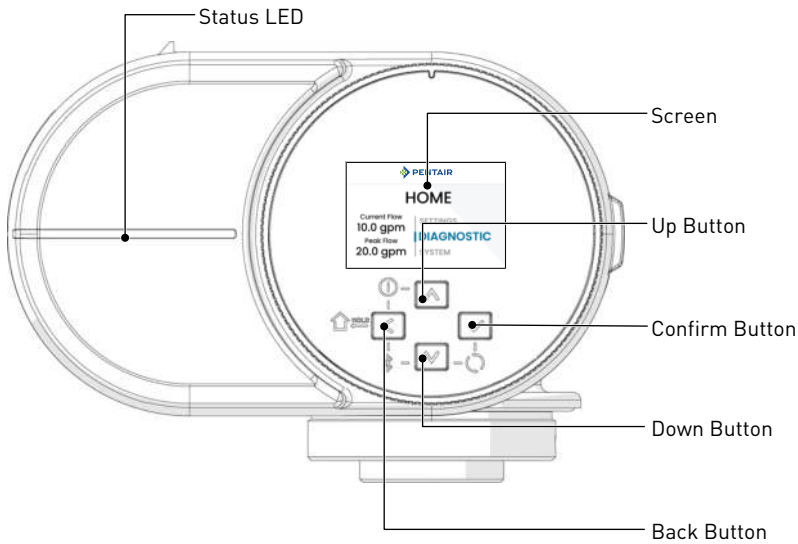
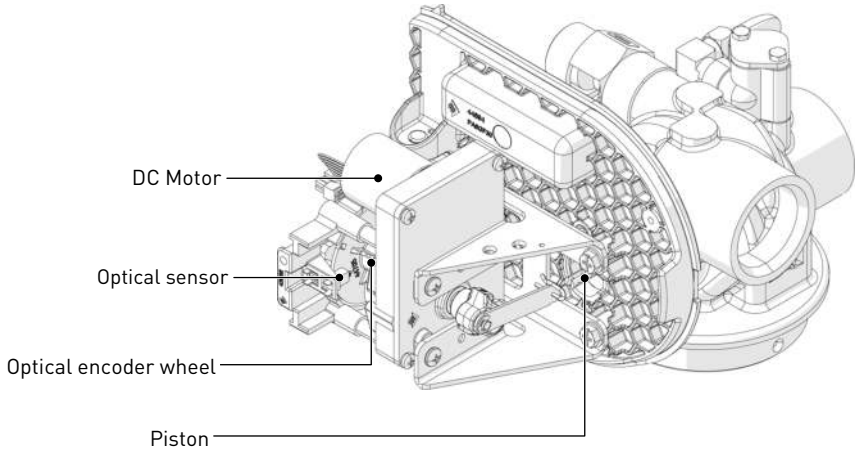

3.5 Softener operating mode

Info



This valve allows to do filtration and down flow regenerations.

3.5.1 Downflow regeneration cycle (5-cycles operation)

Service — Normal Use

Untreated water is directed down through the resin bed and up through the riser tube. The hardness ions attach themselves to the resin and are removed from the raw water being exchanged on the resin beads by sodium ions. The water is conditioned as it passes through the resin bed.

Backwash — Cycle C1

The flow of water is reversed by the valve and directed down the riser tube and up through the resin bed. During the backwash cycle, the bed is expanded and debris is flushed to the drain, while the media bed is remixed.

Brine draw & slow rinse — Cycles C2

The valve directs water through the brine injector and brine is drawn from the brine tank. The brine is then directed down through the resin bed and up through the riser tube to the drain. The hardness ions on the resin beads are replaced by sodium ions and are sent to the drain. The resin is regenerated during the brine cycle. When the air check valve closes, brine drawing finishes, and then the slow rinse phase starts.

Rapid rinse — Cycle C3

The valve directs water down through the resin bed and up through the riser tube to the drain. Any residual brine is rinsed from the resin bed, while the media bed is re-compacted.

Brine tank refill — Cycle C4

Water is directed to the brine tank, at a rate controlled by the refill controller [BLFC], to create brine for the next regeneration. During brine refill, treated water is already available at the valve outlet.

Pause & Delay — Cycle C5

The valve is in stand-by until the end of the cycle. In multiplex, if the brine tank is shared, this cycle allows to leave a brine preparation time.

Info



The cycle Pause & Delay is optional with AiQ controllers. The factory value is set to 0 minute.

Info



For illustration purpose only. Always verify inlet and outlet marking on the valve.

Downflow regeneration cycle (5-cycles operation)

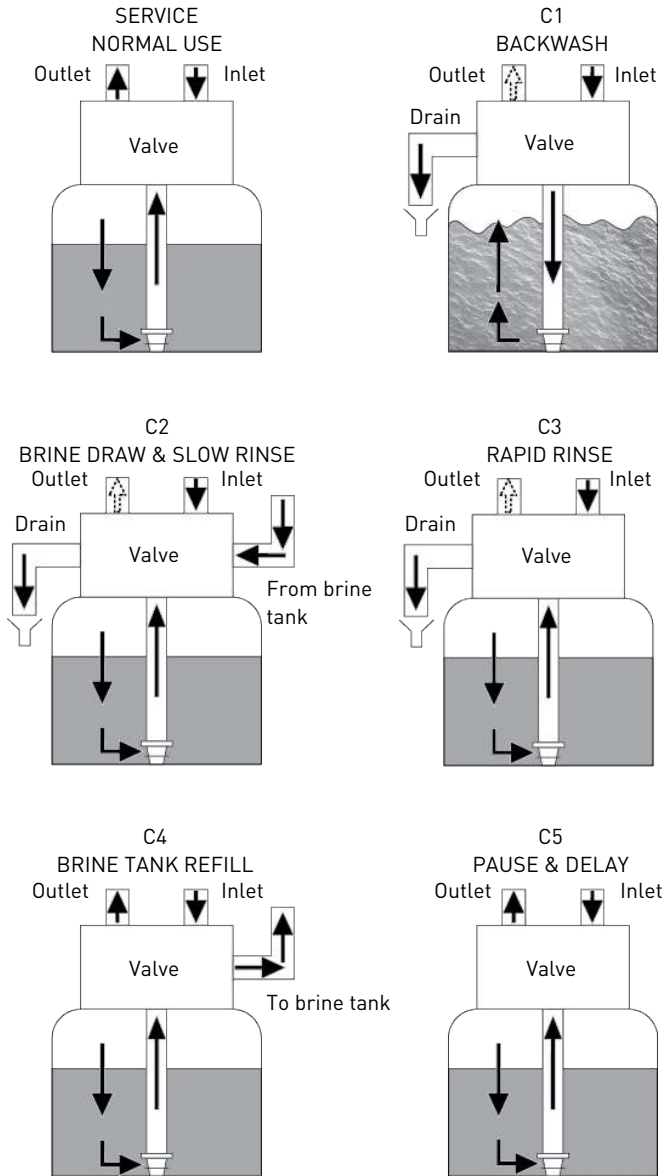

3.5.2 Filter operating mode (3-cycles operation)

Service — Normal Use

Untreated water is directed down through the filter media and up through the riser tube. The impurities are retained by the media. The water is filtered as it passes through the media.

Backwash — Cycle C1

The flow of water is reversed by the valve and directed down through the riser tube and up through the filter media. During the backwash cycle, the filter bed is expanded and debris is flushed to the drain, while the media bed is remixed.

Rapid rinse — Cycle C2

The valve directs water down through the filter media and up through the riser tube to the drain. The media bed is getting re-compacted.

Info



For illustration purpose only. Always verify inlet and outlet marking on the valve.

Filter operating mode (3-cycles operation)

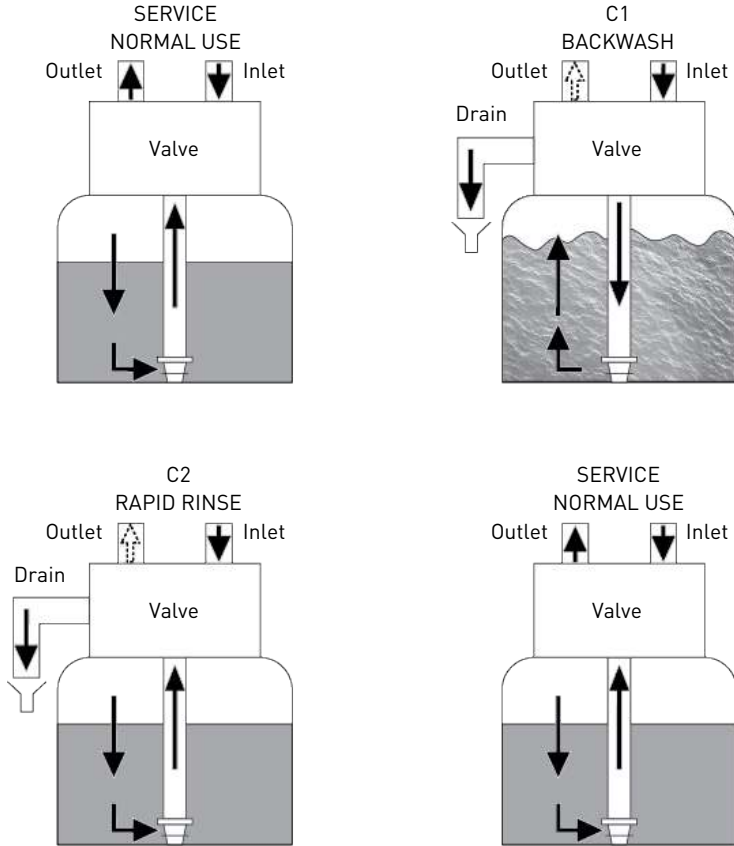

Untreated water, with WBP piston only

3.6 Configurations for softener, no by pass and filter

3.6.1 Downflow softener

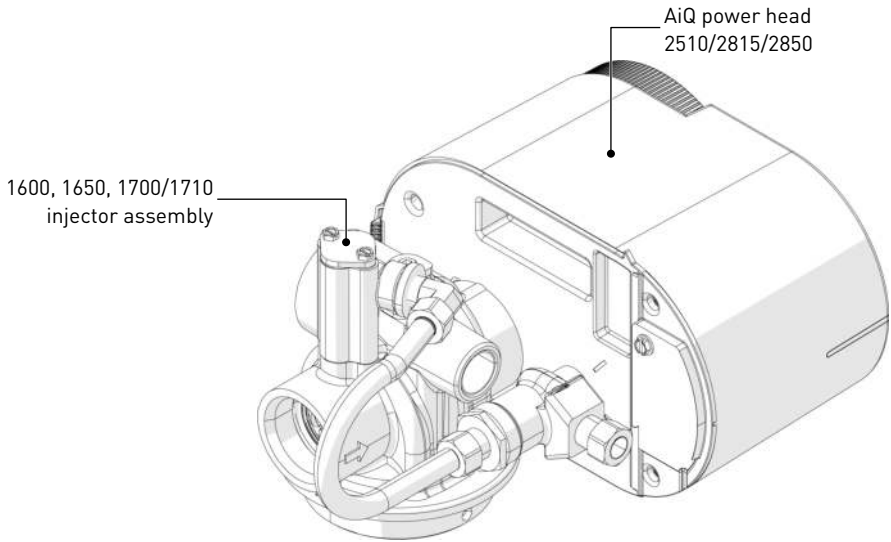

3.6.2 No by pass configuration

The valve is mounted with the AiQ power head 2510/2815/2850, part number PH2850AIQ-00 (EMEA); 62218 (NAM), a spacer, part number 19339 and a 1600,1650 or 1700/1710 injector assembly.

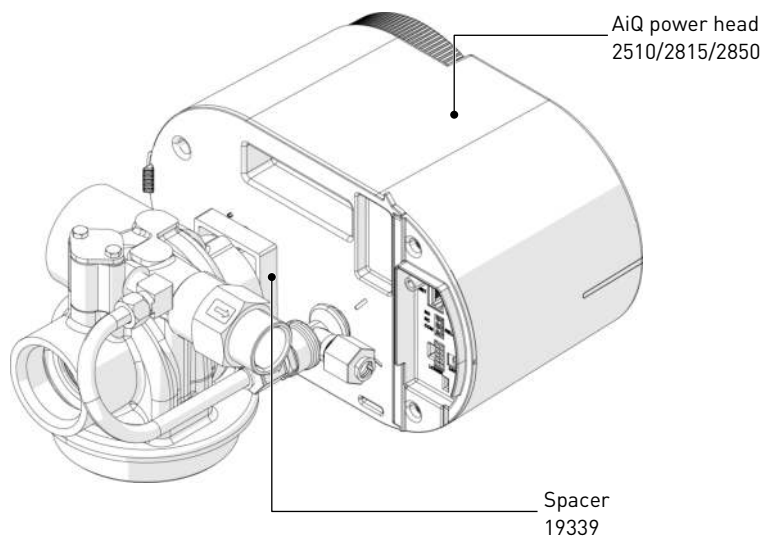

3.6.3 Filter

The valve is mounted with the AiQ power head 2510/2815/2850, part number PH2850AIQ-00(EMEA); 62218 (NAM) and a kit injector for filter customization 2850/2910, part number 29249.

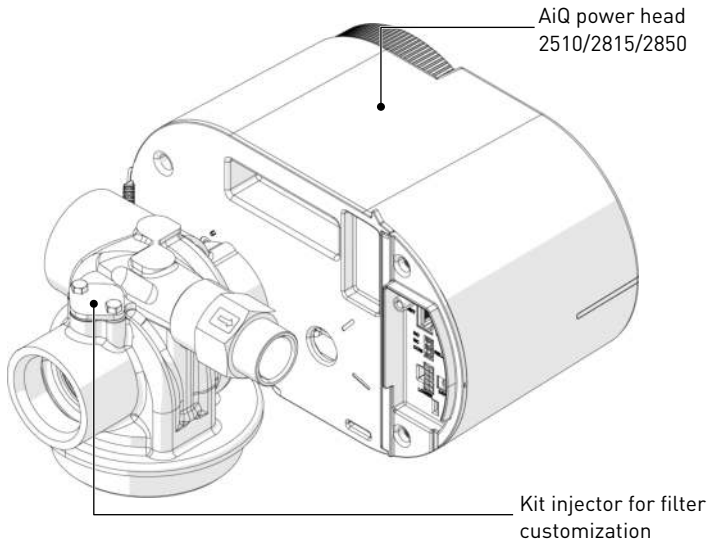

4 System sizing

4.1 Recommended Injector/DLFC/BLFC-Valve configuration

| Brine syst. | Tank Diameter | Resin volume L | Injector | | | | DLFC | BLFC | |
|------------------------|---------------|-------------------|----------|--------|-----|-------|-------|----------|----------|
| | [in] | | DF | Color | UF | Color | [gpm] | DF [gpm] | UF [gpm] |
| 2850/ 1600/ 1650 | 10 | 35 – 42 | 1 | White | N/A | N/A | 2.4 | 0.50 | N/A |
| | 12 | 43 – 56 | 2 | Blue | | | 3.5 | | |
| | 14 | 57 - 85 | 3 | Yellow | | | 5.0 | 1.0 | |
| 2850/ 1700/ 1710 | 16 | 86 – 113 | 3C | Green | | | 7.0 | 1.2 | |
| | 21 | 114 - 198 | 4C | | | | 10 | 2.0 | |
| | 24 | 199 - 293 | | | | | 15.0 | | |
| | 30 | 284 - 425 | 5C | | | | White | 25.0 | |

4.2 Sizing a softener (single unit)

4.2.1 Parameters to be considered

Whenever installing a softener, it is preferable to have full water analysis to ensure the inlet water content will not affect the resin bed.

Tip



Please consult your resin manufacturer specification!

To ensure that no additional pretreatment prior to softening is required.

The below sizing method can be applied for both residential and industrial softeners.

The sizing of a softener must be based upon certain parameters:

- inlet water hardness;
- peak flow rate and nominal flow rate;
- service velocity;
- salt dosage.

The softening and regeneration reactions are driven under certain conditions. To allow these reactions to take place, make sure that the velocity is convenient during the different phases for proper ion exchange. This velocity is given in the resin manufacturer specifications sheet.

Depending on the inlet water hardness, the service velocity for standard softening must be between:

| Service velocity [bed volume per hour] | Inlet water hardness [mg/l as CaCO ₃] | °TH | °dH |
|---|--|---------|-------------|
| 8 - 40 | <350 | <35 | <19.6 |
| 8 - 30 | 350 to 450 | 35 - 45 | 19.6 - 25.2 |
| 8 - 20 | >450 | >45 | >25.2 |

Caution - material

Risk of leakage due to unrespected service velocity !

Failure to respect the service velocity will lead to hardness leakage or even total softener inefficiency.

Note that the water supply piping size may also be useful when estimating the nominal flow rate, since the size of the piping allows a maximum flow rate to pass. Assuming the maximum velocity of water in pipes is about 9.84 ft/s (3 m/s), a good estimation for most common pressure 43.51 Psi (3 bar) (0.3 Mpa) and temperature 60.8°F (16°C) is:

| Piping size (internal diameter) | | Max. flow rate | |
|---------------------------------|------|--------------------|------------------------------|
| [in] | [mm] | [gpm at 9.84 ft/s] | [m ³ /h at 3 m/s] |
| 0.5 | 12 | 5.37 | 1.22 |
| 0.75 | 20 | 14.93 | 3.39 |
| 1 | 25 | 25.23 | 5.73 |
| 1.25 | 32 | 38.26 | 8.69 |
| 1.5 | 40 | 59.75 | 13.57 |
| 2.0 | 50 | 93.34 | 21.20 |
| 2.5 | 63 | 150.58 | 34.2 |
| 3.0 | 75 | 216.62 | 49.2 |

4.2.2 Determining the required volume of resin

When sizing a softener, make sure that the volume of resin in the tank (bed volume) will be sufficient so that even when the peak flow rate is reached, the velocity is still between the above values depending on the hardness. When sizing a softener, always choose the resin volume and tank size based on the peak flow rate but not on the nominal flow rate.

Caution - material



Risk of leakage due to wrong sizing !

Sizing on the nominal flow rate without taking the peak flow rate into account would result in choosing smaller tank size and resin volume, and may lead in severe hardness leakage during the service cycle when the peak flow is reached.

The maximum softened water flow rate that a softener can produce is given by the following formula:

$$Q_{\text{service max}} = F_{\text{service}} \times BV$$

with:

$Q_{\text{service max}}$: service flow rate [gpm] [(l/min)]

F_{service} : service velocity [BV/h]

BV: bed volume of resin [ft³] [(l)]

Knowing this required volume of resin, it is possible now to determine the needed tank. Note that at least a third of the total volume of the tank must be kept as free space so that the bed expansion during backwash is sufficient to ensure correct cleaning of the resin.

4.2.3 Resin exchange capacity and capacity of the unit

The resin exchange capacity and capacity of the unit are two different things that should not be confused. The resin exchange capacity is the amount of Ca²⁺ and Mg²⁺ that can be retained by 1/28 ft³ (1 litre) of resin, which will depend on the resin type and salt dosage, whereas the capacity of the unit is the capacity of the system, which will depend on the volume of resin and resin exchange capacity.

Knowing the required volume of resin, it is possible to determine the exchange capacity of the unit. The capacity of the unit can be expressed in different ways:

- the mass capacity, which corresponds to the weight in equivalent CaCO₃ that can be fixed on the resin, expressed in Grain (or gram) as CaCO₃;
- the volume capacity, which represents the maximum amount of water that can be treated between two regenerations. This last capacity takes into account the hardness of the water to be treated and is expressed in ft³ (m³ or litre);
- the combined capacity, which represents the volume of water that could be treated between two regenerations if the inlet hardness is 1 GPG (°f or °dH). This capacity is expressed in GPG "grains per gallon" (°f.m³ or °dH.m³).

The resin exchange capacity will depend on the amount of salt to be injected into the resin bed during the regeneration. This amount of salt is given in grams per litre of resin. The next table is showing the resin exchange capacity in function of the amount of salt for a system with standard efficiency regeneration.

Resin exchange capacity as a function of the salt dosage:

| Salt amount [g/L _{resin}] | Corresponding resin exchange capacity [g/L _{resin}] as CaCO ₃ | °f.m ³ [per L _{resin}] | °dH.m ³ [per L _{resin}] |
|--|--|--|---|
| 50 | 29.9 | 2.99 | 1.67 |
| 60 | 34 | 3.4 | 1.9 |
| 70 | 37.5 | 3.75 | 2.09 |
| 80 | 40.6 | 4.06 | 2.27 |
| 90 | 43.4 | 4.34 | 2.42 |
| 100 | 45.9 | 4.59 | 2.56 |
| 110 | 48.2 | 4.82 | 2.69 |
| 120 | 50.2 | 5.02 | 2.8 |
| 130 | 52.1 | 5.21 | 2.91 |
| 140 | 53.8 | 5.38 | 3.01 |
| 150 | 55.5 | 5.55 | 3.1 |
| 170 | 58.5 | 5.85 | 3.27 |
| 200 | 62.7 | 6.27 | 3.5 |
| 230 | 66.9 | 6.69 | 3.74 |
| 260 | 71 | 7.1 | 3.97 |
| 290 | 75.3 | 7.53 | 4.21 |

To calculate the system mass capacity:

$$M_{\text{capacity}} = V_{\text{resin}} \times C_{\text{resin ex}}$$

with:

 M_{capacity} : system mass capacity
[lb as CaCO₃] ([g as CaCO₃])

 V_{resin} : volume of resin [ft³] ([L])

 $C_{\text{resin ex}}$: resin exchange capacity
[lb/ft³ as CaCO₃] ([g/L_{resin} as CaCO₃])

To calculate the system combined capacity:

$$C_{\text{capacity}} = V_{\text{resin}} \times C_{\text{cor resin ex}}$$

with:

 C_{capacity} : system combined capacity
[grain] ([°f.m³ or °dH.m³])

 V_{resin} : volume of resin [ft³] ([L])

 $C_{\text{cor resin ex}}$: corresponding resin exchange capacity
[grain/ft³] ([°f.m³/l or °dH.m³/l])

To calculate the system volume capacity:

$$V_{\text{capacity}} = M_{\text{capacity}} / TH_{\text{inlet}}$$

Or

$$V_{\text{capacity}} = C_{\text{capacity}} / TH_{\text{inlet}}$$

with:

V_{capacity} : system volume capacity
[gal] ([m³])

M_{capacity} : system mass capacity
[grain as CaCO₃] ([gram as CaCO₃])

C_{capacity} : system combined capacity
[grain] ([°f.m³ or °dH.m³])

TH_{inlet} : inlet water hardness
[GPG as CaCO₃] ([mg/L as CaCO₃ or °f or °dH])

Mandatory

If a mixing device is set on the valve before meter, use $TH = TH_{\text{INLET}} - TH_{\text{OUTLET}}$!

Having determined the previous capacity allows the operator to know the service cycle duration.

4.2.4 Valve configuration

Knowing the volume of resin, tank size and specifications of the resin, it is possible to determine the required valve configuration. The resin specification will give the backwash velocity, as well as the brine draw and slow rinse velocity that must be respected in order to ensure a proper regeneration of the unit. From this data, determine the required backwash flow rate as well as the brine draw and slow rinse flow rate. In most cases, the fast rinse flow rate will be the same as the backwash flow rate, however for certain valve types the fast rinse flow rate will be the same as the service flow rate.

To determine the backwash flow rate:

$$Q_{\text{backwash}} = F_{S_{\text{backwash}}} \times S$$

with:

Q_{backwash} : backwash flow rate
[ft³/h] [(m³/h)]

$F_{S_{\text{backwash}}}$: backwash velocity
[ft/h] [(m/h)]

S: Tank cross section area
[ft²] [(m²)]

The DLFC installed on the valve has to limit the backwash flow rate to the above calculated flow rate.

To determine the injector size:

The velocities to be respected for brine draw and slow rinse are given on the resin manufacturer specifications. Generally speaking, the injector must allow a flow rate of about 4BV / h (corresponding to the flow rate of brine being drawn added to the flow rate of raw water passing through the injector nozzle to create the suction effect).

$$Q_{\text{inj}} = 4 \times \text{BV} / \text{h}$$

with:

Q_{inj} : total flow rate passing through the injector
[ft³/h] [(L/h)]

BV: bed volume of resin [ft³] [(L)]

Info



This value does not correspond to the brine draw flow rate but to the total flow rate passing through the injector.

Refer to the injector diagrams at the inlet pressure in order to check if the injector will give a correct flow rate.

See chapters Salt dosage definition [→Page 37] and Injector flow rates [→Page 37].

4.2.5 Cycle time calculation

From this point, the volume of resin, the tank size, the capacity of the softener and the valve configuration are determined. Next step is to calculate the regeneration cycle duration, which depends on the valve configuration and the resin specifications.

Info



Several parameters need, potentially, to be adjusted.

For cycle time calculation the valve configuration must be known, which depends on:

- the tank size;
- the resin specifications for the velocity for backwashing the resin bed;
- the velocity of water for brine draw, slow rinse and fast rinse.

Further information needed for cycle time calculation are:

- the resin volume previously determined;
- the salt amount used per regeneration;
- the volume of water to use for backwash, brine draw, slow rinse, and fast rinse.

To calculate the backwash duration:

$$T_{\text{backwash}} = (N_{\text{Bvw}} \times BV) / Q_{\text{DLFC}}$$

with:

T_{backwash} : backwash duration [min]

N_{Bvw} : number of bed volume for backwash

BV: bed volume [ft³] [(L)]

Q_{DLFC} : drain line flow controller size
[ft³/min] [(L/min)]

Info



The typical value of the volume of water to be used for backwash is between 1.5 and 4 times the bed volume, depending on the inlet water quality.

To calculate the brine draw duration:

Knowing the injector draw flow rate at the working pressure:

$$T_{\text{brine draw}} = V_{\text{brine}} / Q_{\text{draw}}$$

with:

$T_{\text{brine draw}}$: brine draw duration [min]

V_{brine} : brine volume to be drawn [ft³] [(L)], see Refill Calculation [→Page 35].

Q_{draw} : injection draw flow rate
[ft³/min] [(L/min)]

Tip



Multiply the amount of salt in lb (kg) by 3 to get an approximation of the brine volume to draw!

To calculate slow rinse duration:

The volume of water to be used for slow rinse is given in the resin manufacturers specifications. Generally speaking, it is advised that between 2 and 4 BV of water is used to perform the slow rinse after brine draw. The slow rinse cycle allows brine to be pushed slowly through the resin bed, allowing the resin to be in contact with brine for sufficient time and therefore to be regenerated.

Refer to the injector curve at the common working pressure to determine the slow rinse duration.

$$T_{\text{slow rinse}} = (N_{\text{BVsr}} \times \text{BV}) / Q_{\text{SR}}$$

with:

$T_{\text{slow rinse}}$: slow rinse duration [min]

N_{BVsr} : number of bed volume for slow rinse

BV: bed volume [ft³] ([L])

Q_{SR} : injector slow rinse flow rate
[ft³/min] ([L/min])

To calculate fast rinse duration:

The fast rinse is aimed at eliminating an excess of salt in the resin bed and also recompacting the resin in the tank.

Depending on the valve type, the fast rinse flow rate is controlled by the DLFC or it has about the same flow rate as in service. The fast rinse velocity can be the same as the service velocity, and the volume of water to be used for the fast rinse is generally between 1 and 10 BV depending on the salt dosage.

$$T_{\text{fast rinse}} = (N_{\text{BVfr}} \times \text{BV}) / Q_{\text{DLFC}}$$

with:

$T_{\text{fast rinse}}$: fast rinse duration [min]

N_{BVfr} : number of bed volume for fast rinse

BV: bed volume [ft³] ([L])

Q_{DLFC} : drain line flow controller size
[ft³/min] ([L/min])

To calculate the refill duration:

The refill flow rate is controlled by the refill controller (BLFC). The relation between the BLFC size, the tank size and the resin volume is given in the valve specifications.

To calculate the refill duration:

$$T_{\text{refill}} = V_{\text{WB}} / Q_{\text{BLFC}}$$

with:

T_{refill} : refill duration [min]

V_{WB} : Volume of water to be refill to prepare the brine
[ft³] ([L])

Q_{BLFC} : BLFC size
[ft³/min] ([L/min])

$$V_{WB} = D_{Salt} \times BV / S_{sol}$$

with:

V_{WB} : Volume of water to be refill to prepare the brine
[ft³] ([L])

D_{Salt} : Salt dosage per litre of resin
[lb/ft³] ([g/L])

BV: Bed volume [ft³] ([L])

S_{sol} : 0.79lb/ft³ (360g/L) - Solubility of salt per litre of water

Tip



When calculating the time required to draw the brine, take into account that the volume of brine [Vbrine] will be 1.125 bigger than the volume of water refilled!

4.3 Salt dosage definition

The salt settings are controlled through the controller programming. See Resin exchange capacity and capacity of the unit [→Page 30].

4.4 Injector flow rates

The following graphics represent the injectors flow rate as a function of the inlet pressure for the different injector sizes.

4.4.1 1600 injectors

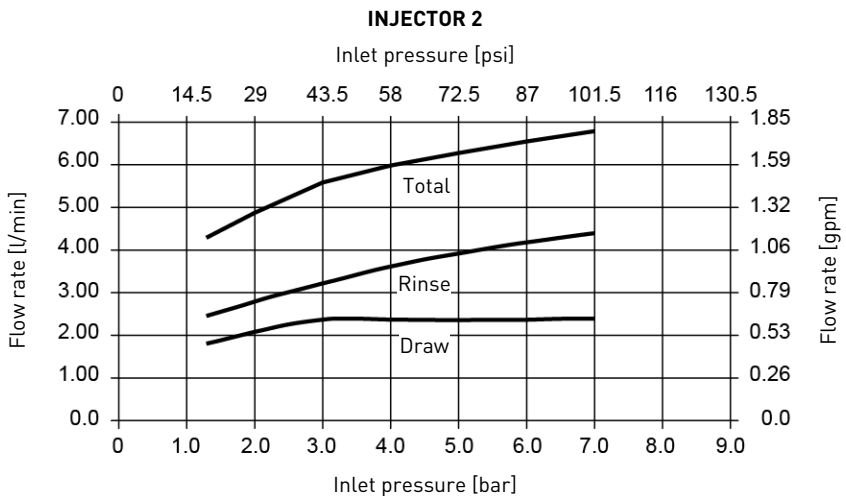
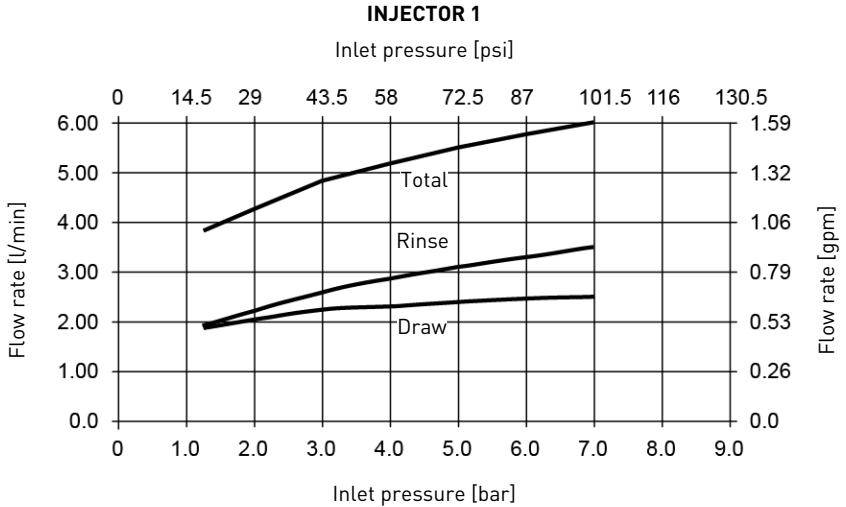

INJECTOR 3

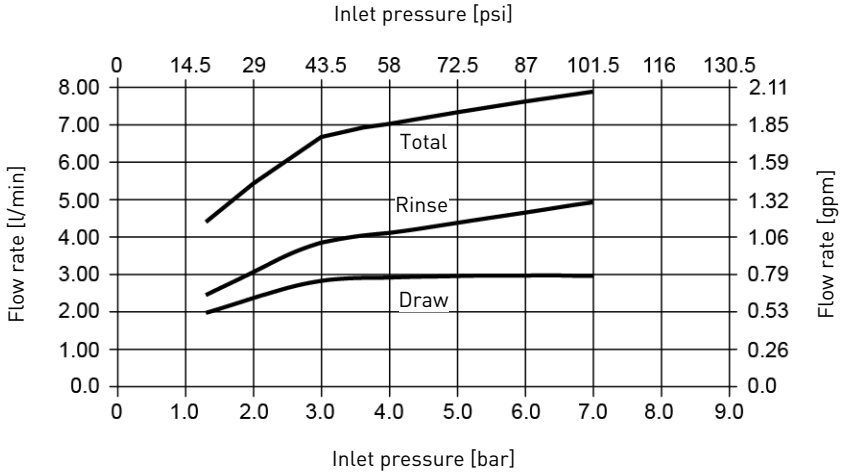

4.4.2 1650 injectors

INJECTOR 1

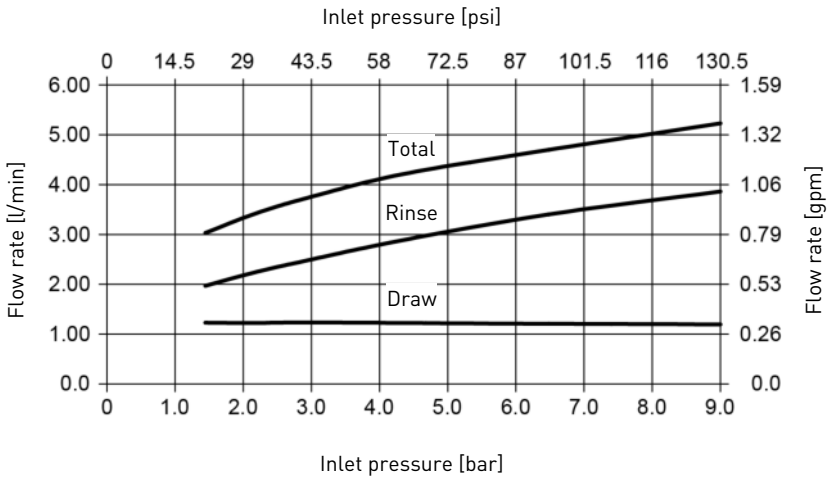

INJECTOR 2

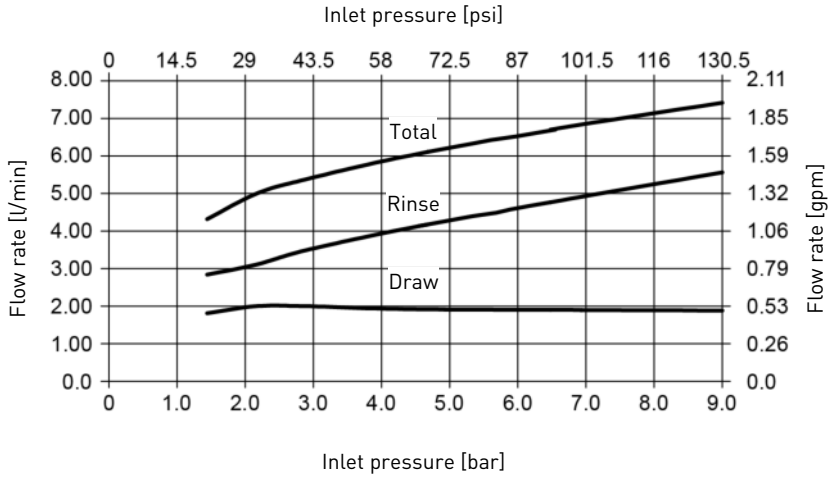

INJECTOR 3

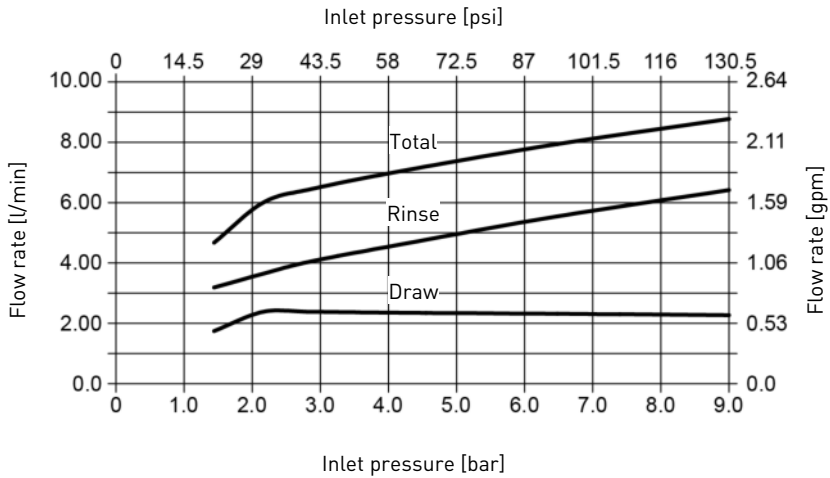

4.4.3 1700/1710 injectors

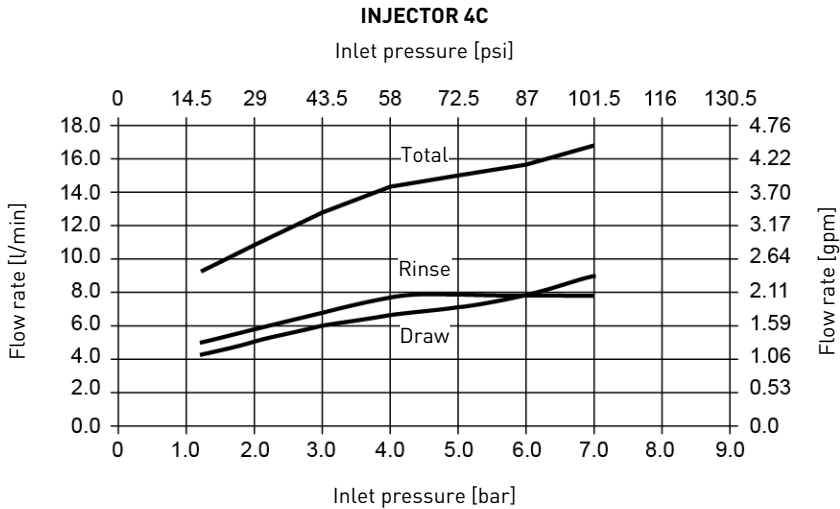
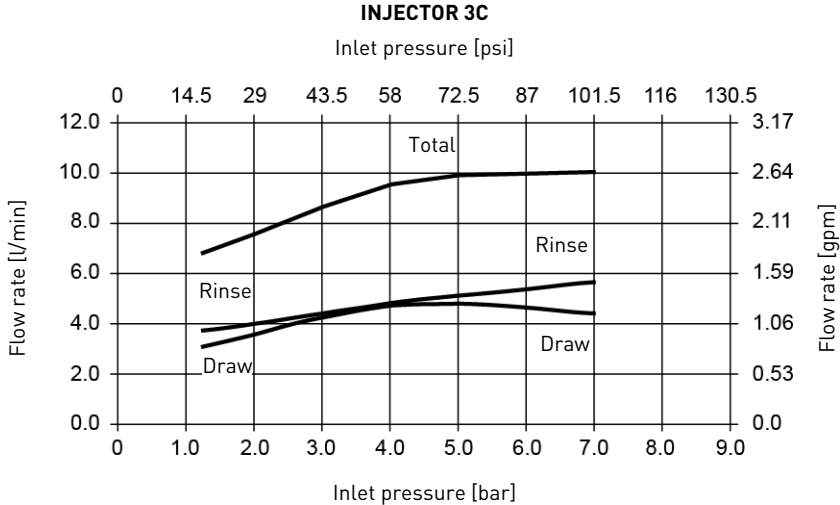

INJECTOR 5C

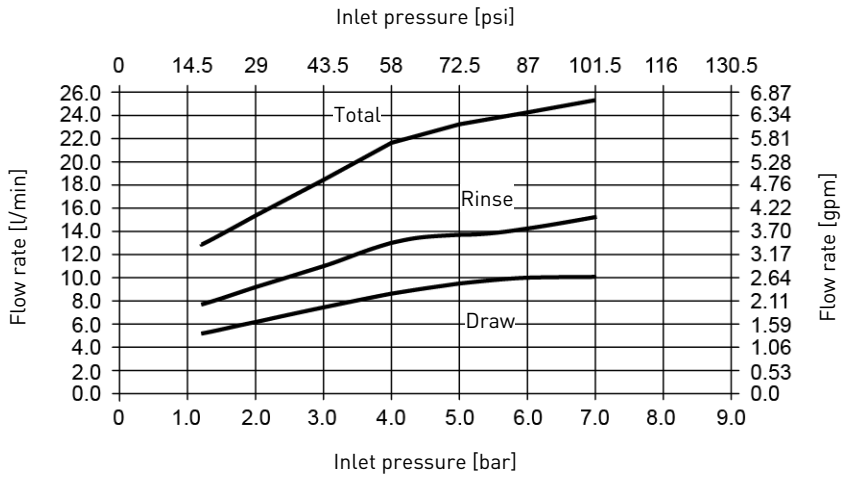

5 Installation

⚠ CAUTION



Risk of injury due to electrical shock or pressurized elements !

It is strictly forbidden for not qualified personal, to accede to system’s internal parts to perform any kind of technical action.

Be sure to disconnect the electrical power, close the water inlet and depressurize the system before opening the front cover to access internal parts !

5.1 Product identification

Info



The 2850 AiQ product is sold in several configurations; It is important to identify your configuration before proceeding with installing the product.

First check whether the product is already equipped with a power supply or not; if it is not present, the product must be powered with the following characteristics:

| | | | |
|--------------------------|--|--------------------------|------|
| Output current frequency | 50/60 Hz | Minimum power absorption | 29 W |
| Output current voltage | 24 VDC | Insulation Class | II |
| Connector Type | DC plug type: 5.5*2.5*9.5 mm (7/32" * 3/32" * 3/8") | | |

The input characteristics of the power supply depend on the electrical network available on site.

⚠ DANGER



The choice of a correct power supply is mandatory to guarantee the safety of users, if you do not feel expert, consult a professional.

The power supplies that Pentair supplies with the product are different and can be recognized by the part number on the power supply data plate; and these are:

| Part number | Type | Plug type | Input electrical rating |
|-------------|---|-----------|-------------------------|
| 44800-01 | Australian Transformer | Type I | 240 VAC; 50/60 Hz |
| 44800 | North American Transformer / Japanese Transformer | Type A | 100-240 VAC; 50/60 Hz |
| 44801 | European Transformer | Type C | 100-240 VAC; 50/60 Hz |

Mandatory



Always check first if the supplied transformer is compatible with the local electrical network!

5.2 Warnings

The manufacturer will not be held liable for any damages to people or properties resulting from an improper use of the device not compliant with the following instructions.

Whenever this guide doesn't clarify all doubts about installation, service, or maintenance, please contact the technical support of the company that has installed the device.

Device installation must be done by a qualified technician according to the current standards and regulations, using tools compliant with a device for safe use and referring to that technician also for device maintenance.

In case of out of order or malfunction, before performing any kind of action on the device, please ensure that you have disconnected the transformer from the power source, shut off the inlet water supply to the valve and drained water pressure by opening a tap down-line of the valve.

1. Be careful when removing the valve from the box and during subsequent handling, weight is liable to cause damage to property and persons in case of accidental impact.
2. Before sending the water on the valve, make sure that all plumbing connections are tight and properly implemented in order to avoid dangerous leaks of pressurized water.
3. Use caution when installing welded metal piping near the valve, the heat may damage the plastic body of the valve and the bypass.
4. Be careful not to let the full weight of the valve rest on fittings, pipes, or bypass.
5. Make sure that the environment in which the valve is installed does not reach freezing temperatures of the water, the valve may be damaged.
6. Make sure that the tank containing the resin is vertical; otherwise, the resin could enter the valve and damage it.

5.3 Safety notices for installation

- Observe all warnings that appear in this manual;
- only qualified and professional personnel are authorized to carry out installation work.

5.4 Installation environment

5.4.1 General

- use only regenerant salts designed for water softening. Do not use ice melt, block, or rock salts;
- keep the media tank in an upright position. Do not turn on its side, upside down, or drop it. Turning the tank upside down may cause media to enter the valve or might clog the upper screen;
- follow State and local codes for water testing. Do not use water that is micro-biologically unsafe or of unknown quality;
- when filling the media tank with water, first place the valve in the backwash position, then partly open the manual valve. Fill the tank slowly to prevent media from exiting the tank;
- when installing the water connection (bypass or manifold), first connect to the plumbing system. Allow heated parts to cool and cemented parts to set before installing any plastic parts. Do not get primer or solvent on O-rings, nuts, or the valve.

5.4.2 Water

- Water temperature must not exceed 109.4 °F (43 °C) for standard version, 149 °F (65°C) for volumetric hot water version and 179 °F (82 °C) for time clock hot water version;

- a minimum of 26 psi (1.8 bar) (0.18 MPa) of water pressure is required for the valve to operate effectively.

Mandatory



Do not exceed a maximum of 125 psi inlet pressure (8.6 bar) (0.86 MPa). In such cases, it is necessary to install a pressure regulator upstream the system.

5.4.3 Electrical

There are no user-serviceable parts in the AC/DC transformer, motor, or controller. In the event of a failure, these should be replaced.

- all electrical connections must be completed according to local codes;
- use only the power AC/DC transformer that is supplied;

Mandatory



The use of any power transformer other than the one supplied void the warranty of all electronic parts of the valve!

- to disconnect power, unplug the AC/DC transformer from its power source;
- an uninterrupted current supply is required. Please make sure that the voltage supply is compatible with the unit before installation;
- make sure the controller power source is plugged in;
- if the electrical cable is damaged, it is imperative that it is replaced by qualified personnel.

5.4.4 Mechanical

Mandatory



Place the rain cover over the back connection port and tighten the screw provided.

The IP23 insulation level is not maintained if the rain cover is incorrectly installed; the protection level will drop to IP20.

Mandatory



Secure the cover to the back plate using the screw provided.

In the event of violent external impacts, the integrity of the housing cannot be guaranteed if it is incorrectly assembled.

Caution - material



Risk of damage due to wrong lubricant use

Do not use petroleum-based lubricants such as Vaseline, oils, or hydrocarbon-based lubricants.

Use only approved silicone grease or soapy water!

- all plastic connections should be hand-tightened. PTFE (plumber's tape) may be used on connections that do not use an O-ring seal. Do not use pliers or pipe wrenches;
- existing plumbing should be in a good shape and free from limescale. In case of doubt, it is preferable to replace it;

- all plumbing must be completed according to local codes and installed without tension or bending stresses;
- soldering near the drain line should be done before connecting the drain line to the valve. Excessive heat will cause interior damage to the valve;
- do not use lead-based solder for sweat solder connections;
- the riser tube should be cut flush with the top of the tank. Slightly bevel the ridge in order to avoid deterioration of the seal whilst fitting the valve;
- the drain line must be a minimum of ½" (12.7 mm) in diameter. Use ¾" (19 mm) pipe if the backwash flow rate is greater than 7 gpm (26.5 Lpm) or the pipe length is greater than 236.2" (6 m);
- do not support the weight of the system on the valve fittings, plumbing, or the bypass;
- it is not recommended to use sealants on the threads. Use PTFE (plumber's tape) on the threads of the drain elbow, and other NPT/BSP threads;
- the installation of a pre-filter is always recommended (100µ nominal);
- valve inlet/outlet must be connected to main piping via flexible.

5.5 Integration constraints

Location of a water treatment system is important. The following conditions are required.

CAUTION



The surface for installation (platform or floor) must be solid, flat and level.

Mandatory



Drain must be capable of handling a backwash flow rate of 5 gpm (19 l/min).

- locate the softener as close as possible from drain discharge point and within 40 ft (12.2 m) maximum of drain discharge point, respecting minimum drain line diameter advises given at chapter Drain line connection [→Page 54];
- room to access equipment for maintenance and adding brine (salt) to tank;
- constant electrical supply to operate the controller;
- local drain for discharge as close as possible;
- water line connections with shut off or bypass valves;
- must meet any local and state codes for site of installation;
- valve is designed for minor plumbing misalignments. Do not support weight of system on the plumbing;
- use flexible piping to connect main piping to softener;
- be sure all soldered pipes are fully cooled before attaching plastic valve to the plumbing.

5.6 Block diagram and configuration example

Block diagram

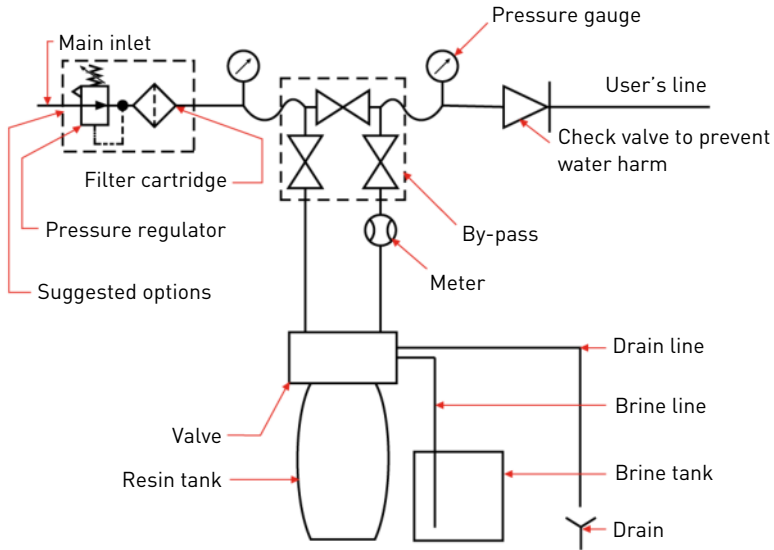

Top mounted configuration example For Europe

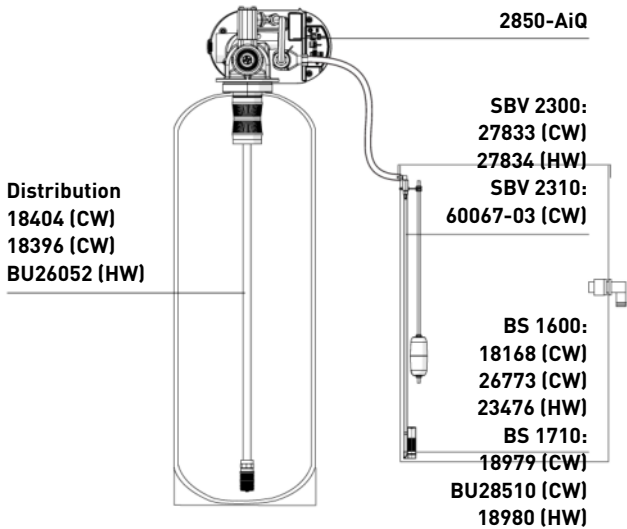

**Side mounted configuration example
For Europe**

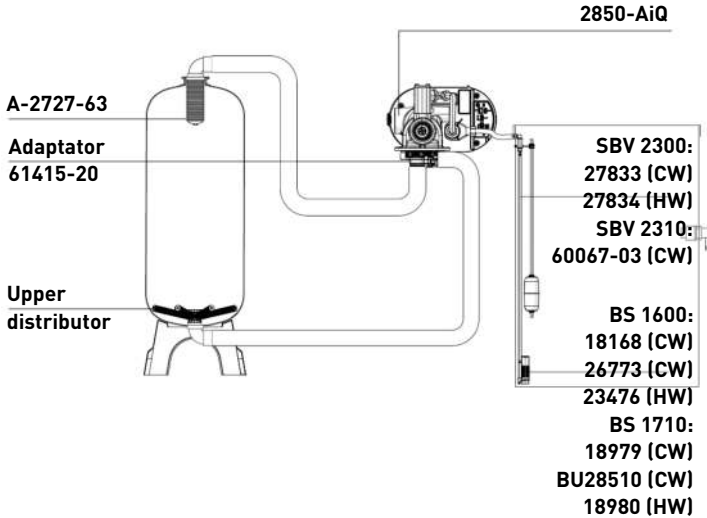

5.7 Valve on tank assembly

1. Lubricate the seals with approved silicone grease.
2. Spin the valve (1) onto the tank (2), ensuring the threads are not cross-threaded.
3. Rotate the valve (1) clockwise and freely, without using force until it comes to a stop.

Info



This stop position is considered point zero.

4. Rotate the valve (1) clockwise from point zero to between ¼ turn and ½ turn.

Caution - material



Risk of damage due to excessive force!

Do NOT exceed 19.9 ft-lb (27 Nm) of torque when installing the valve. Exceeding this limit may damage the threads and cause failure.

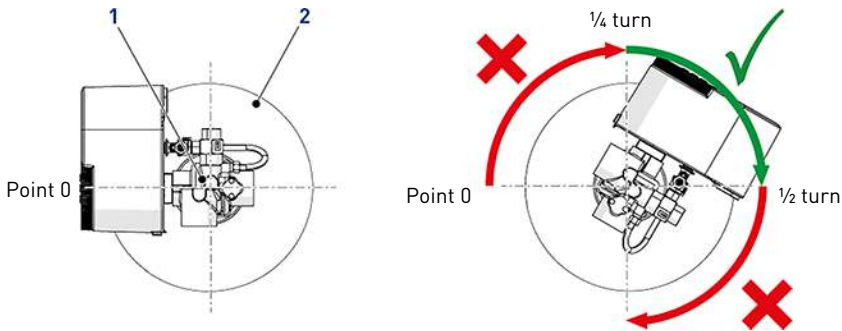

5.8 Valve connection to piping

The connections should be hand tightened using PTFE (plumber’s tape) on the threads if using the threaded connection type.

In case of heat welding (metal type connection), the connections should not be made to the valve when soldering.

Tip



See chapter Components description and location [→Page 19] to identify the connections.

When pressurized, any composite tank will expand both vertically and circumferential. In order to compensate the vertical expansion, the piping connections to the valve must be flexible enough to avoid overstress on the valve and tank.

5.8.1 Top-mounted valve installation

The valve and tank should not be supporting any part of the piping weight. This is hence compulsory to have the piping fixed to a rigid structure (e.g. frame, skid, wall, ...) so that the weight of it is not applying any stress on the valve and tank.

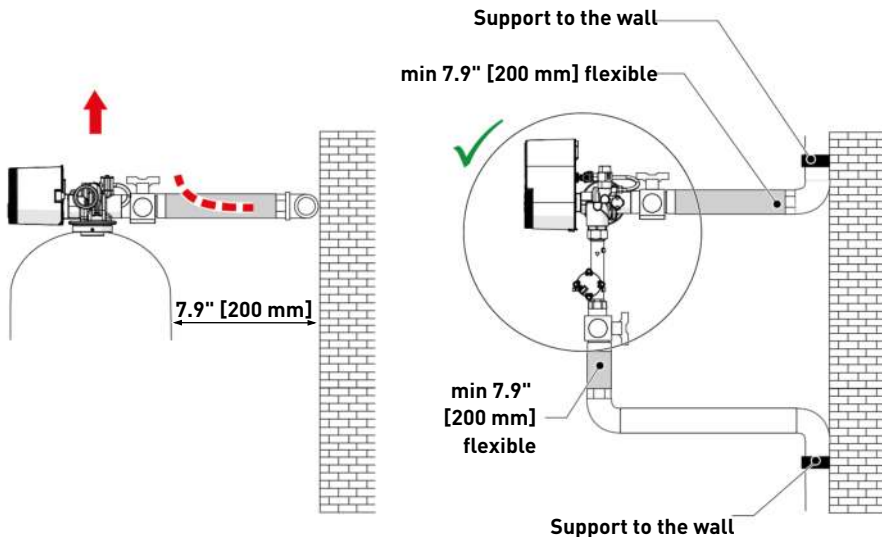

- The diagrams above illustrate how the flexible piping connection should be mounted;
- in order to adequately compensate the tank elongation, the flexible tubes must be installed **horizontally**;
- should the flexible piping connection be installed in vertical position, instead of compensating the elongation, it will create additional stresses on the valve & tank assembly. Therefore, this is to be avoided;
- the flexible piping connection must also be installed stretched, avoiding excessive length. For instance, 7.9" to 15.8" (20 to 40 cm) is enough;
- excessively long and non-stretched flexible piping connection will create stresses on the valve and tank assembly when the system is pressurized, as illustrated in the below picture: on the left the assembly when the system is unpressurized, on the right the flexible piping connection when put under pressure tends to lift up the valve when stretching up. This configuration is even more dramatic when using semi-flexible piping;
- failure to provide enough vertical compensation may lead to different kinds of damage, either on the valve thread which is connected to the tank, or on the female thread connection of the tank. In some cases, damage may also be seen on the valve inlet and outlet connections;

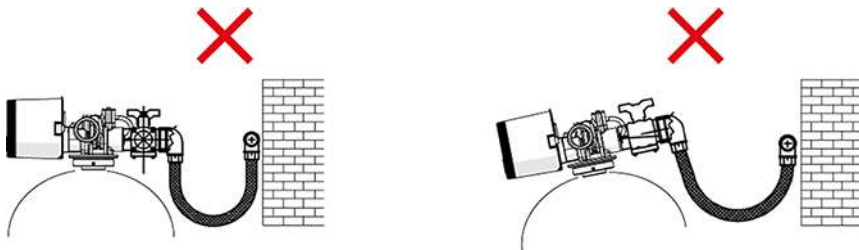

- in any case, any failure caused by improper installations and/or piping connections may void the warranty of Pentair products;

- in the same way, using lubricant* on the valve thread is not allowed and will void the warranty for the valve and tank. Indeed, using lubricant there will cause the valve to be over-torqued, which may lead to valve thread or tank thread damage even if the connection to piping has been done following the above procedure.

*Note: do not use petroleum or hydrocarbon-based lubricants. Using these types of lubricants will structurally damage valve and cause failures. Use only 100 % silicone lubricants.

5.8.2 Side-mounted valve installation

Valid for location having a reduced height.

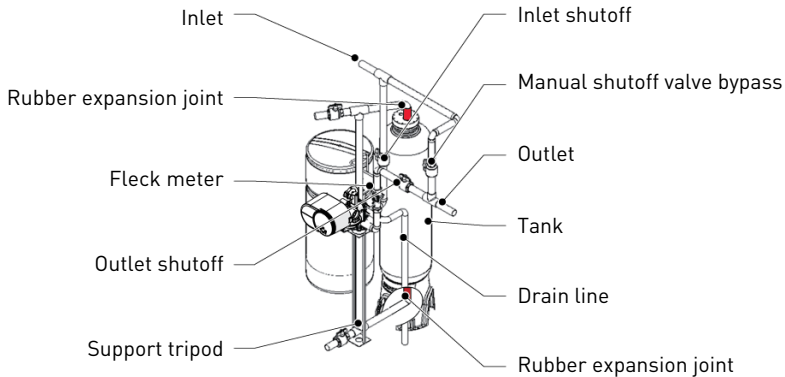

- To avoid the piping supporting the valve and side adapter weight, they must be fixed on a tripod or any other appropriate support;
- in order to adequately compensate the tank elongation, the rubber expansion joints must be mounted on the top and bottom of the tank. In red on the diagram above.

5.9 Regeneration mode

Mandatory



For all multiple tank systems parallel, NBP version valves must be used!

For all multiple tank systems alternating, WBP version valves must be used in combination with solenoid valves in the outlet!

Metered immediate:

The controller monitors the volume of water used. As soon as the capacity is exhausted, the controller starts the regeneration process.

Metered delayed:

The controller monitors the volume of water used. When the remaining capacity is less than the programmed reserve, the controller queues a regeneration that will start at the programmed regeneration time.

Time clock:

The controller initiates the regeneration at regular preset time interval at the programmed regeneration time.

Remote regen start:

The controller initiates the regeneration when an external dry signal is acquired using the flow meter input port, signal must last at least the programmed signal duration.

Day of the week

The controller initiates the regeneration at the programmed regeneration time on preset day(s) of the week.

5.9.1 Single valve (System 4)

As named, this system works with only one valve. The regen can be initiated upon the treated volume (delayed or immediate), time clock mode, an external remote regen signal or day of week.

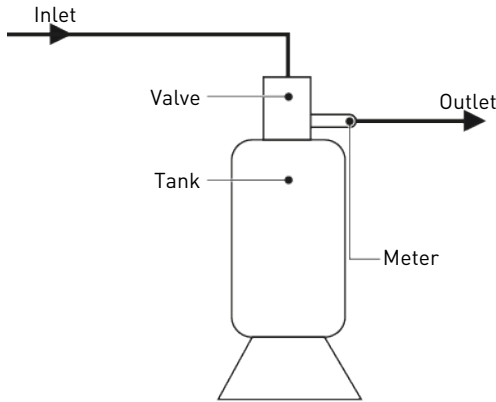

5.10 Electrical connections

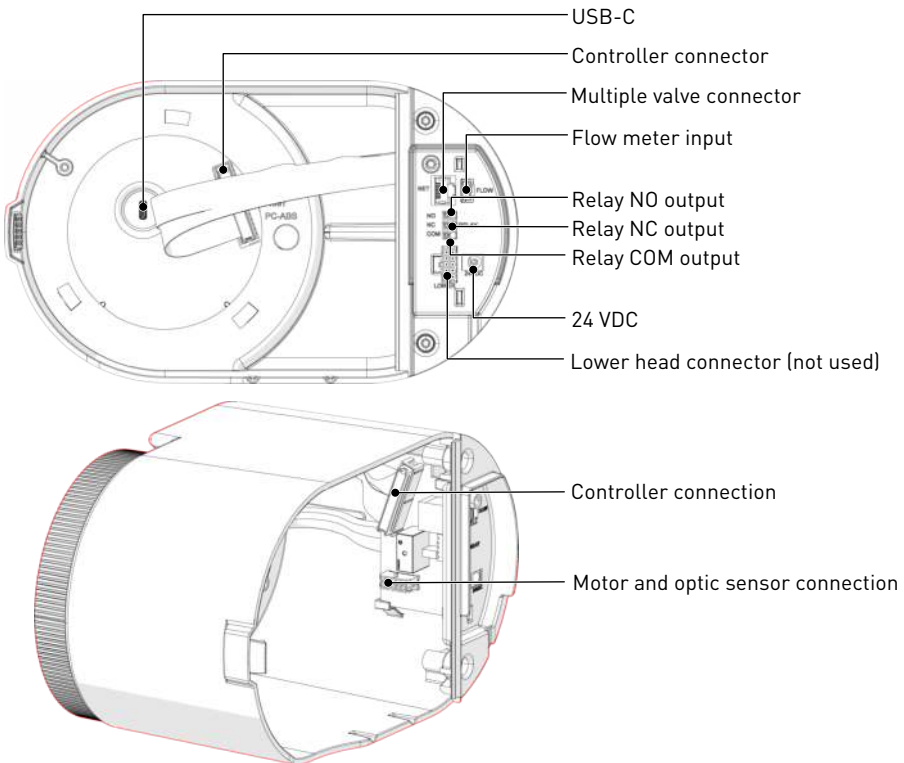

| | Max. rated V | Max. rated A | Type | Usage |
|--------------------------------------|-----------------|-----------------|---------------------------|-----------------------------|
| Controller connection | 24 VDC | 1.04 | PCIe Connector | Power supply, Data transfer |
| USB-C | 5 VDC | 0.5 | USC-C Connector | Power supply, Data transfer |
| 24 VDC | 24 VDC | 1.04 | DC Barrel 5.5 x 2.1 mm | Power supply |
| Multiple valve connector | 24 VDC | 1.04 | Ethernet Connector | Power supply, Data transfer |
| Relay | 24 VDC | - | Terminal Blocks | External input/output |
| Lower head connector | 24 VDC | 1.04 | PCIe Connector | Power supply, Data transfer |
| Flow meter input | 24 VDC | 0.1 | PCIe Connector | Data transfer |
| Motor and optic sensor connection | 24 VDC | 0.8 | PCIe Connector | Power supply, Data transfer |
| Optic sensor connector | 3.3 VDC | 0.1 | PCIe Connector | Data transfer |

5.11 Bypassing

A bypass valve system should be installed on all water conditioning systems. Bypass valves isolate the softener from the water system and allow unconditioned water to be used. Service or routine maintenance procedures may also require that the system is bypassed.



Caution - material



Risk of damage due to bad mounting!

Do not solder pipes with lead-based solder.

Do not use tools to tighten plastic fittings. Over time, stress may break the connections. When the bypass valve is used, only hand tighten the plastic nuts.

Do not use petroleum grease on gaskets when connecting bypass plumbing. Use only 100% silicone grease products when installing any plastic valve. Non-silicone grease may cause plastic components to fail over time.

5.12 Drain line connection

Info



Standard commercial practices are expressed here.

Local codes may require changes to the following suggestions.

Check with local authorities before installing a system.

Mandatory



The drain line must be built with 1" PVC rigid tube! An air gap must be present at the drain!



CAUTION



Risk of injury due to whipping hose!

Flexible and semi-flexible hoses may bend and whip during draining.

The drain line may be elevated up to 70.9" (1.8 m) provided the run does not exceed 181.1" (4.6 m) and water pressure at the softener is not less than 40 psi (2.76 bar) (0.3 Mpa). Elevation can increase by 24" (61 cm) for each additional 10 psi (0.69 bar) (0.1 Mpa) of water pressure at the drain connector.

Where the drain empties into an overhead sewer line, a sink-type trap must be used.

Secure the end of the drain line to prevent it from moving.

Mandatory



Waste connections or the drain outlet shall be designed and constructed to provide connection to the sanitary waste system through an air-gap of 2 pipe diameters or 2" (50.8 mm), whichever is larger.

Caution - material



Risk of damage due to lack of gap!

Never insert the drain line directly into a drain, sewer line or trap. Always allow an air gap between the drain line and the waste water to prevent the possibility of sewage being back-siphoned into the softener.

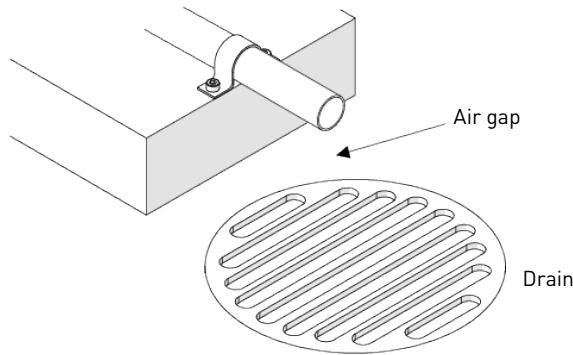

5.13 Overflow line connection

In the event of a malfunction, the brine tank overflow fitting will direct "overflow" to the drain instead of spilling on the floor. This fitting should be on the side of the brine tank. Most brine tank manufacturers feature a pre-drilled hole for the tank overflow connector.

To connect the overflow line, locate the hole on the side of the tank. Insert the overflow fitting into the tank and tighten with plastic thumb nut and gasket as shown below. Attach a 1" I.D. tubing (25.4 mm)(not supplied) to fitting and run to drain.

Do not elevate overflow higher than overflow fitting.

Do not tie into the drain line of the controller unit. The overflow line must be a direct, separate line from overflow fitting to drain, sewer or tub. Allow an air gap as per drain line instructions.

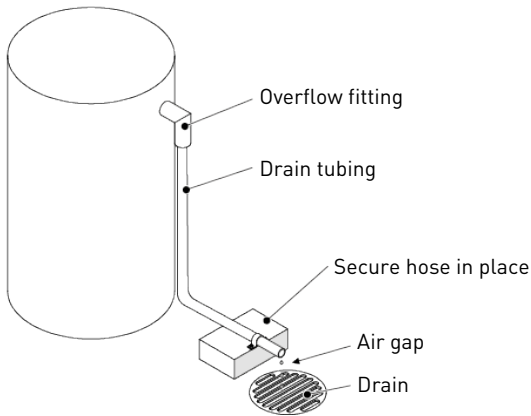

Caution - material



Risk of flooding due to lack of floor drain!

Floor drain is always recommended to avoid flooding in case of overflow.

5.14 Brine line connection

Mandatory



For brine line with 1600/1650 brine valve, use 3/8" semi rigid piping!

For brine line with 1700/1710 brine valve, use 1/2" semi rigid or rigid piping!

Caution - material



Risk of malfunction due to the use of wrong equipment!

Flexible and semi-flexible hoses may shrink because of the vacuum during brine draw.

The brine line connects the valve to the brine tank. Make the connections and hand tighten. Be sure that the brine line is secure and free from air leaks. Even a small leak may cause the brine line to drain out, and the softener will not draw brine from the tank. This may also introduce air into the valve, causing problems with the valve operation.

Brine line must be equipped with brine tank air check in the brine tank.

6 Programming

6.1 Display

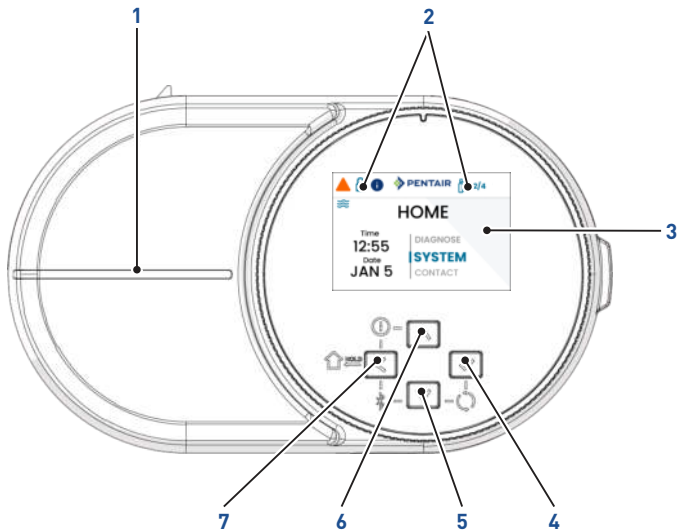

1 Status Indicator Light

- yellow: quick settings
- pulsating yellow: warning
- white: in service
- pulsating white: standby
- green: regeneration in progress
- pulsating green: regeneration queued
- pulsating red: error

2 Icons

- alarm: the system has encountered an error
- locked: access to main **Settings**
- unlocked: access to **Settings** unlocked
- info: information screen available by pressing +

Example:

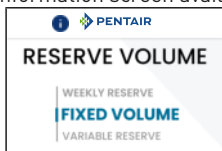

- flow: turbine pulses were detected in the last 5 seconds sample period
- multiplex system: the valve is part of a multiplex system

- **2/4** tank no: in a multi-tank system, this reflects the tank number associated to this control (under development)

- | | |
|-------------------------|--|
| 3 Screen | Displays the menu data |
| 4 Confirm button | Confirms/saves the displayed value |
| 5 Down button | Adjust menu selection/value down |
| 6 Up button | Adjust menu selection/value up |
| 7 Back button | Go to previous menu/mode or undo changes on parameters |

6.2 Program structure and navigation

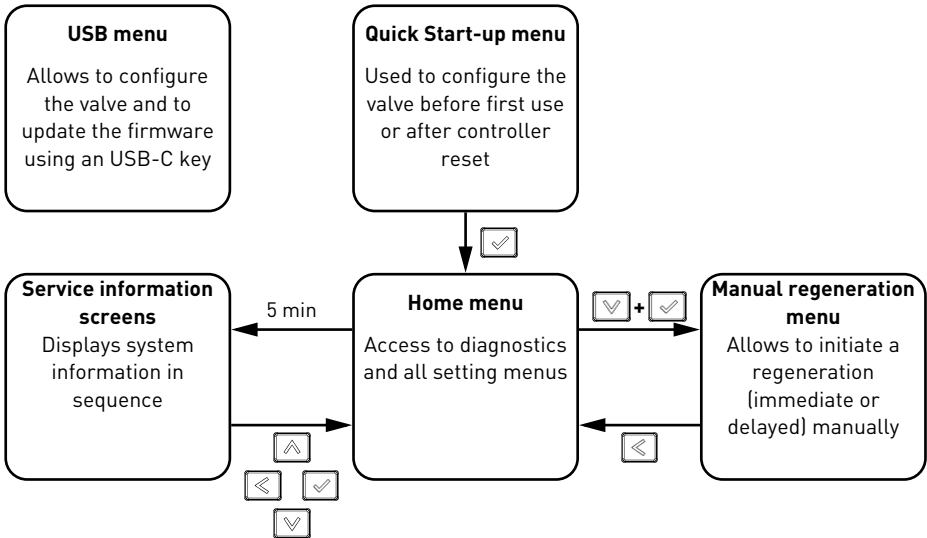

- On **Service information** screens, hold the back button to go to **Home** menu.
- + displays **Information** about the displayed menu (when is displayed).
- + access to **Manual regeneration** menu.
- On **Manual regeneration** menu, goes back to **Home** menu.

Upon first use, the controller displays the **Quick Start-up** menu. Once the initial setup is done, the controller displays the **Home** menu.

6.2.1 Parameter setting

Info



When a parameter is selected, the editable option is displayed in blue.

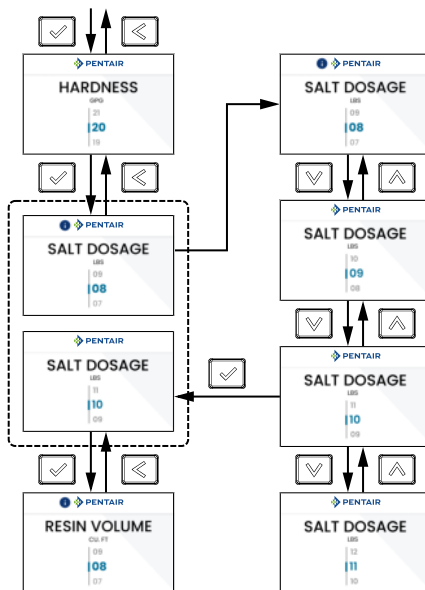



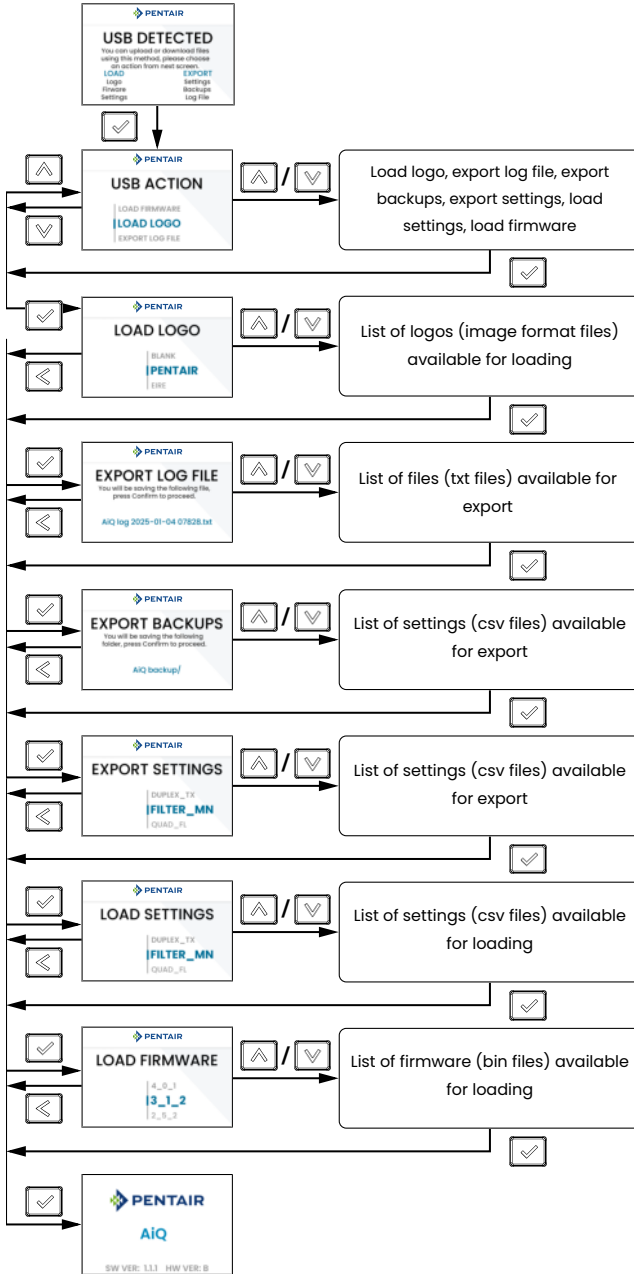

The parameters are set the same way for all menus. Once the submenu selected, set the submenu parameters.

1. Using and , scroll between the different parameters to select the one to set.
 - ⇒ **Salt dosage** actually set at **08 LBS**, in the example above.
2. Press to validate the selection.
3. Using and , scroll between the different values to set the parameter.
 - ⇒ From **08** to **10**, in the example above.
4. Press to validate the setting.
 - ⇒ **Salt dosage** is now set at **10 LBS**, in the example above.
5. Repeat this procedure as needed.
6. Press to exit the submenu settings and to return to the **Home** menu.

6.2.2 USB menu structure



-  enters the **USB** menu and confirms selection.
-  displays **Previous** submenu/parameter.
-  displays **Next** submenu/parameter.
-  goes **Back** to previous menu level.

6.2.3 Quick Start-up menu structure and navigation

Info
Quick Start-up menu is only accessible when first powered on or after controller reset.

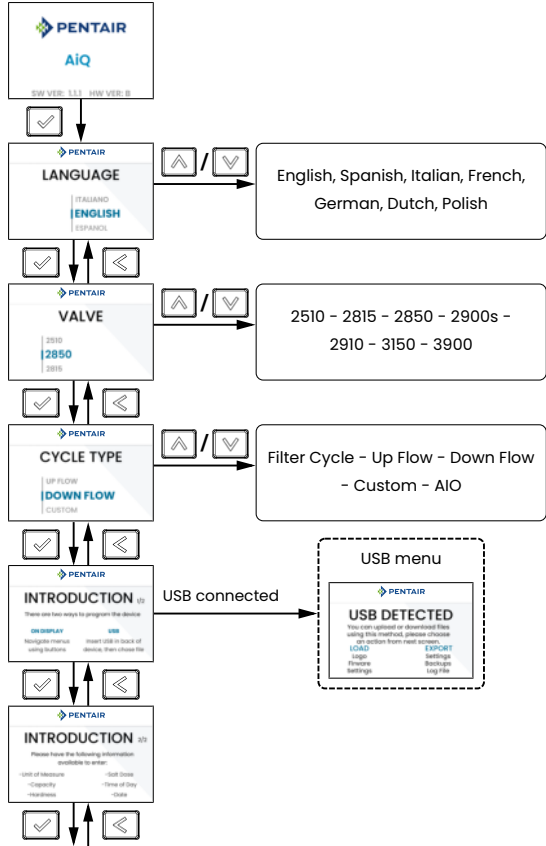

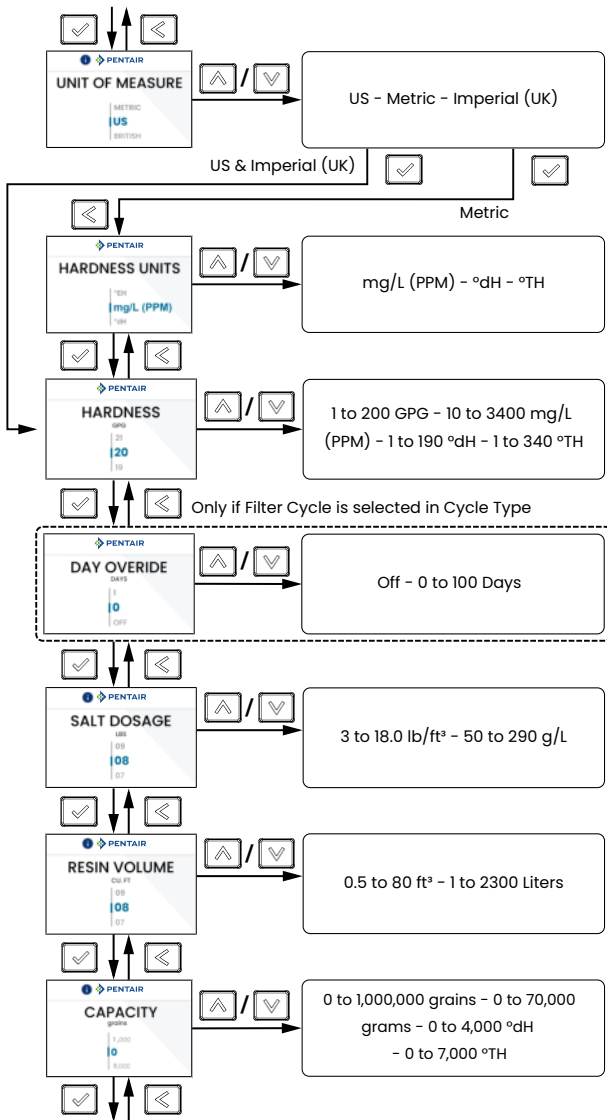

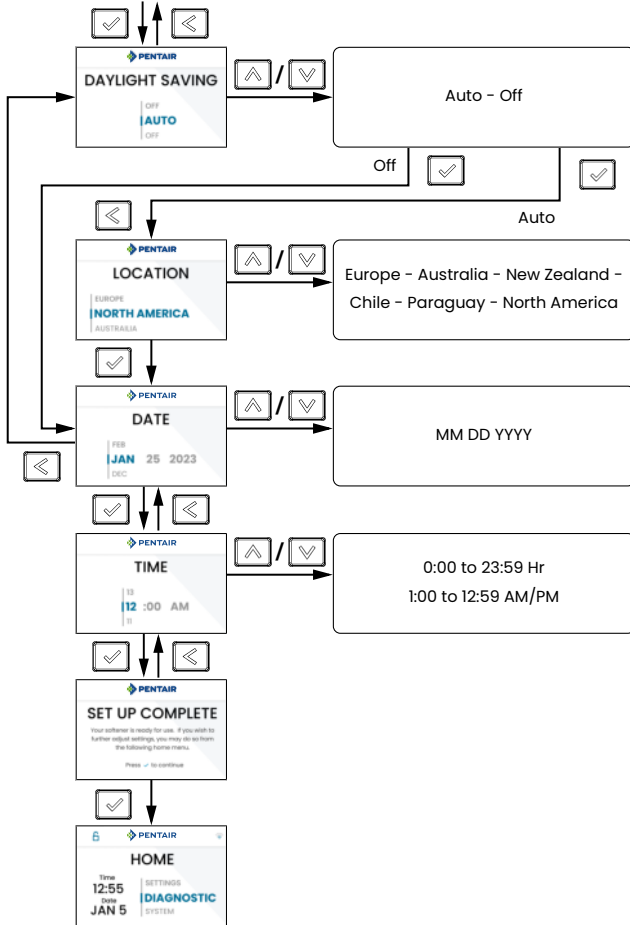

Quick Start-up menu allows to set the main parameters to use the valve. Once the parameters are set, the controller goes to **Service** screens.

6.2.4 Home menu structure and navigation

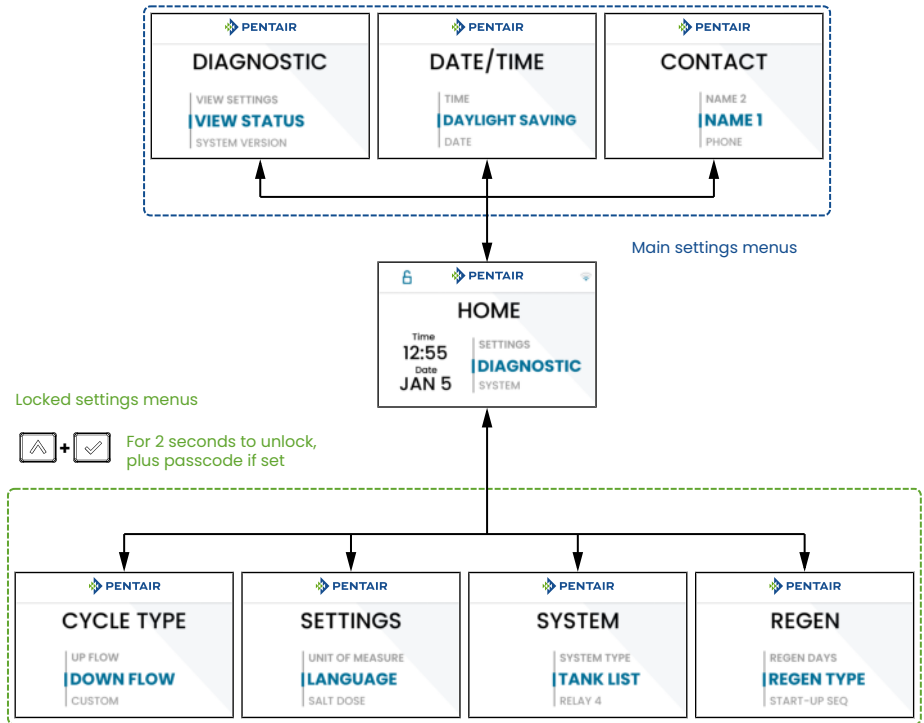

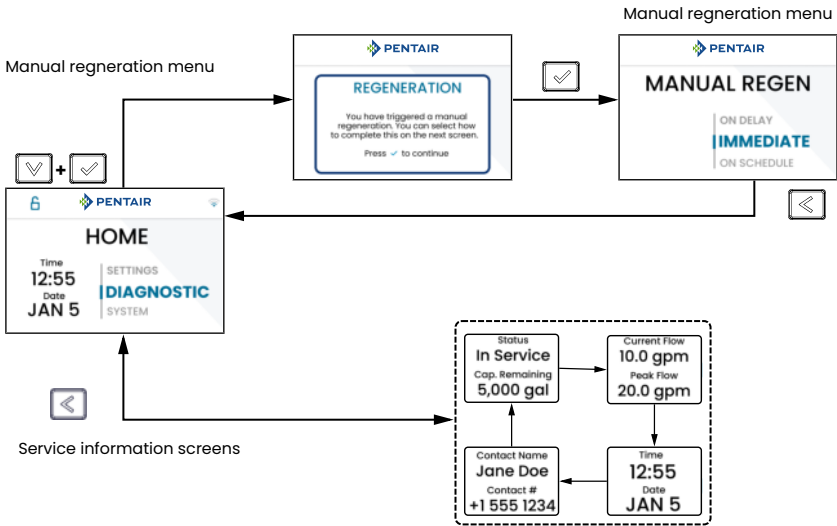

- On **Service information** screens, , , and access to **Home** menu.
- + displays the **Manual regeneration** menu.
- + for 2 seconds (plus passcode if set) unlocks the access to **Cycle, Settings, System** and **Regeneration** menus.
- displays **Previous** menu option.
- displays **Next** menu option.
- returns to previous menu. Pressed for 2 seconds, returns to the **Home** menu.
- valid selection.

In service mode, after 5 minutes, the controller displays successively the different service information screens.

The **Home** menu gives direct access to **Diagnostics, Time/Date, Contact** and **Manual regeneration** menus.

The access to **Cycle, Settings, System** and **Regeneration** menus must be unlocked by pressing + for 2 seconds (plus passcode if set).

Exiting any of these menus returns the controller to the home menu.

6.2.5 Diagnostics menu structure and navigation

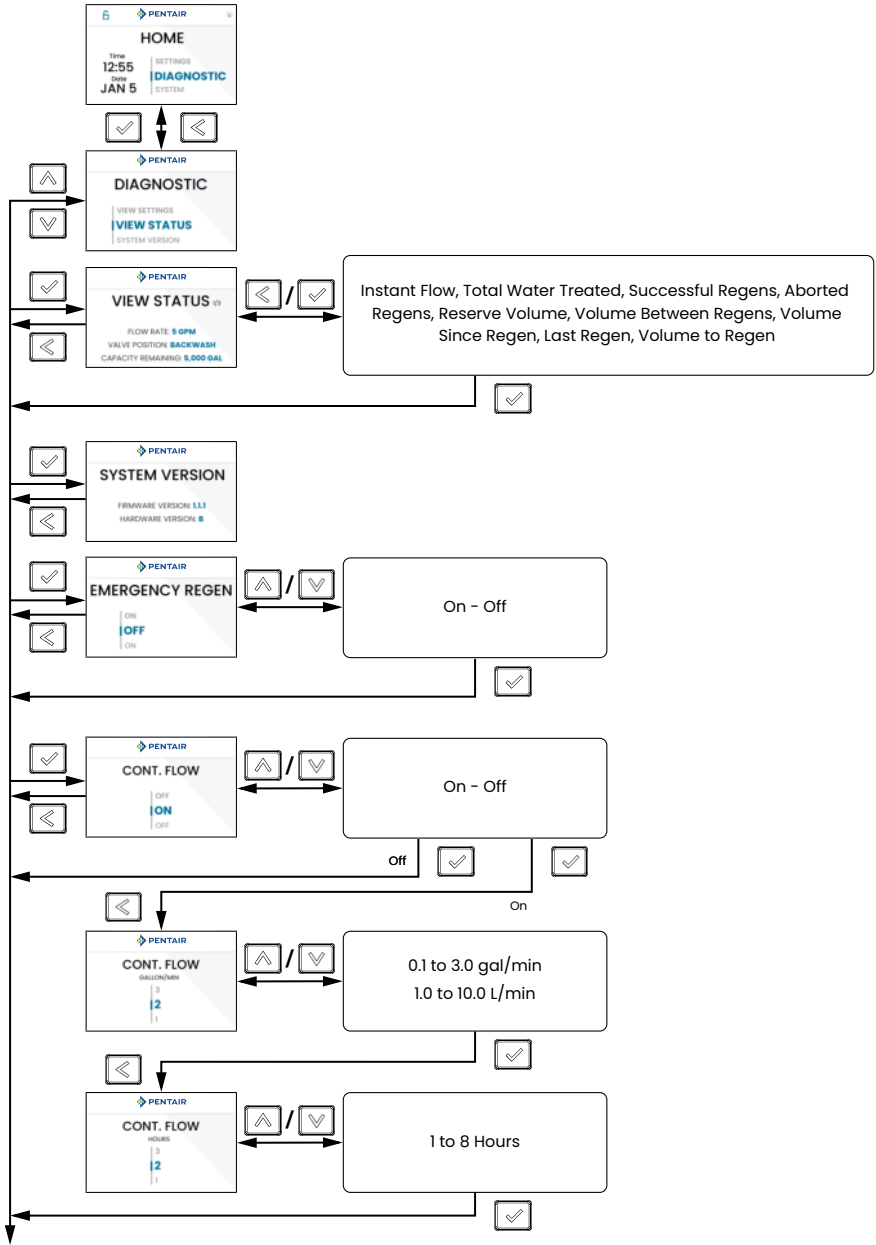

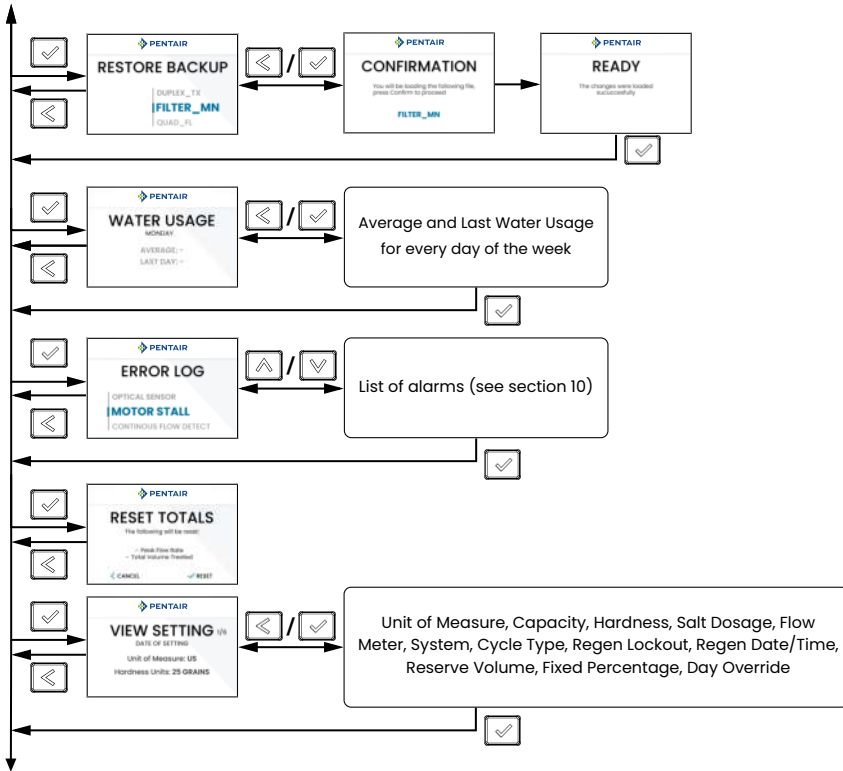

- enters the **Diagnostics** menu from the **Home** menu and confirms access the different **Diagnostics** submenus.
- displays **Previous** submenu/parameter.
- displays **Next** submenu/parameter.
- returns to previous submenu. Pressed for 2 seconds, returns to the **Home** menu.

Diagnostics can be used to display valve operating data, restore backups and set service reminder, continuous flow detection and emergency regeneration.

6.2.6 Date/Time menu structure and navigation

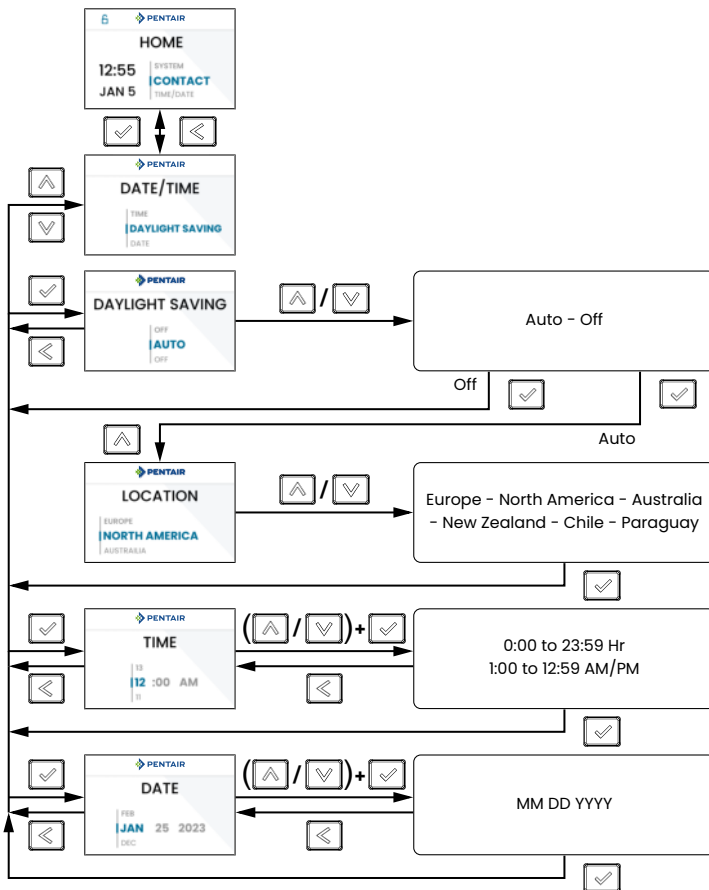

- enters the **Date/Time** menu from the **Home** menu and permits to set the different **Date/Time** submenus.
- displays **Previous** submenu/parameter.
- displays **Next** submenu/parameter.
- returns to previous menu. Pressed for 2 seconds, returns to the **Home** menu.

The **Date/Time** menu lets you set the date, time and location data.

6.2.7 Contact menu structure and navigation

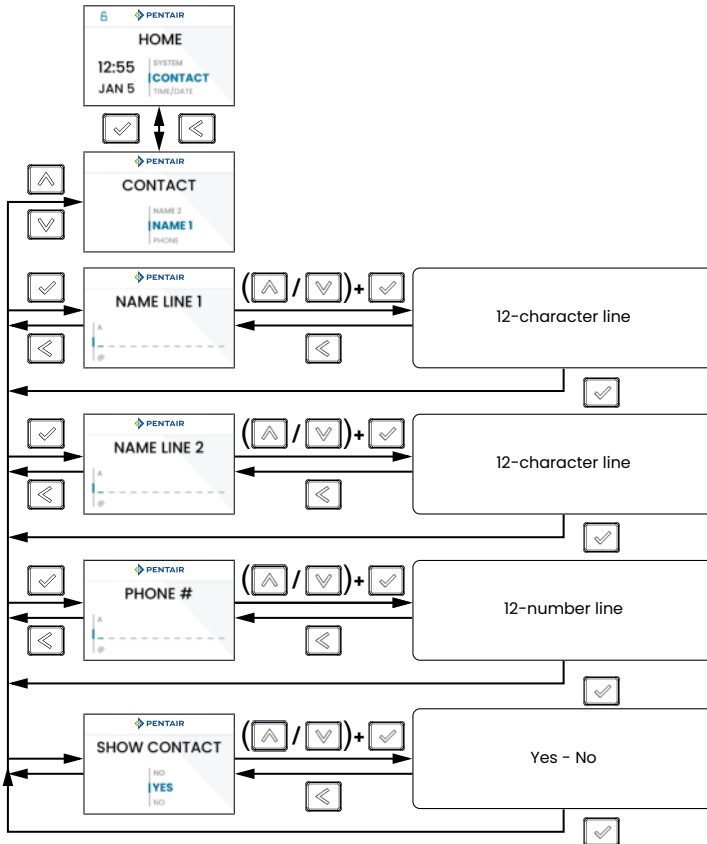

- enters the **Contact** menu from the **Home** menu and permits to set the different **Contact** submenus.
- displays **Previous** submenu/parameter.
- displays **Next** submenu/parameter.
- returns to previous menu. Pressed for 2 seconds, returns to the **Home** menu.

The **Contact** menu lets you define the service contact and telephone number.

6.2.8 Cycle menu structure and navigation

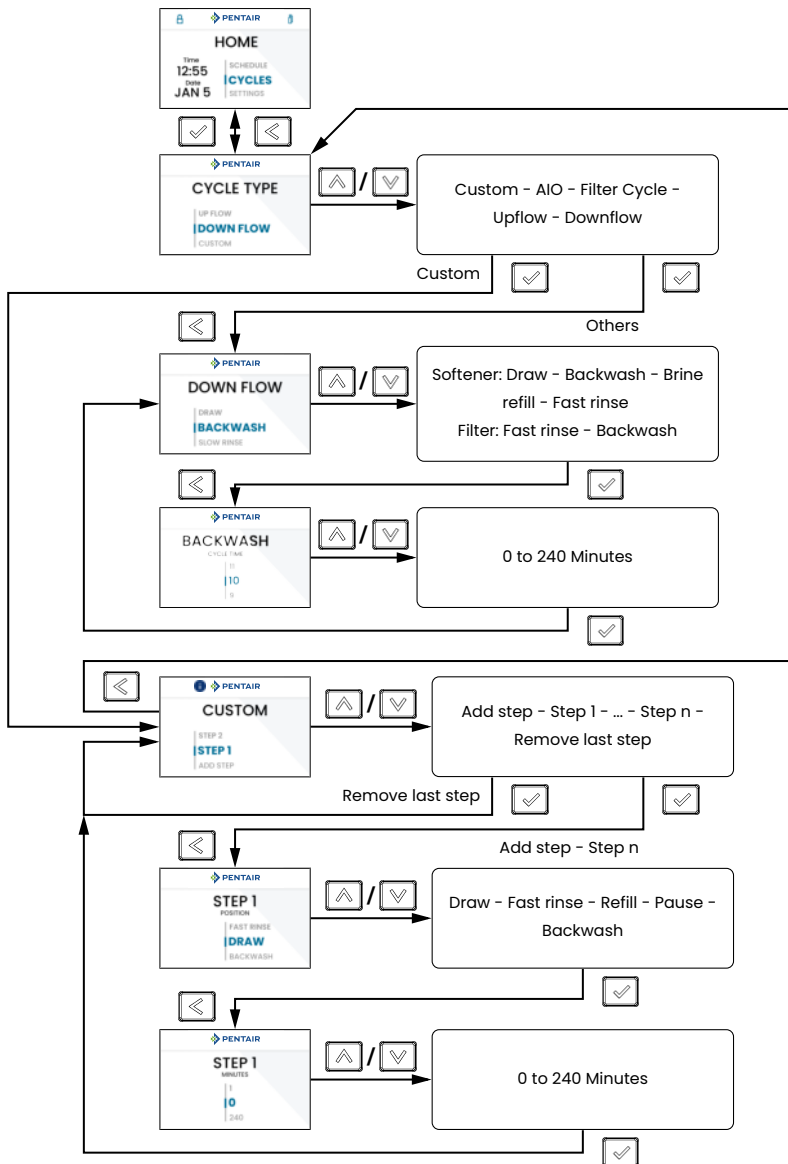

- enters the **Cycle type** menu from the **Home** menu, validate the passcode (if set) and permits to set the different **Cycle type** submenus.
- displays **Previous** submenu/parameter.
- displays **Next** submenu/parameter.

- returns to previous menu. Pressed for 2 seconds, returns to the **Home** menu.

The **Cycle type** menu lets you define the cycle type and time.

6.2.9 Settings menu structure and navigation

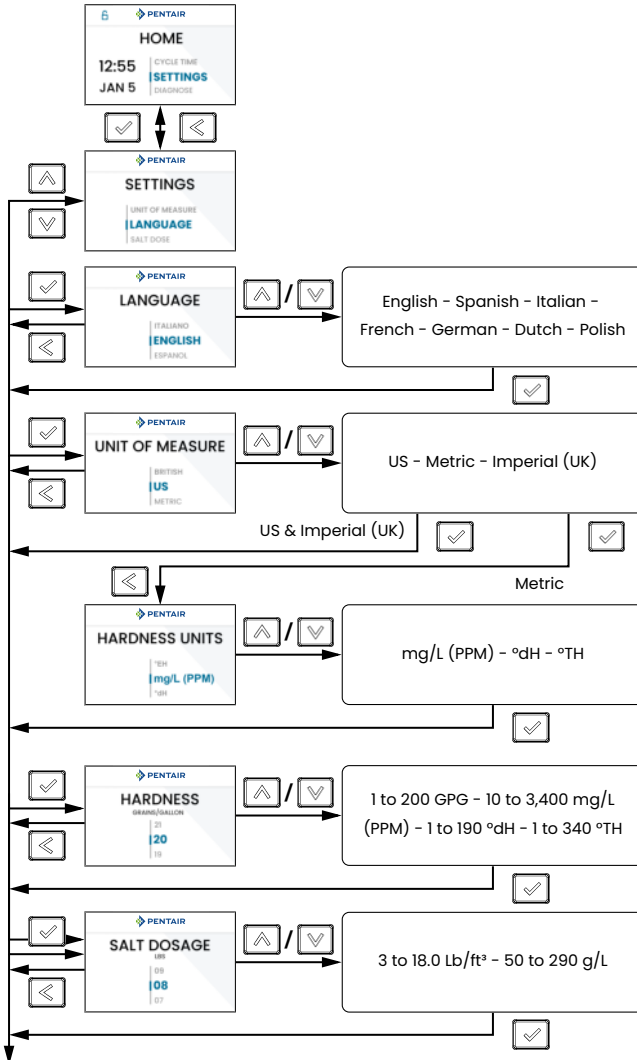

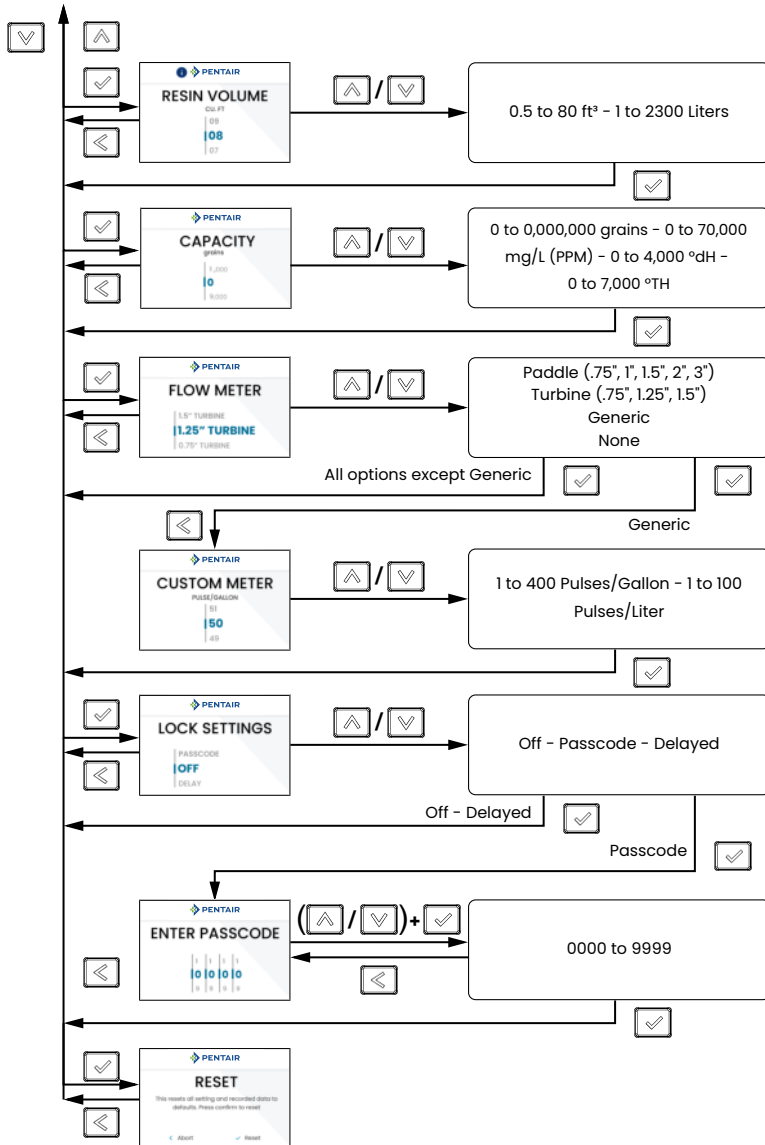

- enters the **Settings** menu from the **Home** menu, validate the passcode (if set) and permits to set the different **Settings** submenus.
- displays **Previous** submenu/parameter.
- displays **Next** submenu/parameter.
- returns to previous menu. Pressed for 2 seconds, returns to the **Home** menu.

The **Settings** menu lets you define the valve parameters.

6.2.10 System menu structure and navigation

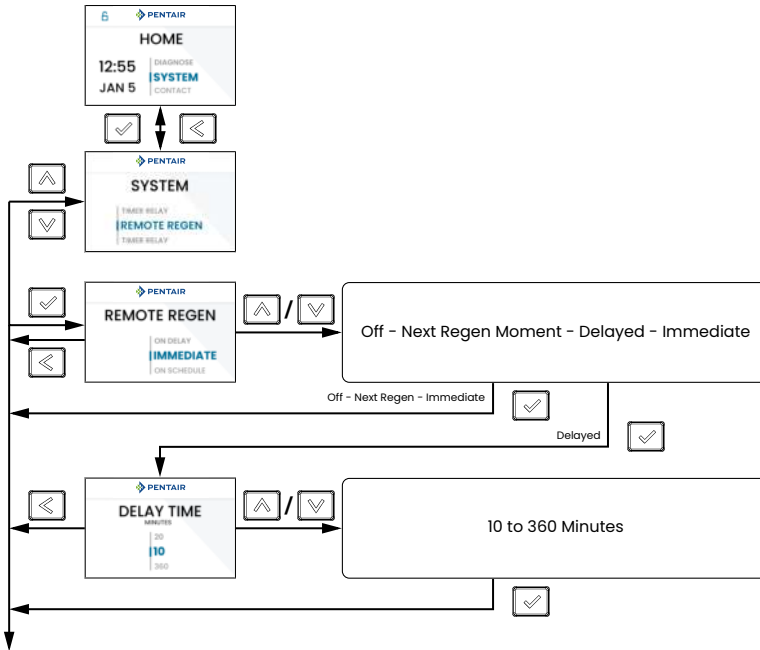

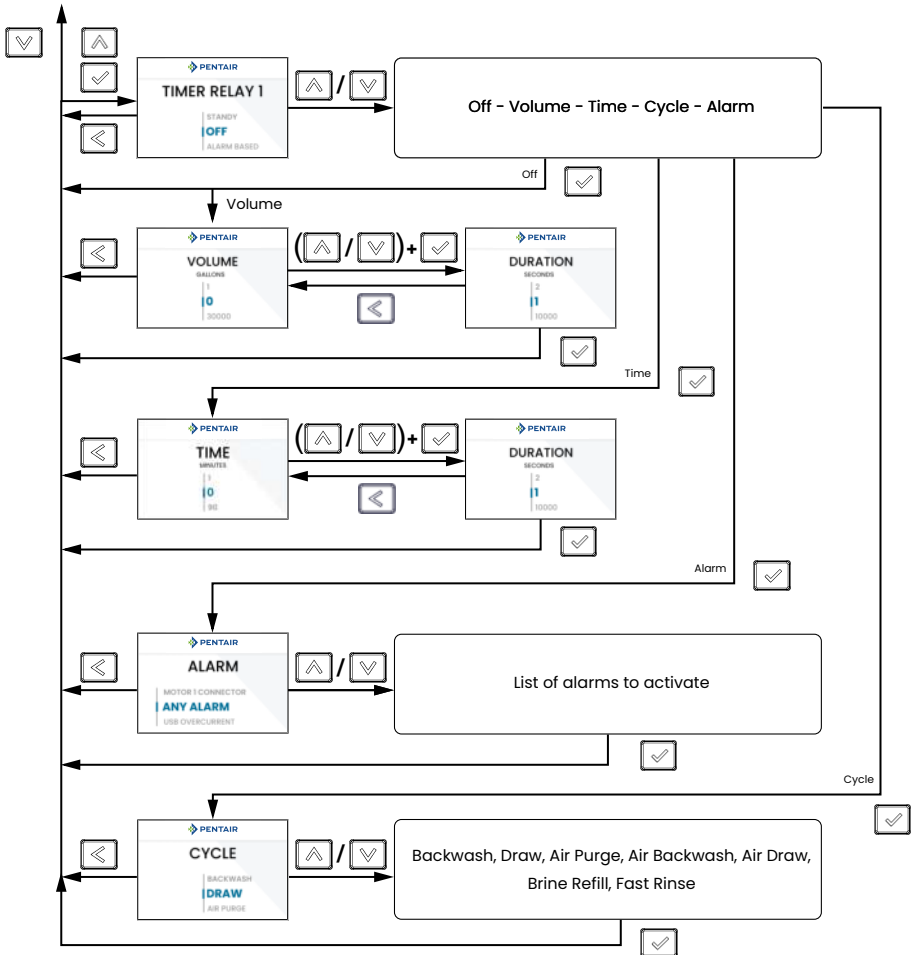

- enters the **System** menu from the **Home** menu, validate the passcode (if set) and permits to set the different **System** submenus.
- displays **Previous** submenu/parameter.
- displays **Next** submenu/parameter.
- returns to previous menu. Pressed for 2 seconds, returns to the **Home** menu.

The **System** menu lets you define the system parameters.

6.2.11 Regeneration menu structure and navigation

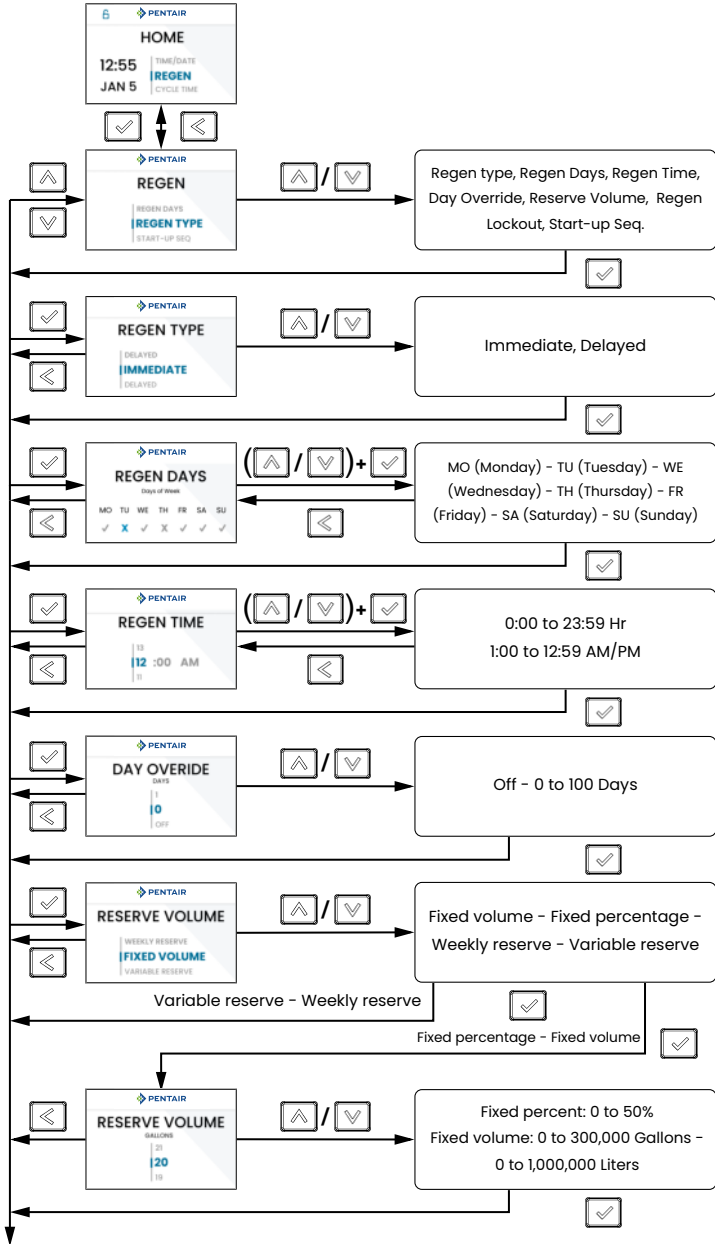

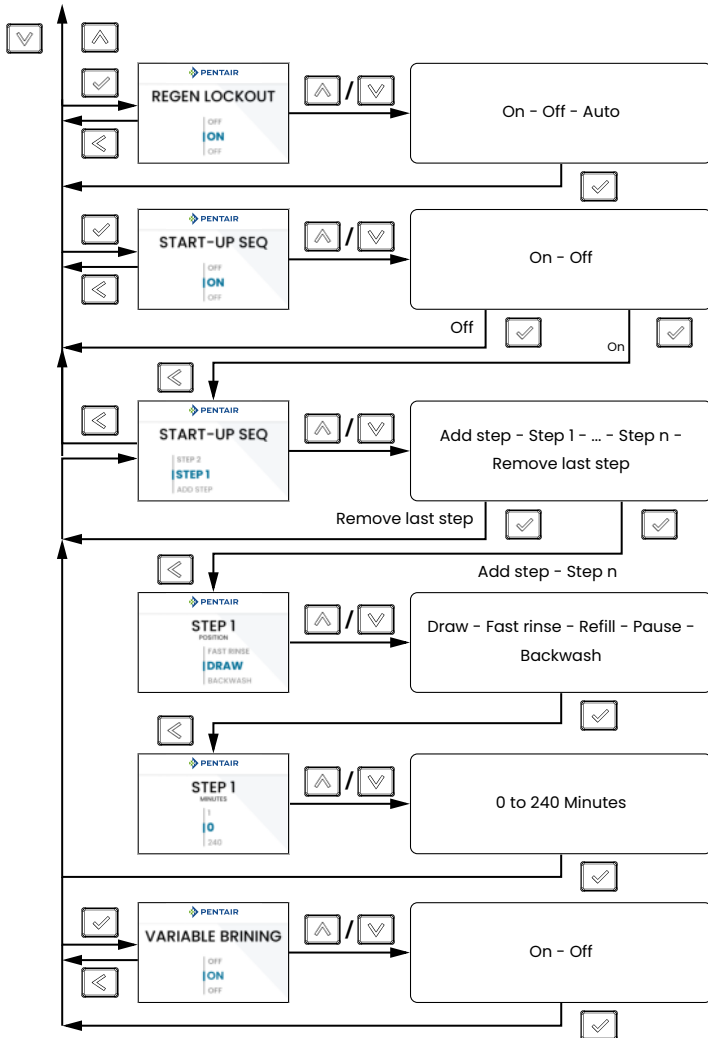

- enters the **Regeneration** menu from the **Home** menu, validate the passcode (if set) and permits to set the different **Regeneration** submenus.
- displays **Previous** submenu/parameter.
- displays **Next** submenu/parameter.
- returns to previous menu. Pressed for 2 seconds, returns to the **Home** menu.

The **Regeneration** menu lets you define the regeneration parameters.

6.3 USB configuration and update

Info



The AiQ controller can be configured and/or updated with a *.csv and/or a *.bin file on an USB-C support.

Options:

- Load settings;
- Load firmware;
- Load logo;
- Export settings;
- Export history.

1. Turn the controller (1) counter-clockwise.
2. Remove the controller (1) from the cover assembly (4).
3. Plug the USB-C key (2) in the USB connector (3).

⇒ The USB detected screen is displayed.

4. Press to enter the **USB action** menu.
5. Using and , scroll to select the desired action.
6. Press to validate the selection.
7. Using and , scroll to select the file to load/export.
8. Press to validate the selection.

⇒ **To load:** The file is loaded into the controller and the setting or firmware is replaced by the file content.

⇒ **To export:** The file is exported into the USB key (2).

USB detected screen

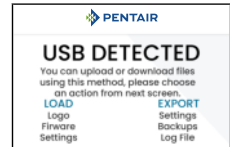

Load settings submenu

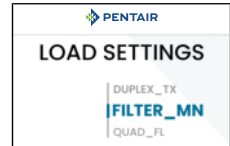

Load firmware submenu



Load logo submenu

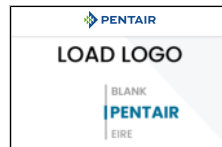

Export settings submenu

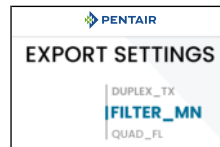

Export history submenu



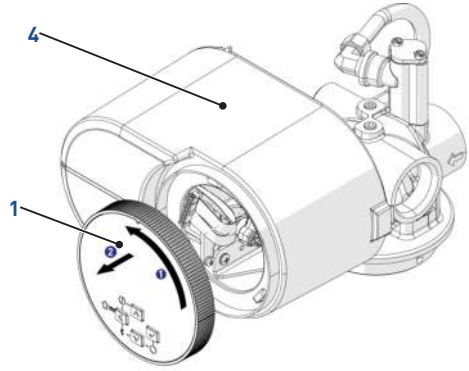
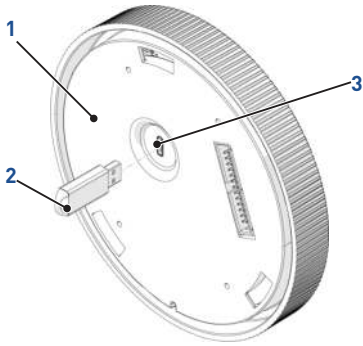

6.4 Quick Start-up setup

At start-up or after controller reset, the controller displays the **Quick Start-up validation** menu. Once validated, the controller goes in **Home** mode displaying **Home** screens.

6.4.1 Quick Start-up mode programming chart

| Parameter description | Range of values | Default value | Units of measure | Notes |
|-----------------------|--|---------------|------------------|---|
| Language | English Spanish Italian French German Dutch Polish | English | - | - |
| Valve | 2510 2815 2850 2900s 2910 3150 3900 | 2850 | - | - |
| Cycle type | Filter Custom Downflow Upflow AIO | Downflow | - | - |
| Unit Of Measure | US Metric Imperial (UK) | US | - | - |
| Hardness Unit | GPG | GPG | - | US or Imperial (UK) unit. Parameter not displayed. |
| | mg/L (PPM) °dH °TH | mg/L (PPM) | - | Metric unit. |

| Parameter description | Range of values | Default value | Units of measure | Notes |
|-----------------------|-----------------|---------------|--------------------|--|
| Capacity | 0 – 1,000,000 | 300,000 | Grain | US unit setting. To be set in the programming tables. Increments of 1`000 unit. |
| | 0 – 70,000 | 19,400 | Gram | Metric unit setting. Increments of 100 units. |
| | 0 – 4,000 | 1,090 | °dHm ³ | Metric unit setting. Increments of 10 units. |
| | 0 – 7,000 | 1,940 | °THm ³ | Metric unit setting. Increments of 10 units. |
| Hardness | 0 – 200 | 20 | GPG | US unit setting. To be set in the programming tables. Increments of 1 unit. |
| | 0 – 3,400 | 200 | mg/L (PPM) | Metric unit setting. Increments of 10 units. |
| | 0 – 190 | 12 | °dH | Metric unit setting. |
| | 0 – 340 | 20 | °TH | Increments of 1 unit. |
| Salt Dosage | 3 - 18 | 9.0 | lb/ft ³ | US or UK unit setting. In Installer Setting menu, it is possible to adjust Salt dosage with increments of 0.1 lb/ft ³ of resin for more precise setting. |
| | 50 - 290 | 120 | g/L | Metric unit setting. In Installer Setting menu, it is possible to adjust Salt dosage with increments of 10 g/l of resin for more precise setting. |
| Resin Volume | 0.5 – 80 | 2 | ft ³ | US or UK unit setting. Increments of 0.5 units. |
| | 1 – 2300 | 60 | L | Metric unit setting. Increments of 1 unit. |
| Daylight Savings | Auto Off | Auto | - | The time of day adapts automatically to summertime and standard time. The time zone must be selected according to installation location. |

| Parameter description | Range of values | Default value | Units of measure | Notes |
|-----------------------|--|---------------|------------------|---|
| Location | Europe North America Paraguay Chile New Zealand Australia | North America | - | Displayed only if Daylight Saving is set to Auto. |
| Date | dd/mm/yyyy | 01/01/2025 | - | - |
| Time | 1:00 - 12:59 AM/ PM | 12:00 AM | hour: minute | US unit setting. |
| | 0:00 - 23:59 | 00:00 | | Metric unit setting. |

6.4.2 Language

Select the displayed language.

Options:

- English (Default);
- Spanish;
- Italian;
- French;
- German;
- Dutch;
- Polish.

- Using and , scroll to select the desired language.
- Press to validate the selection.
⇒ The controller displays **Valve** submenu.
- Press to display the previous submenu.
- Press to display the next submenu.

Language submenu









6.4.3 Valve

Select the valve.

Options:

- 2850 (default);
- 2510;
- 2815;

- 2900s;
 - 2910;
 - 3150;
 - 3900.
1. Press  to select the parameter.
 2. Using  and , scroll to select the present valve.
 3. Press  to validate the selection.
 - ⇒ The controller displays the **Cycle type** submenu.
 4. Press  to display the next submenu.
 5. Press  to display the previous submenu.







Valve submenu



6.4.4 Cycle type

Select the cycle type.

Options:

- Filter cycle (default);
 - Custom;
 - Down flow;
 - Up flow.
1. Press  to select the parameter.
 2. Using  and , scroll to select the desired cycle type.
 3. Press  to validate the selection.
 - ⇒ The controller displays the **Introduction** screen.
 4. Press  to display the **Unit of measure** submenu or plug an USB key to load data.
 - ⇒ Refer to USB configuration and update [⇒Page 78].
 5. Press  to display the previous submenu.
 6. Press  to display the next submenu.

Cycle type submenu

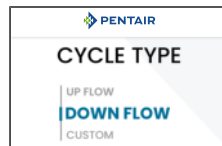

Introduction screen



6.4.5 Unit of measure

Select the unit of measure and, if metric, the hardness unit.

Unit of measure options:

- US (default);
- Metric;
- Imperial (UK).









Metric hardness unit options:

Info



The hardness unit parameter is only displayed when selecting Metric.

If previous selection is US or imperial, hardness unit is automatically grains per gallon (GPG).

- mg/L (PPM) (default);
 - °dH;
 - °TH;
1. Press  to select the parameter.
 2. Using  and , scroll to select the desired unit of measure.
 3. Press  to validate the selection.
 - ⇒ If **US** or **Imperial** is selected, the controller displays the **Capacity** submenu.
 - ⇒ If **Metric** is selected, the controller displays the **Hardness unit** submenu.
 4. Use  and  to select the desired hardness unit.
 5. Press  to validate the selection.
 - ⇒ The controller displays the **Capacity** submenu.
 6. Press  to display the previous submenu.
 7. Press  to display the next submenu.

Unit of measure submenu

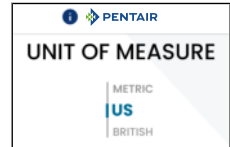

Hardness unit submenu

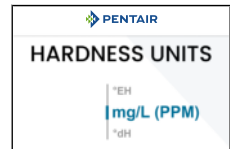

6.4.6 Capacity







Set the system capacity.

US options:

- 1 to 1,000,000 Grains (300,000 default).

Metric options:

- 0 to 70,000 g (19,400 default);
- 0 to 4,000 °dHm³ (1,090 default);
- 0 to 7,000 °THm³ (1,940 default);

1. Press  to select the parameter.
2. Using  and , scroll to set the system capacity as desired.
3. Press  to validate the setting.
⇒ The controller displays the **Hardness** submenu.
4. Press  to display the previous submenu.
5. Press  to display the next submenu.

Capacity submenu

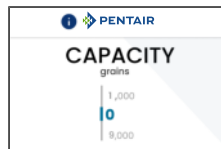

6.4.7 Hardness

Set the inlet water hardness. In case residual hardness at the outlet is set using the internal mixing screw, deduct the measured residual hardness from inlet hardness for programming.

US options:







- 1 to 200 GPG (20 default).

Metric options:

- 10 to 3,400 mg/L (PPM) (340 default);
- 1 to 190 °dH (19 default);
- 1 to 340 °TH (34 default);

UK options:

- 1 to 200 GPG (20 default).

1. Press  to select the parameter.
2. Using  and , scroll to set the inlet water hardness.
3. Press  to validate the setting.
⇒ The controller displays the **Salt dosage** submenu.
4. Press  to display the previous submenu.
5. Press  to display the next submenu.

Hardness submenu

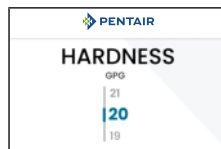

6.4.8 Salt dosage

Set the salt dosage.

US and UK options:

- 3 to 18 lb/ft³ (9.0 default).

Metric options:

- 50 to 290 g/L (140 default).

1. Press to select the parameter.
2. Using and , scroll to set the desired salt dosage.
3. Press to validate the setting.
 - ⇒ The controller displays the **Resin volume** submenu.
4. Press to display the previous submenu.
5. Press to display the next submenu.

Salt dosage submenu



6.4.9 Resin volume

Set the system resin amount.

US and UK options:

- 0.5 to 80 ft³ (1 default);

Metric options:

- 1 to 2300 L (28 default).

1. Press to select the parameter.
2. Using and , scroll to set the resin amount present in the system.
3. Press to validate the setting.
 - ⇒ The controller displays the **Daylight savings** submenu.
4. Press to display the previous submenu.
5. Press to display the next submenu.

Resin volume submenu



6.4.10 Daylight savings









Set the daylight savings.

Options:

- Auto (default);
- Off.

Location options:

- Europe;
- North America (default);
- Paraguay;
- Chile;
- New Zealand;
- Australia.

1. Press  to select the parameter.
2. Using  and , scroll to select the **Auto** option.
3. Press  to validate the selection.
 - ⇒ If **Off** is selected, the controller displays the **Date** submenu.
 - ⇒ If **On** is selected, the controller displays the **Location** submenu.
4. Using  and , scroll to select the location for installation.
5. Press  to validate the selection.
 - ⇒ The controller displays the **Date** submenu.
6. Press  to display the previous submenu.
7. Press  to display the next submenu.

Daylight saving

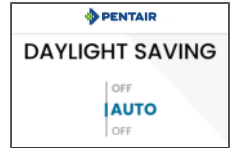

Location



6.4.11 Date







Set the date mm/dd/yyyy.

Options:

- mm

| | | | |
|------|------|------|------|
| Jan; | Apr; | Jul; | Oct; |
| Feb; | May; | Aug; | Nov; |
| Mar; | Jun; | Sep; | Dec. |

- dd
01 to 31.
- yyyy
2025 to 9999.

1. Press  to select the parameter.
2. Using  and , scroll to set the month.
3. Press  to validate month setting.
4. Repeat the previous two steps once to set the day and a second time to set the year.
 - ⇒ Once the **Date** is set, the controller displays the **Time** submenu.
5. Press  to display the previous submenu.
6. Press  to display the next submenu.

Date submenu

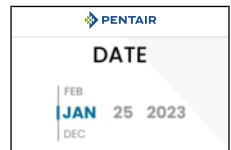

6.4.12 Time

Set the time of day.

US and UK options:

- 01:00 AM to 12:25 PM (12:00 AM default).

Metric options:

- 00:00 to 24:00 (00:00 default).

1. Press to select the parameter.
2. Using and , scroll to set the time hour.
3. Press to validate the hour setting.
4. Repeat the previous two steps to set the minutes.
 - ⇒ Once the **Time** is set, the controller displays the **Set up complete** screen.
5. Press to display the previous submenu.
6. Press to display the next submenu.

Time submenu

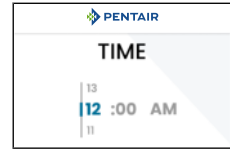

6.4.13 Quick Start-up completed

Info



Once the quick start-up parameters are set, this menu can be displayed again only following to a controller reset.

Save the **Quick Start-up** menu programming and display normal **Home** menu.

1. If necessary, press to display the previous parameter.
2. Press to save **Quick Start-up**.
 - ⇒ The controller displays the **Home** menu.

Set up complete screen





6.5 Home menu

6.5.1 Setting menu selection

Info



The Home menu displays only the available menus.

To display the locked menus, press  +  for 2 seconds.

Select the desired setting menu.



Available menus:

- Diagnostic;
- Date/Time;
- Contact.

Locked menus:

- Cycle;
- Settings;
- System;
- Regeneration.

1. If necessary, press  to come back to the **Home** screens.

2. Using  and , scroll to select the menu to set.

3. Press  to validate the selection.

4. Set the desired parameters.

⇒ Refer to Parameter setting [->Page 59].

5. Press  to come back to the **Home** menu.

Diagnostic



Date/Time

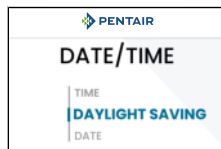

Contact

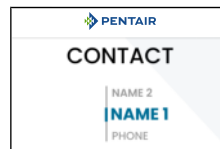

Cycle

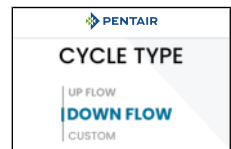

Settings

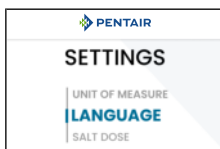

System

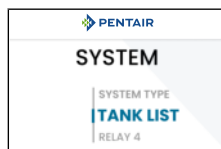

Regeneration



6.5.2 Diagnostic menu

6.5.2.1 Diagnostic setting mode programming chart

| Parameter description | Range of values | Default value | Units of measure | Notes |
|------------------------|-----------------|---------------|------------------|---|
| Continuous flow alert | Off On | Off | - | - |
| Detection flow rate | 0.1 – 3.0 | 0.5 | Gal/min | Displayed only if Continuous flow alert is set to ON. US or Imperial (UK) unit. Increments of 0.1 unit. |
| | 1.0 – 10.0 | 1.9 | L/min | Displayed only if Continuous flow alert is set to ON. Metric unit. Increments of 0.1 unit. |
| Detection time | 1 – 8 | 1 | Hour | Displayed only if Continuous flow alert is set to ON. |
| Emergency regeneration | On Off | On | - | - |







6.5.2.2 Settings

Check the system status.

Information displayed:

- Unit of measure;
- Hardness units;
- Capacity;
- Hardness (inlet);
- Salt dosage;
- Flow Meter.

6.5.2.3 Diagnose

1. Access the **Diagnostic** menu.
2. Using  and , scroll to select the **View setting** submenu.
3. Press  to validate the selection.
4. If necessary, use  and  to consult the different setting screens.
5. Press  to return to **Diagnostics** menu.

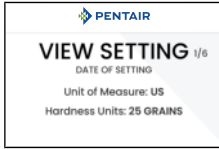
First view setting screen

Second view setting screen

Capacity
Hardness
Salt Dosage

Third view setting screen

Flow Meter
System

Fourth view setting screen

Cycle Softener
Regen Type

Fifth view setting screen







Regen Date
Time on Control

Sixth view setting screen

Reserve Volume
Fixed Volume
Day Override

6.5.2.4 Error log

Check the error log.

- Error type and occurrence date.
1. Access the **Diagnostic** menu.
 2. Using  and , scroll to select the **Error log** submenu.
 3. Press  to validate the selection.
 4. If necessary, using  and , scroll to consult the different errors.
 5. Press  to access the selected error information.
 6. Press  to return to **Diagnostics** menu.

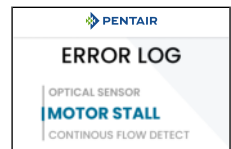





Error log submenu

6.5.2.5 Status

Check the system status.

Information displayed:

- Flow rate;
- Peak flow rate;
- Tank in service;
- Available treated water;
- Valve position;
- Last regeneration date;
- Average regeneration interval.



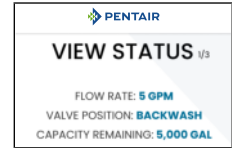

1. Access the **Diagnostic** menu.
2. Using  and , scroll to select the **View Status** submenu.
3. Press  to validate the selection.
4. If necessary, use  and  to consult the different status screens.
5. Press  to return to **Diagnostics** menu.

First status screen



6.5.2.6 Reset totals

Resets the system status.

1. Access the **Diagnostic** menu.
2. Using  and , scroll to select the **Reset totals** submenu.
3. Press  to validate the selection.
4. Press  to confirm reset.
 - ⇒ After reset, the controller returns to **Diagnostic** menu.

Reset totals submenu









6.5.2.7 Water usage

Check the water usage history.

Information displayed:

- Average flow Mondays (last 4 Mondays);
- Flow last Monday (current past Monday);
- Average flow Tuesdays (last 4 Tuesdays);
- Flow last Tuesday (current past Tuesday);
- Average flow Wednesdays (last 4 Wednesdays);
- Flow last Wednesday (current past Wednesday);
- Average flow Thursdays (last 4 Thursdays);
- Flow last Thursday (current past Thursday);
- Average flow Fridays (last 4 Fridays);
- Flow last Friday (current past Friday);
- Average flow Saturdays (last 4 Saturdays);
- Flow last Saturday (current past Saturday);
- Average flow Sundays (last 4 Sundays);
- Flow last Sunday (current past Sunday).

1. Access the **Diagnostic** menu.
2. Using  and , scroll to select the **Water Usage** submenu.
3. Press  to validate the selection.
4. If necessary, use  and  to consult the different history screens.
5. Press  to return to **Diagnostics** menu.

Monday use

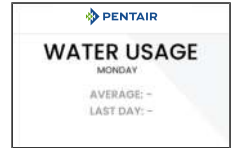







6.5.2.8 Service reminder

Set the service reminder.

Options:

- Off (default);
- 1 to 48 months.

1. Access the **Diagnostic** menu.
2. Using  and , scroll to select the **Service reminder** submenu.
3. Press  to validate the selection.
4. Use  and  to set the **Service reminder**.
5. Press  to validate the setting.

Service reminder submenu

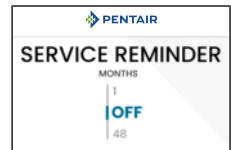

⇒ The controller returns to **Diagnostics** menu.

6.5.2.9 Continuous flow

Set the continuous flow alert.

Options:

- Off (default);
- ON.

US options:

- 0.1 to 3.0 Gal/min (0.5 default);
- 1 to 8 hours (1 default).

Europe options:

- 1.0 to 10.0 L/min (1.9 default);
- 1 to 8 hours (1 default).

1. Access the **Diagnostic** menu.
2. Using and , scroll to select the **Continuous flow** submenu.
3. Press to validate the selection.
4. Use or to activate the **Detection flow rate**.
5. Press to validate the activation.
 - ⇒ If **Off** is selected, the controller returns to the **Diagnostic** menu.
 - ⇒ If **On** is selected, the controller displays the **Detection flow** submenu.
6. Use and to set the **Detection flow**.
7. Press to validate the selection.
 - ⇒ The controller displays the **Detection time** submenu.
8. Use and to set the **Detection time**.
9. Press to validate the setting.
 - ⇒ The controller returns to **Diagnostics** menu.

Continuous submenu

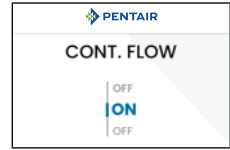

Detection flow

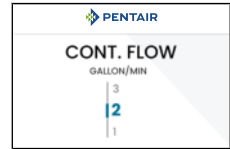

Detection time

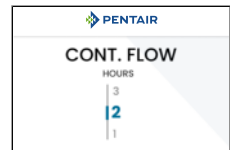

6.5.2.10 Emergency regeneration

Set the emergency regeneration.

Options:

- On (default);
- Off.

1. Access the **Diagnostic** menu.
2. Using and , scroll to select the **Emergency regeneration** submenu.
3. Press to validate the selection.
4. Use or to set the emergency regeneration.
5. Press to validate the setting.
 - ⇒ The controller returns to the **Diagnostics** menu.

Emergency regeneration submenu

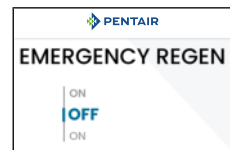







6.5.2.11 Restore backup

Restore a previous backup.

Options:

- List of available backups (last 3 settings).

1. Access the **Diagnostic** menu.
2. Using  and , scroll to select the **Restore backup** submenu.
3. Press  to validate the selection.
4. Use  and  to select the desired backup in the list.
5. Press  to validate the selection.

⇒ After restoring, the controller returns to the **Home** menu.

Restore backup submenu

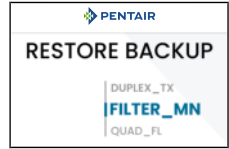



6.5.2.12 System version

Check the system version.

Information displayed:

- Firmware version;
- Hardware version.

1. Access the **Diagnostic** menu.
2. Using  and , scroll to select the **System version** submenu.
3. Press  to return to the **Diagnostics** menu.

System version submenu



6.5.3 Date/Time setting menu

6.5.3.1 Date/Time setting menu programming chart

| Parameter description | Range of values | Default value | Units of measure | Notes |
|-----------------------|--|---------------|------------------|--|
| Daylight Savings | Auto Off | Auto | - | The time of day adapts automatically to summertime and standard time. The time zone must be selected according to installation location. |
| Location | Europe North America Paraguay Chile New Zealand Australia | North America | - | Only displayed if Daylight Saving is set to Auto. |
| Time | 1:00 - 12:59 AM/ PM | 12:00 AM | Hour: Minute | US unit setting. |
| | 0:00 - 23:59 | 00:00 | | Metric unit setting. |
| Date | mm/dd/yyyy | Jan 01 2025 | - | - |

6.5.3.2 Daylight savings









Set the daylight savings.

Options:

- Auto (default);
- Off.

Location options:

- Europe;
- North America (default);
- Paraguay;
- Chile;
- New Zealand;
- Australia.

1. Access the **Day/Time** menu.
2. Using  and , scroll to select the **Daylight saving** submenu.
3. Press  to validate the selection.
4. Use  or  to select the desired option.
5. Press  to validate the selection.
 - ⇒ If **Off** is selected, the controller returns to **Day/Time** menu.
 - ⇒ If **On** is selected, the controller displays the **Location** submenu.
6. Using  and , scroll through the possible locations to select the one for installation.
7. Press  to validate the selection.
 - ⇒ The controller returns to **Date/Time** menu.

Daylight saving

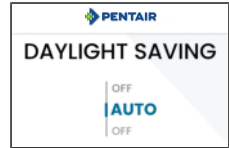

Location



6.5.3.3 Time







Set the time of day.

US and UK options:

- 01:00 AM to 12:25 PM (12:00 AM default).

Metric options:

- 00:00 to 24:00 (00:00 default).

1. Access the **Date/Time** menu.
2. Using  and , scroll to select the **Time** submenu.
3. Press  to validate the selection.
4. Use  and  to set the time hour.
5. Press  to validate the hour setting.
6. Repeat the previous two steps to set the minutes.
 - ⇒ Once the **Time** is set, controller returns to **Date/Time** menu.

Time submenu

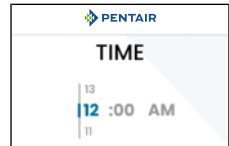

6.5.3.4 Date

Set the date mm/dd/yyyy.

Options:



- mm

| | | | |
|------|------|------|------|
| Jan; | Apr; | Jul; | Oct; |
| Feb; | May; | Aug; | Nov; |
| Mar; | Jun; | Sep; | Dec. |

- dd
01 to 31.

- yyyy
2025 to 9999.

1. Access the **Date/Time** menu.

2. Using  and , scroll to select the **Date** submenu.

3. Press  to validate the selection.

4. Use  and  to set the month.

5. Press  to validate month setting.

6. Repeat the previous two steps once to set the day and a second time to set the year.

⇒ Once the **Date** is set, controller returns to **Date/Time** menu.

Date submenu

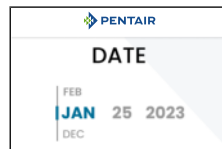

6.5.4 Contact setting menu

Info



This menu is not visible in all Fleck by default, it should be activated with the customized table.

6.5.4.1 Contact setting menu programming chart

| Parameter description | Range of values | Default value | Units of measure | Notes |
|-----------------------|-----------------|----------------|------------------|----------------------|
| Name 1 | A - Z | Free-from text | - | Up to 12 characters. |
| Name 2 | A - Z | Free-from text | - | Up to 12 characters. |
| Phone # | + 0 - 9 | Free-from text | - | Up to 14 digits. |

6.5.4.2 Name 1

Mandatory



All the digits of Name 1 must be set!

Use a space for empty digits.

Set the Name 1 to display.

Options:

- Space;
- A to Z.

1. Access the **Contact** menu.

2. Using and , scroll to select the **Name 1** submenu.

3. Press to start entering the name.

4. Use and to set the 1st name digit.

5. Press to validate the 1st name digit setting.

6. Repeat the previous two steps to set all the digits in the line.

⇒ When **Name 1** is set, controller returns to **Contact** menu.

Name 1 submenu



6.5.4.3 Name 2

Mandatory









All the digits of Name 2 must be set!

Use a space for empty digits.

Set the Name 2 to display.

Options:

- Space;
 - A to Z.
1. Access the **Contact** menu.
 2. Using  and , scroll to select the **Name 2** submenu.
 3. Press  to start entering the name.
 4. Use  and  to set the 1st name digit.
 5. Press  to validate the 1st name digit setting.
 6. Repeat the previous two steps to set all the digits in the line.
 - ⇒ When **Name 2** is set, controller returns to **Contact** menu.

Name 2 submenu

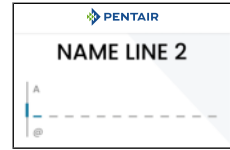

6.5.4.4 Phone

Mandatory









All the digits of Phone must be set!

Use a space for empty digits.

Set the phone number to display.

Options:

- Space;
 - +;
 - 0 to 9.
1. Access the **Contact** menu.
 2. Using  and , scroll to select the **Phone** submenu.
 3. Press  to start entering the phone number.
 4. Use  and  values to set the 1st phone digit.
 5. Press  to validate the 1st phone digit setting.
 6. Repeat the previous two steps to set all the digits in the line.
 - ⇒ When **Phone** is set, controller returns to **Contact** menu.

Phone submenu

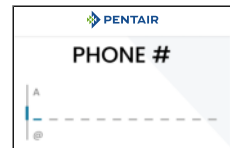

6.5.5 Cycle setting menu

6.5.5.1 Cycle setting menu programming chart

Info



Cycle time sequence depends on regeneration mode programming.

| Parameter description | Range of values | Default value | Units of measure | Notes |
|-----------------------|---|---------------|------------------|-------------------------|
| Cycle type | Filter Down flow Custom AIO Upflow | Filter | - | - |
| Backwash time | 0 to 240 | 10 | minute | Increments of 1 minute. |
| Draw time | 0 to 240 | 60 | minute | Increments of 1 minute. |
| Pause | 0 to 240 | 0 | minute | Increments of 1 minute. |
| Fast rinse time | 0 to 240 | 10 | minute | Increments of 1 minute. |
| Refill time | 0 to 240 | 10 | minute | Increments of 1 minute. |
| Pause | 0 to 240 | 15 | minute | Increments of 1 minute. |
| Custom | Add step Step 1 to n Remove last step | Add step | - | - |
| Step position | Draw Fast rinse Refill Pause Backwash | Brine draw | minute | - |
| Step time | 0 to 240 | 0 | minute | Increments of 1 minute. |







6.5.5.2 Cycle setting menu access

Info



Access to this menu is locked and can be protected by a passcode.

Refer to Lock settings [→Page 111].

1. If necessary, press  to return to the **Home** menu.
2. Press  +  for 2 seconds to unlock the menu access.
 - ⇒ If passcode is not set, **Cycle, Settings, System** and **Regeneration** menus are now displayed.
 - ⇒ If passcode is set, enter the passcode.
3. Use  and  to set the 1st passcode digit.
4. Press  to validate the 1st passcode digit setting.
 - ⇒ 0000 default.
5. Repeat the two previous steps to set the next three passcode digits.
 - ⇒ When last digit is validated, controller returns to **Home** menu and **Cycle, Settings, System** and **Regeneration** menus are now displayed.

Enter passcode submenu



6.5.5.3 Cycle

Set the cycle type and regeneration cycle times.

Cycle type options:











- Filter (default);
- Down flow;
- Up flow;
- Custom;
- AIO;
- Upflow.

Step position options:

- Backwash (default);
- Draw;
- Pause;
- Fast rinse;
- Refill;
- Pause.

Step time option:

- 0 to 240 minutes (default depends on regeneration cycle).

1. Access the **Cycle** menu.
2. Using  and , scroll to select the desired **Cycle type** submenu.
3. Press  to validate the selection.
 - ⇒ If **Down flow, Up flow, AIO** or **Filter** is selected, the controller displays the Cycle type submenu.
 - ⇒ If **Custom** is selected, refer to **Custom cycles** [→Page 103].
4. Using  and , scroll to select the **Regeneration cycle** to be set.
5. Press  to validate the selection.
 - ⇒ The controller displays the **Selected cycle time** submenu.
6. Use  and  to set the step time.
7. Press  to validate the setting.
 - ⇒ The controller returns to **Cycle type** submenu.
8. Repeat the four previous steps as needed.
9. Press  to return to **Cycle** menu.

Cycle menu

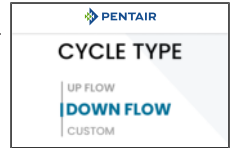

Cycle type submenu

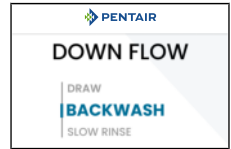

Backwash time



Draw time



Fast rinse time

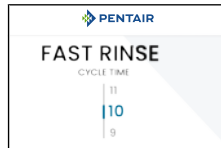

Refill time



6.5.5.4 Custom cycles

Set a custom regeneration.

Custom options:

- Add step (default);
- Step 1 to step n;
- Remove last step.

Step position options:

- Draw (default);
- Backwash;
- Pause;
- Refill;
- Fast rinse.

Step time option:

- 0 to 240 minutes (0 default).

1. Access the **Cycle** menu.
2. Using and , scroll to select the **Custom** submenu.
3. Press to validate the selection.
 - ⇒ The controller displays the **Custom** submenu.
4. Use and to select the desired option.
5. Press to validate the selection.
 - ⇒ If **Add step** is selected, a new regeneration step is created and the controller displays the **Step n position** submenu for the new step;
 - ⇒ If **Step n** is selected, the controller displays the **Step n position** submenu for the selected step;
 - ⇒ If **Remove last step** is selected, the last step is erased. The controller stays in the **Custom** submenu.
6. Use and to set the regeneration step.
7. Press to validate the setting.
 - ⇒ The controller displays the **Step n time** submenu.
8. Use and to set the step time.
9. Press to validate the setting.
 - ⇒ The controller returns to the **Custom** submenu.
10. Repeat the six previous steps as needed.
11. Press to return to **Cycle** menu.

Cycle menu



Custom submenu

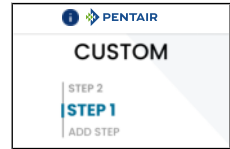

Step 1 position submenu

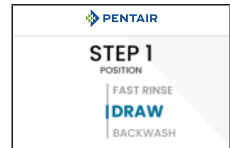

Step 1 time submenu

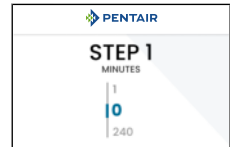

6.5.6 Settings menu

6.5.6.1 Settings menu programming chart

| Parameter description | Range of values | Default value | Units of measure | Notes |
|-----------------------|--|---------------|-------------------|---|
| Language | English Spanish Italian French German Dutch Polish | English | - | - |
| Unit Of Measure | US Metric Imperial (UK) | US | - | - |
| Hardness Unit | GPG | GPG | - | US or Imperial (UK) unit. Parameter not displayed. |
| | mg/L (PPM) °dH °TH | mg/L (PPM) | - | Metric unit. |
| Capacity | 0 – 1,000,000 | 300,000 | Grain | US unit setting. To be set in the programming tables. Increments of 1`000 unit. |
| | 0 – 70,000 | 19,400 | Gram | Metric unit setting. Increments of 100 units. |
| | 0 – 4,000 | 1,090 | °dHm ³ | Metric unit setting. Increments of 10 units. |
| | 0 – 7,000 | 1,940 | °THm ³ | Metric unit setting. Increments of 10 units. |

| Parameter description | Range of values | Default value | Units of measure | Notes |
|-----------------------|---|---------------|--------------------|--|
| Hardness | 0 – 200 | 20 | GPG | US unit setting. To be set in the programming tables. Increments of 1 unit. |
| | 10 – 3,400 | 340 | mg/L (PPM) | Metric unit setting. Increments of 10 units. |
| | 0 – 190 | 19 | °dH | Metric unit setting. |
| | 0 – 340 | 34 | °TH | Increments of 1 unit. |
| Salt Dosage | 3 – 18 | 9.0 | lb/ft ³ | US or UK unit setting. In Installer Setting menu, it is possible to adjust Salt dosage with increments of 0.1 lb/ft ³ of resin for more precise setting. |
| | 50 – 290 | 140 | g/L | Metric unit setting. In Installer Setting menu, it is possible to adjust Salt dosage with increments of 10 g/L of resin for more precise setting. |
| Resin Volume | 0.5 – 80 | 1 | ft ³ | US or UK unit setting. Increments of 0.5 units. |
| | 1 – 2300 | 28 | L | Metric unit setting. Increments of 1 unit. |
| Flow meter | Paddle (.75", 1", 1.5", 2", 3") Turbine (.75", 1.25", 1.5") Generic | Generic | - | - |
| Custom meter | 1 - 400 | 100 | Pulses/Gal | Displayed only if generic flow meter type has been selected. US or UK unit setting. Increments of 1 unit. |
| | 1 - 100 | 26 | Pulses/L | Displayed only if generic flow meter type has been selected. Metric unit setting. Increments of 1 unit. |

| Parameter description | Range of values | Default value | Units of measure | Notes |
|-----------------------|--------------------------|---------------|------------------|---|
| Lock setting | Off Delay Passcode | Off | - | - |
| Delay time | 10 – 360 | 10 | Min | Displayed only if delay in lock setting has been selected. |
| Enter passcode | 0000 – 9999 | 0000 | - | Displayed only if passcode in lock setting has been selected. |
| Change passcode | Yes No | Yes | - | Displayed only if the passcode has been entered correctly. |
| New passcode | 0000 - 9999 | 0000 | - | - |

6.5.6.2 Settings menu access

Info



Access to this menu is locked and can be protected by a passcode.

Refer to Lock settings [→Page 111].

- If necessary, press to return to the **Home** menu.
- Press + for 2 seconds to unlock the menu access.
 - ⇒ If passcode is not set, **Cycle, Settings, System** and **Regeneration** menus are now displayed.
 - ⇒ If passcode is set, enter the passcode.
- Use and to set the 1st passcode digit.
- Press to validate the 1st passcode digit setting.
 - ⇒ 0000 default.
- Repeat the two previous steps to set the next three passcode digits.
 - ⇒ When last digit is validated, controller returns to **Home** menu and **Cycle, Settings, System** and **Regeneration** menus are now displayed.

Enter passcode submenu









6.5.6.3 Language

Select the displayed language.

Options:

- English (Default);
- Spanish;
- Italian;
- French;

- German;
- Netherlands;
- Polish.

1. Access the **Settings** menu.
2. Using  and , scroll to select the **Language** submenu.
3. Press  to validate the selection.
 - ⇒ The controller displays the **Language** submenu.
4. Use  and  to select the desired language.
5. Press  to validate the selection.
 - ⇒ The controller returns to **Settings** menu.

Language submenu



6.5.6.4 Unit of measure

Select the unit of measure and, if metric, select the hardness unit.

Unit of measure options:

- US (default);
- Metric;
- Imperial (UK).

Metric hardness unit options:

Info



The hardness unit parameter is only displayed when selecting Metric.

If previous selection is US or imperial, hardness unit is automatically grains per gallon (GPG).

- mg/L (PPM) (default);
- °dH;
- °TH;

1. Access the **Settings** menu.
2. Using and , scroll to select the **Unit of measure** submenu.
3. Press to validate the selection.
 - ⇒ The controller displays the **Unit of measure** submenu.
4. Using and , scroll to select the desired unit of measure.
5. Press to validate the selection.
 - ⇒ If **US** or **Imperial** is selected, the controller returns to the **Settings** menu.
 - ⇒ If **Metric** is selected, the controller displays the **Hardness unit** submenu.
6. Use and to select the desired hardness unit.
7. Press to validate the selection.
 - ⇒ The controller returns to **Settings** menu.

Unit of measure submenu

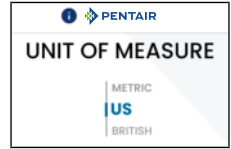

Hardness unit submenu

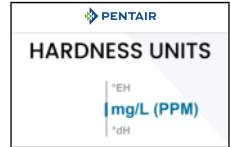

6.5.6.5 Capacity

Set the system capacity.

US options:

- 1 to 1,000,000 Grains (300,000 default).

Metric options:

- 0 to 70,000 g (19,400 default);
- 0 to 4,000 °dHm³/l (1,090 default);
- 0 to 7,000 °THm³/l (1,940 default);

1. Access the **Settings** menu.
2. Using and , scroll s to select the **Capacity** submenu.
3. Press to validate the selection.
 - ⇒ The controller displays the **Capacity** submenu.
4. Use and to set the present system capacity.
5. Press to validate the setting.
 - ⇒ The controller returns to **Settings** menu.

Capacity submenu

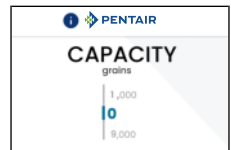

6.5.6.6 Hardness

Set the inlet water hardness. In case residual hardness at outlet is set using the internal mixing screw, deduct the measured residual hardness from inlet hardness for programming.

US options:

- 1 to 200 GPG (20 default).

Metric options:

- 10 to 3,400 mg/L (PPM) (340 default);
- 1 to 190 °dH (19 default);
- 1 to 340 °TH (34 default);

UK options:

- 1 to 200 GPG (20 default).

1. Access the **Settings** menu.

2. Using and , scroll to select the **Hardness** submenu.

3. Press to validate the selection.

⇒ The controller displays the **Hardness** submenu.

4. Use and to set the inlet water hardness.

5. Press to validate the setting.

⇒ The controller returns to **Settings** menu.

Hardness submenu

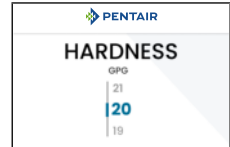

6.5.6.7 Salt dosage

Set the salt dosage.

US and UK options:

- 3 to 18 lb/ft³ (9.0 default).

Metric options:

- 50 to 290 g/L (140 default).

1. Access the **Settings** menu.

2. Using and , scroll to select the **Salt dosage** submenu.

3. Press to validate the selection.

⇒ The controller displays the **Salt dosage** submenu.

4. Use and to set the desired salt dosage.

5. Press to validate the setting.

⇒ The controller returns to **Settings** menu.

Salt dosage submenu

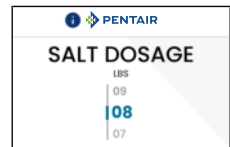

6.5.6.8 Resin volume







Set the system resin amount.

US and UK options:

- 0.25 to 7.00 ft³ (1 default);

Metric options:

- 1 to 200 L (28 default).

1. Access the **Settings** menu.
2. Using  and , scroll to select the **Resin volume** submenu.
3. Press  to validate the selection.
 - ⇒ The controller displays the **Resin volume** submenu.
4. Use  and  to set the actual resin amount.
5. Press  to validate the setting.
 - ⇒ The controller returns to **Settings** menu.

Resin volume submenu



6.5.6.9 Flow meter

Mandatory











For time clock regeneration mode, the flow meter must be set to none!

Set the flow meter.

Options:

- None;
- Paddle (.75", 1", 1.5", 2", 3");
- Turbine (.75", 1.25", 1.5");
- Generic.

1. Access the **Settings** menu.
2. Using  and , scroll to select the **Flow meter** submenu.
3. Press  to validate the selection.
 - ⇒ The controller displays the **Flow meter** submenu.
4. Use  and  to select the desired **Flow meter**.
5. Press  to validate the selection.
 - ⇒ If **None, turbine** or **paddle** is selected, the controller returns to the **Settings** menu.
 - ⇒ If **Generic** is selected, the controller displays the **Custom meter** submenu.
6. Use  and  to set the generic meter.
7. Press  to validate the setting.
 - ⇒ The controller returns to **Settings** menu.

Flow meter

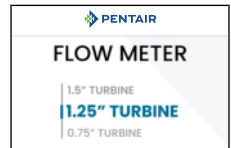

Custom meter submenu

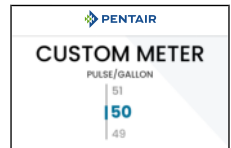

6.5.6.10 Lock settings

Lock settings.

Options:

- Off (Default)
Cycle type, settings, system and regeneration menus will be accessible all time;
- Delay
Cycle type, settings, system and regeneration menu access will be locked after delay;
- Passcode
Cycle type, settings, system and regeneration menu access will be locked with a passcode.

1. Access the **Settings** menu.

2. Using and , scroll to select the **Lock settings** submenu.

3. Press to validate the selection.

⇒ The controller displays the **Lock settings** submenu.

4. Use and to select the desired **Locking option**.

5. Press to validate the selection.

⇒ If **Off** is selected, the controller returns to the **Home** menu.

⇒ If **Delay** is selected, controller displays the **Delay time** submenu. Continue the procedure below with **Delay time**.

⇒ If **Passcode** is selected, controller displays the **Enter passcode** submenu. Continue the procedure with **Change passcode**.

Lock settings submenu

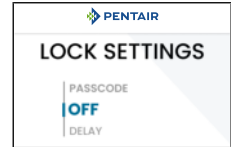

Delay submenu

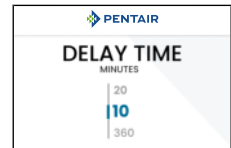

Enter passcode submenu



Delay time

Set the locking delay.

Options:

- 10 to 360 minutes (10 default).

1. Use and to set the **Lock delay**.

2. Press to validate the setting.

⇒ The controller returns to **Settings** menu.

Delay time submenu

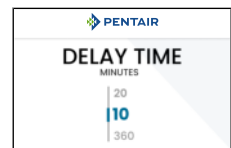









Passcode

Set a passcode.

Options:

- 0000 to 9999 (0000 default).

1. Use  and  to set the 1st passcode digit.
2. Press  to validate the 1st passcode digit setting.
3. Repeat the two previous steps to set the next three passcode digits.
 - ⇒ Once the last digit is validated, controller displays **Change code** submenu.
4. Use  or  to activate the **Passcode change**.
5. Press  to validate the activation.
 - ⇒ If **No** is selected, the controller returns to **Settings** menu.
 - ⇒ If **Yes** is selected, the controller displays the **New passcode** submenu.
6. Use  and  to set the 1st passcode digit.
7. Press  to validate the setting of the 1st passcode digit setting.
8. Repeat the two previous steps to set the next three passcode digits.
 - ⇒ Once the last digit is validated, the **New passcode** is set and controller returns to **Settings** menu.

Enter passcode submenu



Change code submenu



New passcode submenu



6.5.7 System setting menu

6.5.7.1 System setting menu programming chart

| Parameter description | Range of values | Default value | Units of measure | Notes |
|-----------------------|--------------------------------------|---------------|------------------|---|
| Push settings | Auto Off One time | Off | - | - |
| Remote regeneration | Immediate On delay On schedule | Immediate | - | Displayed only if in the settings menu the flow meter is set as none. |
| Delay time | 10 – 360 | 10 | Minute | Displayed only if on delay remote regeneration has been selected. |
| Trigger time | 1 – 30 | 1 | Second | Displayed only if on schedule remote regeneration has been selected. |

See also

Regeneration mode [Page 51]

6.5.7.2 System menu access

Info



Access to this menu is locked and can be protected by a passcode.

Refer to Lock settings [→Page 111].

- If necessary, press to return to the **Home** menu.
- Press + for 2 seconds to unlock the menu access.
 - ⇒ If passcode is not set, **Cycle, Settings, System** and **Regeneration** menus are now displayed.
 - ⇒ If passcode is set, enter the passcode.
- Use and to set the 1st passcode digit.
- Press to validate the 1st passcode digit setting.
 - ⇒ 0000 default.
- Repeat the two previous steps to set the next three passcode digits.
 - ⇒ When last digit is validated, controller returns to **Home** menu and **Cycle, Settings, System** and **Regeneration** menus are now displayed.

Enter passcode submenu



6.5.7.3 Remote regeneration

Info



This parameter is displayed only if, in settings menu, flow meter is set to none.

In time clock mode, the regeneration can also be triggered via a remote dry contact signal. In this case, remote regeneration should be set to On and the remote signal set to the desired duration (1-30 seconds).

Set the remote regeneration.

Remote regeneration options:

- Immediate (default);
- On delay;
- On schedule.

Trigger delay options:

- 1 to 30 seconds (1 default).

Delay options:

- 10 to 360 minutes (10 default).

1. Access the **System** menu.
2. Using and , scroll to select the **Remote regeneration** submenu.
3. Press to validate the selection.
 - ⇒ The controller displays the **Remote regeneration** submenu.
4. Use and to select the desired remote regeneration.
5. Press to validate the selection.
 - ⇒ If **Immediate** is selected, the regeneration will begin as soon as it is triggered.
 - ⇒ If **Delay** is selected, regeneration, when triggered, will start after the set delay time.
The controller displays the **Trigger time** submenu.
 - ⇒ If **On schedule** is selected, regeneration will start at the next regeneration window.
6. Use and to set the desired trigger time.
7. Press to validate the setting.
 - ⇒ If **Immediate** or **On schedule** is selected, the controller returns to **System** menu.
 - ⇒ If **Delay** is selected, the controller displays the **Delay time** submenu.
8. Use and to set the desired delay time.
9. Press to validate the setting.
 - ⇒ The controller returns to the **System** menu.

Remote regeneration submenu

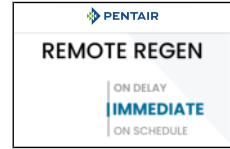

Trigger time submenu



Delay time submenu

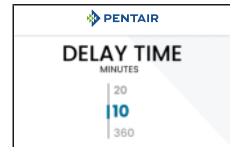

6.5.8 Regeneration setting menu

6.5.8.1 Regeneration setting menu programming chart







| Parameter description | Range of values | Default value | Units of measure | Notes |
|-----------------------|--|---------------|------------------|--|
| Regen Type | Meter Delayed Meter Immediate TC Day of the Week Time Clock | Meter Delayed | - | Regeneration triggered by time or volume. |
| Regeneration days | Monday Tuesday Wednesday Thursday Friday Saturday Sunday | All | - | Displayed only if the time clock day of the week regeneration mode is selected. The regeneration starts at the regeneration time. i.e. 2:00 am on the days set. |
| Regeneration time | 1:00 - 12:59 AM/ PM | 1:00 AM | Hour: Minute | US unit setting. |
| | 0:00 - 23:59 | 02:00 | | Metric unit setting. |
| Day Override | Off 0 to 100 | 30 | Day | Displayed only if time clock regeneration mode is selected. Number of days since last regeneration in which a new regeneration will automatically be run whether one is scheduled or not. |

| Parameter description | Range of values | Default value | Units of measure | Notes |
|-----------------------|---|------------------|---|--|
| Reserve Type | Variable Reserve | Variable Reserve | Gal L | Only displayed if meter delay regeneration mode is select. Daily updated based upon the real water consumption taking into account the day of week over the past 4 weeks history of daily water consumptions. |
| | Variable Reserve – Day of the week | | | Only displayed if meter delayed regeneration mode is selected. |
| | Fixed Volume 0 to 300,000 0 to 1,000,000 | | Only displayed if meter delayed regeneration mode is selected. Max 50% of the volume capacity. | |
| | Fixed Percent 0 to 50 | | % | Only displayed if meter delayed regeneration mode is selected. Increments of 1 unit. |
| Regeneration out | Off On | Off | - | - |
| Start-up sequence | Off On | Off | - | - |
| Step selection | Add step Step 1 ... Step n Remove last step | Add step | - | - |
| Step definition | Draw Fast rinse Refill Pause Backwash | Draw | - | - |
| Step time | 0 – 240 | 0 | Minute | - |

6.5.8.2 Regeneration type

Select and set the regeneration initiation mode.

Regeneration options:

- delayed (default);
 - immediate.
1. Access the **Regeneration** menu.
 2. Using  and , scroll to select the **Regeneration type** submenu.
 3. Press  to validate the selection.
 - ⇒ The controller displays the **Regeneration type** submenu.
 4. Use  and  to select the desired option.
 5. Press  to validate the selection.
 - ⇒ The controller returns to the **Regeneration** menu.

Regeneration type submenu

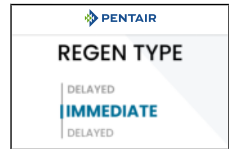

6.5.8.3 Regeneration days

Info



Regeneration days is displayed only if regeneration type is set to time clock day of the week.

Mandatory



In time clock day of the week mode, at least one day must be set to on!

When this mode is selected, all days are selected by default (check mark). The regeneration starts at the programmed regeneration time for each activated days of the week.

Day override parameter is ignored when time clock day of the week is selected.

Activate/deactivate regeneration initiation for each day.

Regeneration days options:

- Monday;
- Tuesday;
- Wednesday;
- Thursday;
- Friday;
- Saturday;
- Sunday.

1. Access the **Regeneration** menu.
2. Using and , scroll to select the **Regeneration days** submenu.
3. Press to validate the selection.
 - ⇒ The controller displays the **Regeneration days** submenu.
4. Use and to select the desired option for the selected day.
 - ⇒ A check mark will indicate that the day has been selected for regeneration.
5. Press to validate the selection and pass to the next day.
6. Repeat the previous two steps for all days.
 - ⇒ Once all days are set, the controller returns to **Regeneration** menu.

Regeneration days submenu



6.5.8.4 Regeneration time

Set the time of day.

US and UK options:

- 01:00 AM to 12:25 PM (2:00 AM default).

Metric options:

- 00:00 to 24:00 (02:00 default).

1. Access the **Regeneration** menu.
2. Using and , scroll to select the **Regeneration time** submenu.
3. Press to validate the selection.
 - ⇒ The controller displays the **Regeneration time** submenu.
4. Use and to set the time hour.
5. Press to validate the hour setting.
6. Repeat the previous two steps to set the time minutes.
 - ⇒ Once the **Regeneration time** is set, the controller returns to the **Regeneration** menu.

Regeneration time submenu

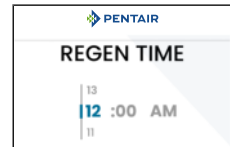

6.5.8.5 Day override

Info



This parameter is not displayed when selecting Time clock day of the week regeneration.

Set the maximum durations (days) between two regenerations before the **Day override** regeneration is booked.

- Off;

- 1 to 100 days (30 days by default).
- 1. Access the **Regeneration** menu.
- 2. Using and , scroll to select the **Day override** submenu.
- 3. Press to validate the selection.
 - ⇒ If **Variable** or **Weekly reserve** is selected, the controller returns to **Regeneration** menu.
- 4. Use and to set the number of days.
- 5. Press to validate the setting.
 - ⇒ The controller returns to **Regeneration** menu.

Day override submenu

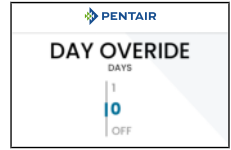

6.5.8.6 Reserve type

Info



Reserve type is displayed only if meter delayed regeneration mode is selected.

Select and set the reserve type.

Reserve type options:

- Variable reserve - Day of week;
- Variable reserve (default);
- Fixed volume; Calculated (max 50% of the volume capacity);
- Fixed percent.

US setting options:

- Volume: 0 to 300,000 Gal (3,000 default);
- Percent 0 to 50% (20 default).

US setting options:

- Volume: 0 to 1,000,000 L (10,000 default);
- Percent 0 to 50% (20 default).

1. Access the **Regeneration** menu.
2. Using and , scroll to select the **Reserve type** submenu.
3. Press to validate the selection.
 - ⇒ The controller displays the **Reserve type** submenu.
4. Use and to select the desired reserve type.
5. Press to validate the selection.
 - ⇒ If **Variable reserve** is selected, the controller returns to **Regeneration** menu.
 - ⇒ If **Volume** or **percent** is selected, the controller displays the **Reserve volume** or **Reserve percent** submenu.
6. Use and to set the reserve.
7. Press to validate the setting.
 - ⇒ The controller returns to the **Regeneration** menu.

Reserve type submenu



Reserve volume submenu



Reserve percent submenu



6.5.8.7 Regeneration lock

Lock regeneration.

Options:

- Off (default);
- On.

1. Access the **Regeneration** menu.
2. Using and , scroll to select the **Regeneration lock** submenu.
3. Press to validate the selection.
 - ⇒ The controller displays the **Regeneration lock** submenu.
4. Use and to select the desired option.
5. Press to validate the selection.
 - ⇒ The controller returns to **Regeneration** menu.

Regeneration lock submenu



6.5.8.8 Startup sequence

Set a custom startup sequence.

Startup sequence options:

- Off (default);

- On.

Startup sequence options:

- Add step (default);
- Step 1 to step n;
- Remove last step.

Step position options:

- Draw (default);
- Backwash;
- Pause;
- Refill;
- Fast rinse.

Step time option:

- 0 to 240 minutes (0 default).

1. Access the **Regeneration** menu.
2. Using and , scroll to select the **Startup sequence** submenu.
3. Press to validate the selection.
 - ⇒ The controller displays the **Startup sequence** submenu.
4. Use and to select the desired option.
5. Press to validate the selection.
 - ⇒ If **Off** is selected, the controller returns to the **Regeneration** menu.
 - ⇒ If **On** is selected, the controller displays the **Startup step** submenu.
6. Use and to select the desired option.
7. Press to validate the selection.
 - ⇒ If **Add step** is selected, a new regeneration step is created and the controller displays the **Step n position** submenu for the new step;
 - ⇒ If **Step n** is selected, the controller displays the **Step n position** submenu for the selected step;
 - ⇒ If **Remove last step** is selected, the last step is erased. The controller stays in the **Startup step** submenu.
8. Use and to set the regeneration step.
9. Press to validate the setting.
 - ⇒ The controller displays the **Step n time** submenu.
10. Use and to set the step time.
11. Press to validate the setting.
 - ⇒ The controller returns to the **Start up** submenu.
12. Repeat the six previous steps as needed.
13. Press to return to **Regeneration** menu.

Startup sequence submenu



Startup step submenu

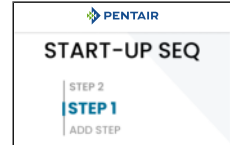

Step 1 position submenu

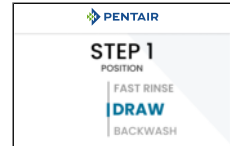



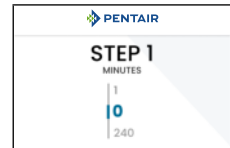



Step 1 time submenu



6.6 Reset

Reset the controller.

Reset options:

- Reset lock (unlock the controller);
 - Full reset (data and settings).
1. Unplug from the power source.
 2. Plug in the controller in the power source.
 - ⇒ The controller displays the boot screen.
 3. While the boot screen is displayed, press  + .
 - ⇒ The controller displays the **Reset** menu.
 4. Using  and , scroll to select the desired **Test** or **Reset** option.
 5. Press  to validate the selection.
 - ⇒ The controller displays the selected option screen.
 6. Press  to start **Test** or **Reset**.
 - ⇒ Once the **Test** or the **Reset** is done, the controller returns to the **Reset** menu.
 7. From the **Reset** menu, press  to display the **Home** menu.

Boot screen



Reset lock screen



Full reset screen

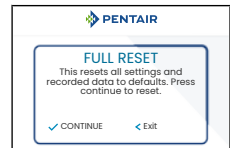

7 Commissioning















Info



This chapter is available for standard regeneration flows. Contact your supplier if the actual regeneration is not standard and if you need assistance.

7.1 Water filling, draining and waterproofness inspection

7.1.1 Activating a single valve system (System 4)

1. With the bypass still in **Bypass** position (inlet and outlet of the valve closed), plug in the AiQ controller to the power source.
2. Proceed to programming according to system specification if not done yet.
3. Press  +  to display the **Manual regeneration** menu. Use  and  to select the **Immediate** option. Press  twice to start a manual regeneration. The piston will move into **Backwash** position. Once in this position, unplug the AiQ controller from the power source.
4. With the outlet manual valve still closed, slowly open the inlet manual valve. The valve and tank will slowly get filled with raw water, allowing air to be purged by the drain. Open the inlet progressively until fully open position.
5. Once the drain runs clear and the inlet manual valve fully open, plug in again the AiQ controller to the power source.
6. Push on once  to move the piston to the next regeneration cycle position. Leave the valve 1 minute in each position and move to the next one, until **Tank refill** or **Pause** is displayed. When **Tank refill** or **Pause** is displayed, let the valve run the entire cycle and check the level of water in the brine tank. The level of water in the brine tank should be about 5 cm above the salt platform. You may want to mark the level on the brine tank as this can be used as an indicator for the future lifetime of the softener.
7. Once the **Tank refill** or **Pause** cycle is completed, the valve will automatically go back into service position (unless non-standard regen sequence is programmed). Start again a manual regeneration by pressing  +  to display the **Manual regeneration** menu, using  and  to select the **Immediate** option and pressing  twice. The valve will move to **Backwash** position.
8. Press  once to move to **Draw** position. Check to see in the brine tank if the water level decreases.
9. Once the draw function is observed and confirmed (level of water in the brine tank has decreased), you may go through each cycle pushing on  until **Tank refill** or **Pause**, leave the water come back to the full level, and then push on  so that the valve returns into service position.
10. Slowly open the outlet manual valve, and close the bypass manual valve. The system is now in service.

11. Fill the brine tank with salt. You may want to mark the level of water in the brine tank when completely refilled with water and full of salt. In the future, after each regeneration, you can visually control that the quantity of water refilled should be between the 2 marks done. Marking is optional, but may allow to visually detect an irregularity during regeneration that may lead to softener inefficiency.
12. With the brine tank completely refilled and full of salt, adjust the safety brine valve in the brine well. Make sure the overflow elbow is installed above the float level and the discharge point.
13. After the softener has been running a few minutes in service, proceed to hardness test on outlet water to make sure the water is treated as per requirements.

7.2 Sanitization

7.2.1 Disinfection of water softeners

The materials of construction of the modern water softener will not support bacterial growth, nor will these materials contaminate a water supply. In addition, during normal use, a softener may become polluted with organic matter, or in some cases with bacteria from the water supply. This may result in an off-taste or odour in the water.

Thus, the softener may need to be disinfected after installation. Some softeners will require periodic disinfection during their normal lifetime. Consult the installing dealer for more information on softener disinfection.

Depending on the conditions of use, the softener type, the type of ion exchanger and the disinfectant available, a choice can be made among the following methods.

7.2.2 Sodium or calcium hypochlorite

These materials are satisfactory for use with polystyrene resins, synthetic gel zeolite, greensand and bentonites.

5.25% Sodium hypochlorite

If stronger solutions are used, such as those sold for commercial laundries, adjust the dosage accordingly.

Dosage

- **For Europe**
 - Polystyrene resin: set 1.25 ml fluid per 1 L of resin.
 - Non-resinous exchangers: set 0.85 ml fluid per 1 L.
- **For US**
 - Polystyrene resin: set 1.2 fluid ounce (35.5 ml) per ft³.
 - Non-resinous exchangers: set 0.8 fluid ounce (23.7 ml) per ft³.

Brine tank softeners

Backwash the softener and add the required amount of hypochlorite solution to the well of the brine tank. The brine tank should have water in it to permit the solution to be carried into the softener.

Proceed with the normal regeneration.

Calcium hypochlorite

Calcium hypochlorite, 70% available chlorine, is available in several forms including tablets and granules. These solid materials may be used directly without dissolving before use.

Do not let the disinfectant stand for more than 3 hours in the brine tank before the regeneration start.

Dosage

- **For Europe**
 - Measure two grains ~ 0.11 ml for 1 l.
- **For US**
 - Measure two grains ~ 0.1 ounce (3 ml) per ft³.

Brine tank softeners

Backwash the softener and add the required amount of hypochlorite to the well of the brine tank. The brine tank should have water in it to permit the chlorine solution to be carried into the softener.

Proceed with the normal regeneration.

8 Operation

8.1 Display

8.1.1 During service

If left untouched for 5 minutes, the display shows the following service information every 5 seconds on a dark grey background:

Time and date:



Status and remaining capacity:



Current and peak flows (displayed only if flow meter is set as turbine):



Contact:



Pressing either button brings up the home menu. The lower left-hand corner displays the following information every 5 seconds:

Time and date:

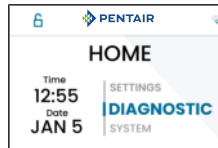

Status and remaining capacity:

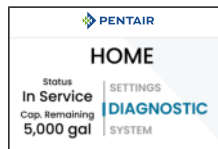

Current and peak flows (displayed only if flow meter is set as turbine):

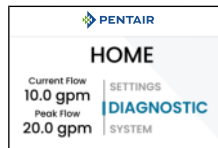

Contact:

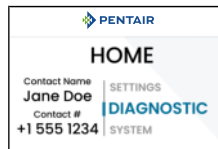

8.1.2 During regeneration

The display shows the current cycle with time remaining. Here are some examples:

Backwash cycle:

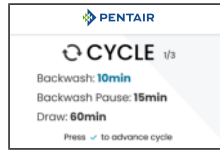

Rapid rinse cycle:



Tank refill cycle:



8.2 Recommendations

- Use only regeneration salts designed for water softening EN 973;
- for optimal system operation, the use of clean salt and impurities free is recommended (for example salt pellets);
- do not use ice melt salt, block, or rock salts;
- the sanitizing process may introduce chlorine compounds which may reduce the life of the ion exchange resins. Refer to media manufacturer specifications sheet for more information.

8.3 Manual regeneration

Mandatory



The controller must be in service in order to enable this procedure!

8.3.1 Manual regeneration menu structure and navigation

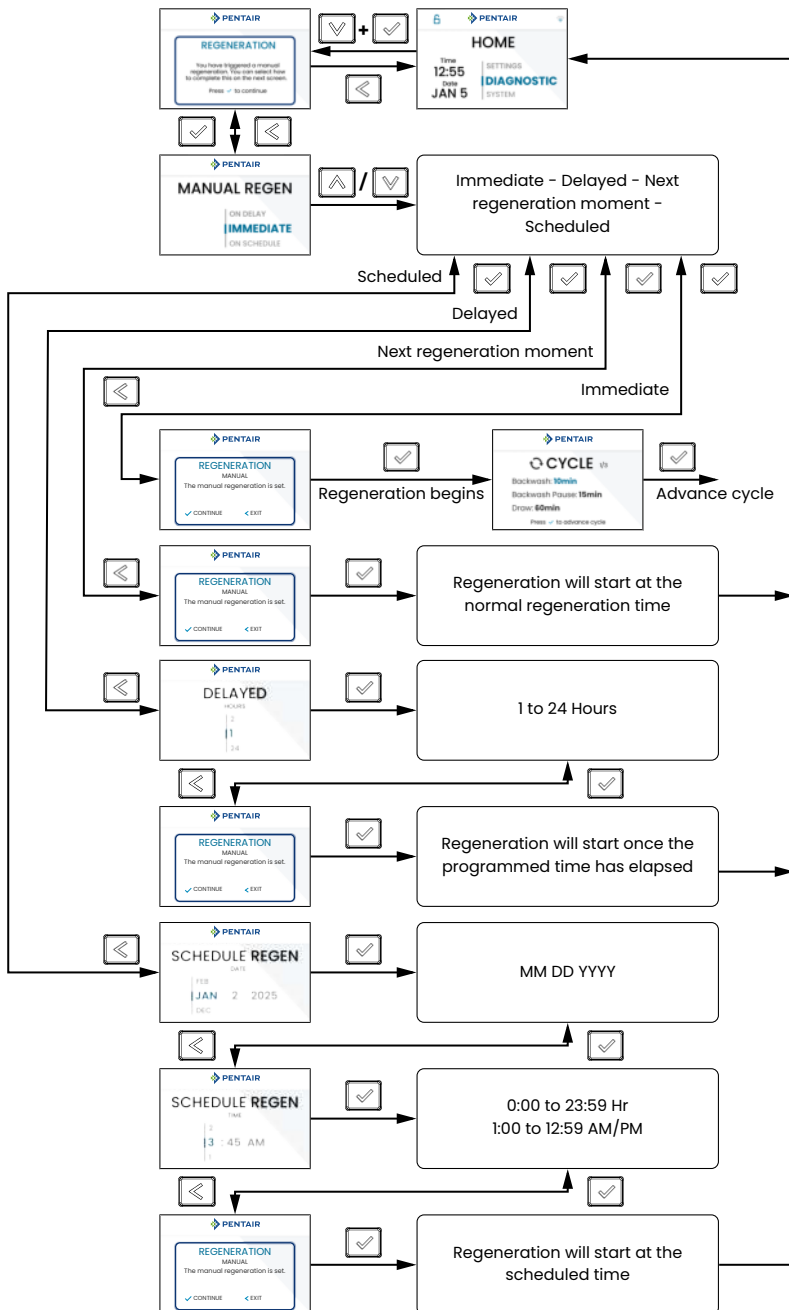

- + enters the **Manual regeneration** menu from the **Home** menu and permits to set the various **Manual regeneration** submenus.
- displays **Previous** option.
- displays **Next** option.
- returns to previous menu. Pressed for 2 seconds, returns to the **Home** menu.

Manual regeneration menu allows to initiate an immediate regeneration or manage booking of a delayed regeneration.

8.3.2 Trigger an immediate regeneration

1. From **Home** menu, press + .
 - ⇒ The controller displays the **Manual regeneration** screen.
2. Press to enter the **Manual regeneration** menu.
3. Using and , scroll to select the **Immediate** option.
4. Press to validate the selection.
 - ⇒ The controller displays the **Regeneration set** screen.
5. Press to validate the **Immediate** regeneration.
 - ⇒ The regeneration begins and the controller displays the **Regeneration cycle** screens.

Manual regeneration screen



Manual regeneration menu





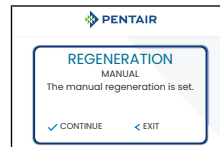



Regeneration set screen



First regeneration cycle screen



8.3.3 Trigger a regeneration at next regeneration moment

1. From **Home** menu, press  + .
 - ⇒ The controller displays the **Manual regeneration** screen.
2. Press  to enter the **Manual regeneration** menu.
3. Using  and , scroll to select the **Next regeneration moment** option.
4. Press  to validate the selection.
 - ⇒ The controller displays the **Regeneration set** screen.
5. Press  to validate the **Next regeneration moment** regeneration.
 - ⇒ The controller returns to the **Home** menu and the regeneration will start at the normal regeneration time.

Manual regeneration screen

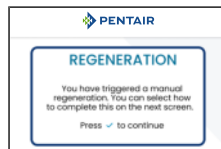

Manual regeneration menu

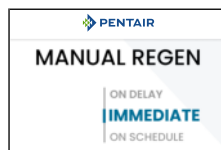



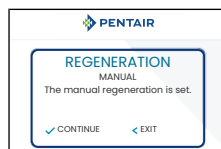







Regeneration set screen



8.3.4 Trigger a delayed regeneration

Option:

- 1 -24 hours (1 default).

1. From **Home** menu, press  + .
 - ⇒ The controller displays the **Manual regeneration** screen.
2. Press  to enter the **Manual regeneration** menu.
3. Using  and , scroll to select the **Delayed** option.
4. Press  to validate the selection.
 - ⇒ The controller displays the **Delayed** submenu.
5. Use  and  to set the delay time.
6. Press  to validate the selection.
 - ⇒ The controller displays the **Regeneration set** screen.
7. Press  to validate the **Delayed** regeneration.
 - ⇒ The controller returns to the **Home** menu and the regeneration will start once the programmed time has elapsed.

Manual regeneration screen

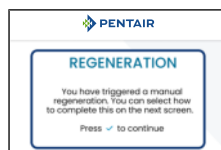

Manual regeneration menu

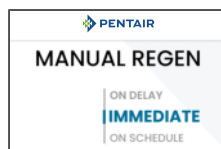

Delayed submenu

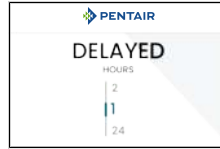

Regeneration set screen



8.3.5 Trigger scheduled regeneration

Date option:

- mm

| | | | |
|------|------|------|------|
| Jan; | Apr; | Jul; | Oct; |
| Feb; | May; | Aug; | Nov; |
| Mar; | Jun; | Sep; | Dec. |

- dd
01 to 31.













- yyyy
2025 to 9999.

US and UK time options:

- 01:00 AM to 12:25 PM (12:00 AM default).

Metric time options:

- 00:00 to 24:00 (00:00 default).

1. From **Home** menu, press  + .
 - ⇒ The controller displays the **Manual regeneration** screen.
2. Press  to enter the **Manual regeneration** menu.
3. Using  and , scroll to select the **Scheduled** option.
4. Press  to validate the selection.
 - ⇒ The controller displays the **Scheduled date** submenu.
5. Use  and  to set the month.
6. Press  to validate month setting.
7. Repeat the previous two steps once to set the day and a second time to set the year.
 - ⇒ Once the **Date** is set, the controller displays the **Scheduled time** submenu.
8. Use  and  to set the time hour.
9. Press  to validate the hour setting.
10. Repeat the previous two steps to set the minutes.
 - ⇒ Once the **Time** is set, the controller displays the **Regeneration set** screen.
11. Press  to validate the **Scheduled** regeneration.
 - ⇒ The controller returns to the **Home** menu and the regeneration will start at the scheduled time.

Manual regeneration screen



Manual regeneration menu



Scheduled date submenu

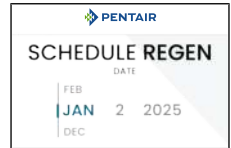

Scheduled time submenu

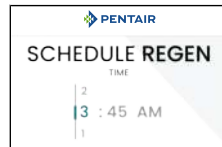

Regeneration set screen

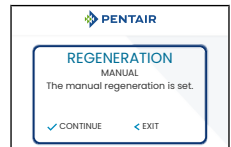

8.3.6 To advance regeneration cycles

1. Press  to skip to the next regeneration cycle.

8.4 Operation during a power failure

- All the program settings are stored in a permanent memory;
- current valve position, cycle step time elapsed, and time of day are stored during a power failure, and will be restored upon power restoration;
- time is kept during a power failure and the time of day is adjusted upon restoration of the power (as long as the power is restored within 48 hours);
- the time of day on the main display screen will flash after a power failure once the power is restored until any button is pressed on the keyboard.

9 Maintenance

Mandatory



Cleaning, maintenance and service operation shall take place at regular intervals and must be done by qualified personnel only in order to guarantee the proper functioning of the complete system.

Report maintenance done in the Maintenance chapter of the User Guide document.

Failure in respecting above instructions may void the warranty!

9.1 General system inspection

Mandatory



Must be done, at minimum, once a year !

9.1.1 Water quality

9.1.1.1 Valve used for softening

1. Raw water total hardness.
2. Treated water hardness.

9.1.1.2 Valve used for filtration

1. Check for raw water analysis and filter's targeted contaminants concentration.
2. Check for treated water analysis and compare with raw water data.

9.1.2 Mechanical checks

1. Inspect general condition of softener/filter and associated ancillaries and check for any leaks, ensure valve connection to piping is made with adequate flexibility as per manufacturer instruction.
2. Inspection of electrical connections, verify wiring connections and search for evidence of overloading.
3. Verify settings of electronic timer, verify regeneration frequency, and make sure the valve configuration is appropriate for media and tank size.
4. Check water meter, if present, report water meter settings and compare with previous inspection.
5. If water meter is present, verify total water consumption compared to previous visit.
6. If pressure gauges are installed before and after softening/filtering system, verify and record static and dynamic pressure, reporting pressure drop. Verify that inlet pressure respects valve and softening/filtering system limits. Verify that pressure drop stay stable year on year, adapt backwash duration if required.
7. If pressure gauges are not present, but suitable points exist, install temporary pressure gauge(s) to perform precedent point.

9.1.3 Regeneration test

9.1.3.1 Valve used for softening

1. Check condition of brine tank and any associated equipment.
2. Check salt level in brine tank.
3. Initiate regeneration test.
 - ⇒ Check brine draw during brine draw stage.
 - ⇒ Check brine tank refill.
 - ⇒ Check operation of safety brine valve, where fitted.
 - ⇒ Check for brine draw off levels.
 - ⇒ Check for resin loss at the drain during regeneration.
 - ⇒ Where fitted, check for satisfactory operation of solenoid, i.e. outlet shut off during regeneration and/or brine line shut off valve(s).
4. Test and record Total Hardness of outlet water from softener vessel(s).

9.1.3.2 Valve used for filtration

1. Initiate manual regeneration and observe flow to drain.
2. Make sure flow rate correspond to DLFC configuration.
3. Check for media loss at the drain during backwash.
4. Check to see if water runs clear at the end of the backwash cycle.
5. Observe flow fast rinse cycle and measure pressure drop through the filter system. Pressure drop after fast rinse should return equal or very close to pressure drop recorded after system start-up.
6. Where fitted, check for satisfactory operation of solenoid valve(s) i.e. outlet shut off during regeneration.

9.2 Recommended maintenance plan

9.2.1 Valve used for softening

| Items | 1 year | 2 year | 3 year | 4 year | 5 year |
|---|---|---|---|---|---|
| Injector & filter | Clean | Clean | Clean | Clean | Clean/ replace if necessary |
| BLFC*** | Clean | Clean | Clean | Clean | Clean/ replace if necessary |
| DLFC*** | Clean | Clean | Clean | Clean | Clean/ replace if necessary |
| Bypass (if present, contains Orings***) | Clean | Clean | Clean | Clean | Clean/replace if necessary |
| Piston* | Check/clean/ replace if necessary | Replace | Check/clean/ replace if necessary | Replace | Check/clean/ replace if necessary |
| Seals & spacers* | Check/clean/ replace if necessary | Replace | Check/clean/ replace if necessary | Replace | Check/clean/ replace if necessary |
| Brine valve | Check/clean/ replace if necessary | Check/clean/ replace if necessary | Check/clean/ replace if necessary | Check/clean/ replace if necessary | Replace |
| O-rings*** | Check for watertightness /clean or replace in case of leakage | Check for watertightness /clean or replace in case of leakage | Check for watertightness /clean or replace in case of leakage | Check for watertightness /clean or replace in case of leakage | Check for watertightness /clean or replace in case of leakage |
| Motors | Check | Check | Check | Check | Replace |
| Gearing | Check | Check | Check | Check | Check/ replace if necessary |
| Inlet hardness | Check | Check | Check | Check | Check |
| Residual hardness | Check/adapt mixing screw if necessary | Check/adapt mixing screw if necessary | Check/adapt mixing screw if necessary | Check/adapt mixing screw if necessary | Check/adapt mixing screw if necessary |
| Electronic/ settings** | Check | Check | Check | Check | Check/ replace if necessary |
| Transformer** | Check | Check | Check | Check | Check/ replace if necessary |
| Optical sensor | Check | Check | Check | Check | Replace |
| Meter(s)* (if present) | Check and Clean | Check and Clean | Check and Clean | Check and Clean | Replace |
| Meter cable(s)* (if present) | Check | Check | Check | Check | Replace |

| Items | 1 year | 2 year | 3 year | 4 year | 5 year |
|--------------------------------|--------|--------|--------|--------|--------|
| Valve watertightness | Check | Check | Check | Check | Check |
| Valve to piping watertightness | Check | Check | Check | Check | Check |

* Wear parts - durability strongly affected by raw water quality and regeneration frequency.

** Electronic parts – durability strongly affected by power source quality and stability.

*** Elastomer durability is strongly affected by raw water concentration in chlorine and its derivative.

9.2.2 Valve used for filtration

| Items | 1 year | 2 year | 3 year | 4 year | 5 year |
|---|---|---|---|---|---|
| DLFC*** | Clean | Clean | Clean | Clean | Clean/ replace if necessary |
| Bypass (if present, contains Orings***) | Clean | Clean | Clean | Clean | Clean/replace if necessary |
| Piston* | Replace | Replace | Replace | Replace | Replace |
| Seals & spacers* | Replace | Replace | Replace | Replace | Replace |
| O-rings*** | Check for watertightness /clean or replace in case of leakage | Check for watertightness /clean or replace in case of leakage | Check for watertightness /clean or replace in case of leakage | Check for watertightness /clean or replace in case of leakage | Check for watertightness /clean or replace in case of leakage |
| Motors | Check | Check | Check | Check | Replace |
| Gearing | Check | Check | Check | Check | Check/ replace if necessary |
| Electronic/ settings** | Check | Check | Check | Check | Check/ replace if necessary |
| Transformer** | Check | Check | Check | Check | Check/ replace if necessary |
| Optical sensor | Check | Check | Check | Check | Replace |
| Microswitches | Check | Check | Check | Check | Replace |
| Meter(s)* (if present) | Check and Clean | Check and Clean | Check and Clean | Check and Clean | Replace |
| Meter cable(s)* (if present) | Check | Check | Check | Check | Replace |
| Valve watertightness | Check | Check | Check | Check | Check |
| Valve to piping watertightness | Check | Check | Check | Check | Check |

* Wear parts - durability strongly affected by raw water quality and regeneration frequency.

** Electronic parts – durability strongly affected by power source quality and stability.

*** Elastomer durability is strongly affected by raw water concentration in chlorine and its derivative.

9.3 Recommendations

9.3.1 Use original spare parts

Caution - material



Risk of damage due to use of non-genuine spare parts

To ensure correct operation and safety of the device, only use original spare parts and accessories recommended by the manufacturer.

Usage of non-genuine spare parts voids all warranties.

Parts to keep in stock for potential replacements are the pistons, S&S kit, injectors, micro-switches and motors. Refer to maintenance sheet.

9.3.2 Use original approved lubricants

- Dow corning #7 Release Agent;
- spare part: p/n 1014081 (NAM) – 42561 (EMEA), (SILICONE LUBRICANT PACK).

9.3.3 Maintenance instructions

- Disinfect and clean the system at least once a year or if the treated water has an off-taste or an unusual odor;
- perform a hardness test every year at both inlet and treated water.

9.4 Cleaning and maintenance

9.4.1 First steps

Before any cleaning or maintenance procedure, complete the following steps:

Mandatory



These operations must be performed before any cleaning or maintenance procedure!

1. Unplug the wall-mounted transformer.
2. Shut off water supply or put bypass valve(s) into bypass position.
3. Relieve system pressure before performing any operations.

9.4.2 Power head and/or motor assembly replacement

1. Remove the powerhead cover (2) from the powerhead plate (4), by pushing the clip (1).
2. Disconnect the cables (9) from the powerhead cover (2).
3. Using pliers, remove the circlips (3) and free the arm (6).
4. Using a screwdriver or a wrench, unscrew (7).
5. Remove motor hinge pin (11).
6. Remove the motor assembly (8).

If you only want to change the motor assembly (8), change it and reverse above procedure steps to rebuild.*

If you also want to remove the powerhead plate (4), follow the next steps:

1. Using a screwdriver or a wrench, unscrew (5).
2. Remove the brine valve nut (10).
3. Remove the powerhead plate (4).
4. Reverse above procedure steps to rebuild.**

* Torque to 70 in-lbs (7.9 Nm) motor assembly.

** Torque to 30 in-lbs (3.4 Nm) on backplate.

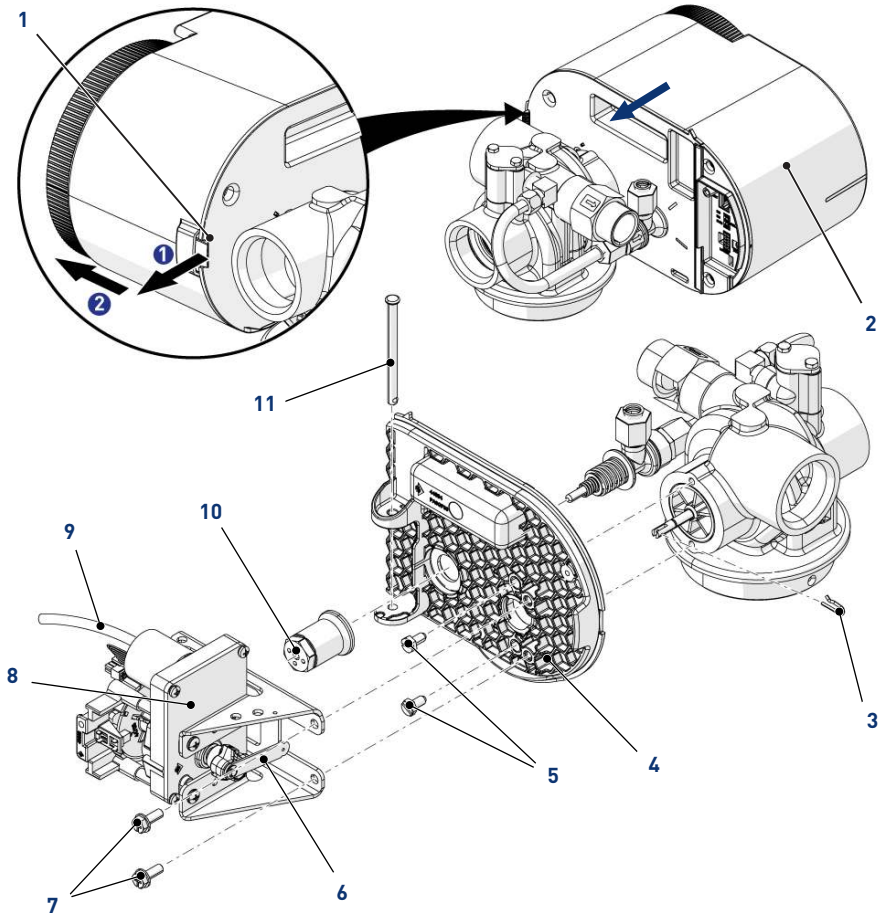

9.4.3 Controller replacement

1. Turn the controller **(3)** counter-clockwise.
2. Remove the controller **(3)** from the power head cover **(1)**.
3. Disconnect the old controller **(2)**.
4. Connect the new controller, see Electrical connections [→Page 52].
5. Reverse above procedure steps to rebuild.

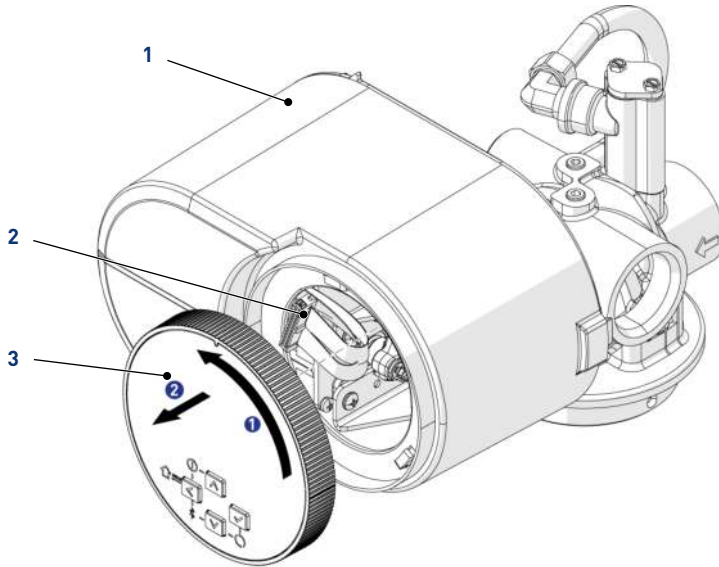

9.4.4 Piston and/or seal and spacer kit replacement

1. Remove the power head, see Power head and/or motor assembly replacement [→Page 143].
2. Using pliers, remove the piston (4).

Caution - material



Risk of damage on piston due to wrench use!

Using a wrench on piston rod coating will cause leakages.

3. Using a small hook, remove a seal (2).
4. Using the puller, remove a spacer (1).
5. Repeat the two previous steps for all the seals and spacers.
6. Lubricate each new seals (2).
7. Put back a seal (2) using the stuffer.
8. Put back a spacer (1) using the stuffer.
9. Repeat the two previous steps for all the seals and spacers.
10. Lubricate the piston o-ring (3).
11. Put back the piston (4).
12. Rebuild the power head, see Power head and/or motor assembly replacement [→Page 143].

Caution - material



Risk of damage due to wrong lubricant use

Do not use petroleum-based lubricants such as Vaseline, oils, or hydrocarbon-based lubricants.

Use only approved silicone grease or soapy water!

9.4.4.1 Special tools needed

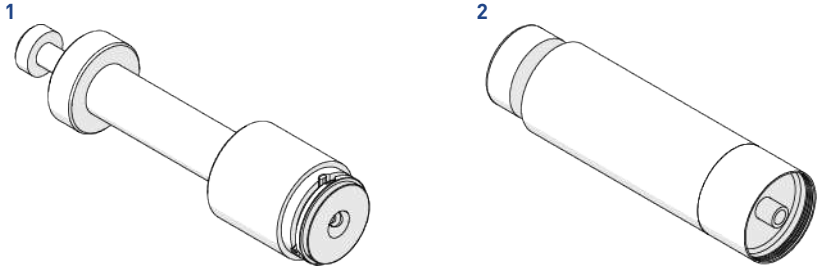

| Item | Part number NAM | Part number EMEA | Description |
|------|--------------------|---------------------|-------------------|
| 1 | | 17623 | Puller 2850/9500 |
| 2 | | 16516 | Stuffer 2850/9500 |

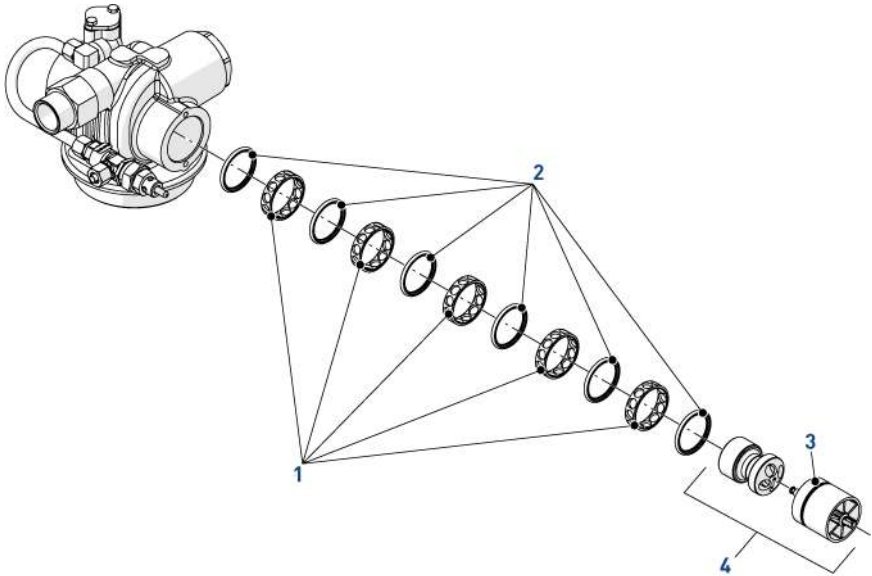

9.4.5 Injector cleaning

1. Using a 5/8" (16 mm) wrench, unscrew the nut (3) to release the tube (4).
2. Using a 5/16" (8 mm) wrench, unscrew (1) and remove the injector assembly (2).
3. Using flat screwdrivers, remove the injector nozzle (7) and the injector throat (8) from the injector body (10).
4. Clean the injector nozzle (7), the injector throat (8) and the filter (9) using compressed air, a soft brush or possibly a pin.
5. Lubricate the gaskets (6) and (11) using silicone grease.
6. Using a 5/16" (8 mm) wrench, assemble as shown the injector on the valve body (12).
7. Tight the nut (3) to fix the tube (4).

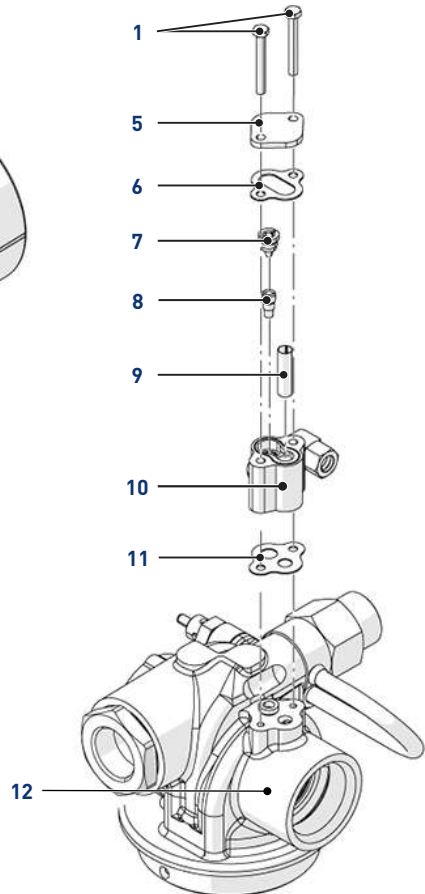
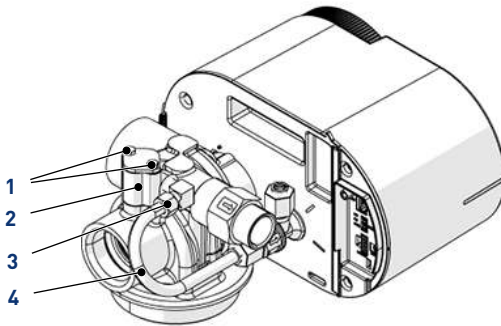

9.4.6 BLFC cleaning

1. Using a 5/8" (16 mm) wrench, unscrew the nuts (2) and remove the tube (1).
2. Using an 45/64" (18 mm) wrench, remove the BLFC holder (3).
3. Using pliers, remove the cage (4) from the BLFC holder (3).
4. Remove the BLFC washer (5) from the cage (4).
5. Change or clean the BLFC washer (5) with a terry cloth.
6. Clean the cage (4).
7. Lubricate the seal (6) with approved lubricant only.
8. Reverse above procedure steps to rebuild.

Mandatory



The washers (5) have to be installed with their chamfered side upfront the water stream flow.

Flow indication must be visible after the washer (5) is placed on the holder (3).

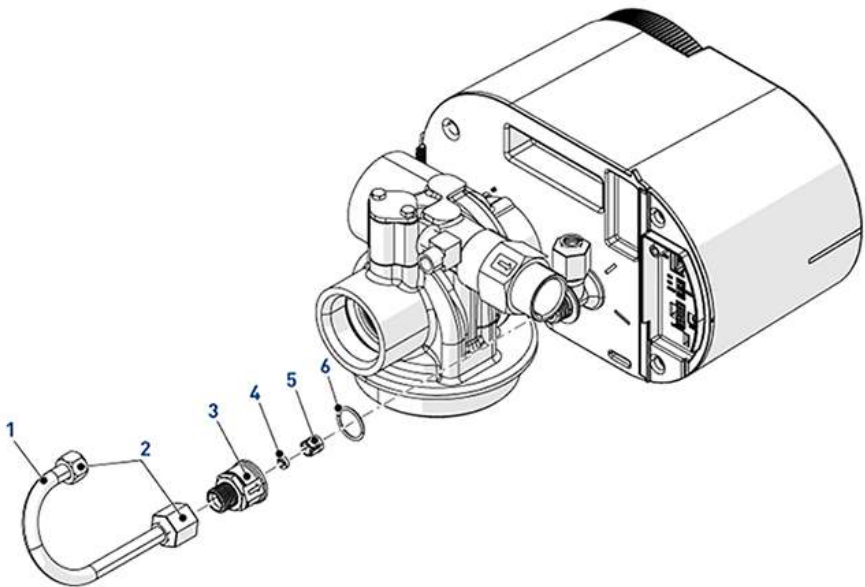

9.4.7 DLFC cleaning

1. Using a ½" (38 mm) wrench, remove the DLFC holder (2).
2. Using a flat screwdriver, remove the DLFC washer (1) from DLFC holder (2).
3. Clean or change the DLFC washer (1).
4. Reverse above procedure steps to rebuild.

Mandatory



The washers (1) have to be installed with their chamfered side upfront the water stream flow.

Flow indication must be invisible after the washer (1) is placed on the holder (2).

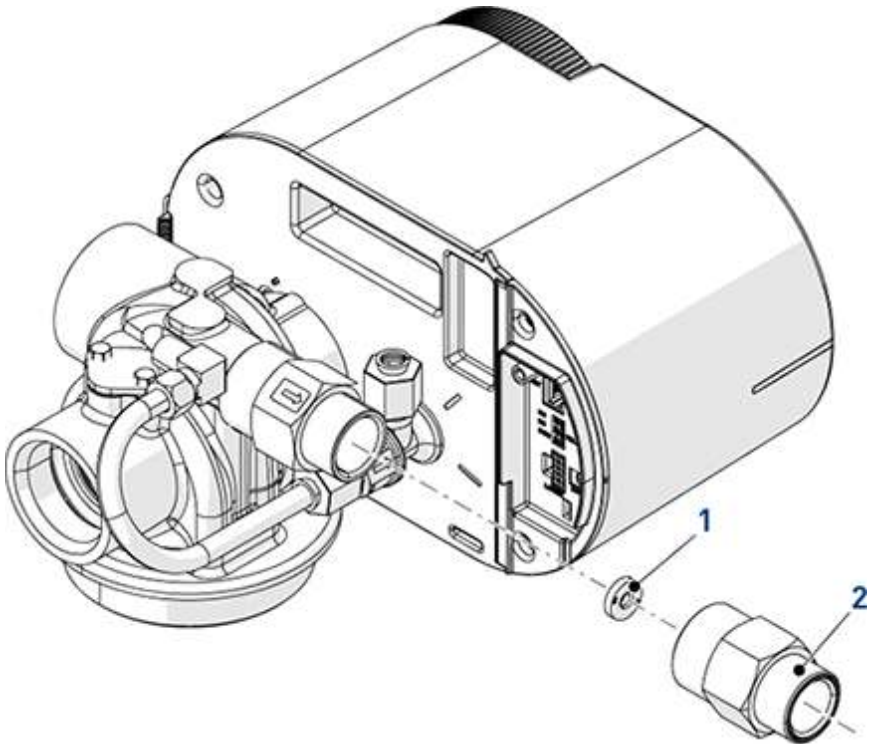

9.4.8 Optical sensor replacement

1. Remove the controller, see Controller replacement [→Page 145].
2. Disconnect the wire from the motor (4). to the optical sensor (3).
3. Release the optical sensor support (1) by pushing it back and up as shown.
4. Release the optical sensor (3) from its support (1) by pressing the clips (2).
5. Change the optical sensor (3).
6. Reverse above procedure steps to rebuild.

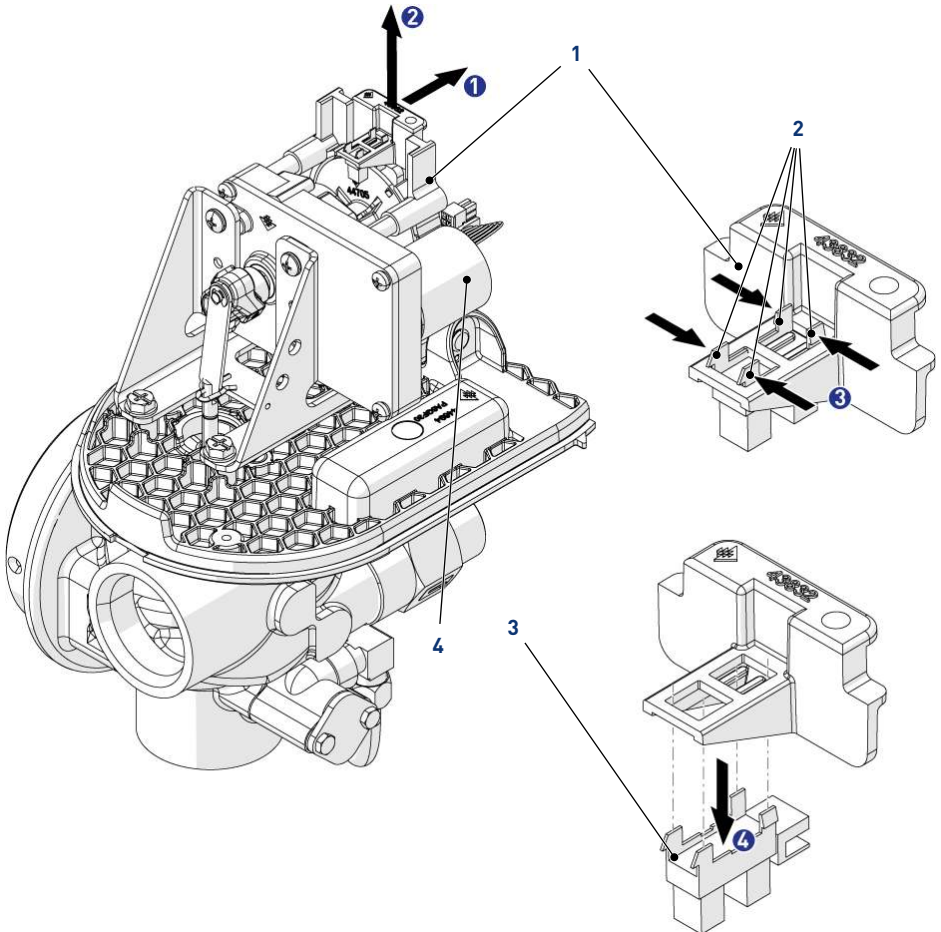

10 Troubleshooting

10.1 Error detection

Info



It can take up to 30 seconds before an error can be detected and displayed.

Mandatory



All the errors must be displayed on each controller before they can be corrected!

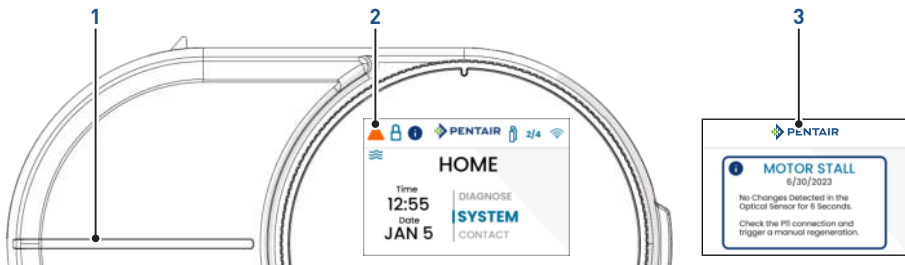

- If an error is detected, the status LED light (1) will be red and an error popup message (3) will be displayed;
- during an error condition, an orange triangle (2) is displayed on the left top corner, the unit continues to monitor flow and update the remaining capacity. Once an error condition is corrected, the unit returns to the operating status it was in prior to the error, and regeneration resumes according to normal programming;
- if an error is cleared by reprogramming the unit in the **Home** menu, the volume remaining may be reset to the full unit capacity (as though it had just regenerated);
- if an error is present, a regeneration can only occur manually. Refer to Trigger an immediate regeneration [→Page 132];
- if the unit was in regeneration when the error occurred, it completes the regeneration cycle and returns to service;
- when the problem is corrected, and the error no longer displays (it may take several seconds for the unit to stop displaying the error message), the unit returns to normal operation. The status LED light (1) is no longer Red, and turns Green if the unit is regenerating, or White if the unit is in service.

10.2 Controller

If reprogramming the unit clears the error, the remaining volume may be reset to full unit capacity (as if it had just regenerated).

- All the units in service remain in service;
- all the units in standby go to service;
- when the error appears, the unit in regeneration finishes the regeneration and goes to service;

- no regeneration starts while the error condition remains.

When the programming problem is corrected and the error is no longer displayed (it may take several seconds for all the units of the system to stop displaying the error), the system returns to normal operation.

Some examples of programming errors detected are:

- Power failure;
- system size: ex. programmed for 4 units, but there are only 2 units;
- units of measure do not correspond between the different valves of the system;

wrong type of valve programmed.

| Alarm name | Description | Resolution | Alarm color |
|------------------|---|--|----------------|
| MOTOR CONNECTOR | No motor movement detected | Check the motor connections and trigger manual regeneration | Red error |
| MOTOR TIMEOUT | No motor position feedback detected | Check the motor connections and trigger manual regeneration | Red error |
| MOTOR ENCODER | Undesired change detected | Trigger manual regeneration | Red error |
| MOTOR CURRENT | Motor overcurrent detected and exceeds thresholds | Trigger manual regeneration | Red error |
| MOTOR FAULT | Motor fault detected and exceeds thresholds | Trigger manual regeneration | Red error |
| COMM ERROR | Communication error between valves | Check connections between valves | Red error |
| CONTINUOUS FLOW | Continuous flow detected above set thresholds | Check major appliances for excess water flow | Yellow warning |
| EMERGENCY REGEN | Over 105% of capacity (volume and reserve) used | Emergency regeneration occurred. Repeated occurrences may indicate an undersized system. | Yellow warning |
| NO REGENERATION | 100 days have expired without regeneration | Trigger manual regeneration | Yellow warning |
| SERVICE INTERVAL | Service interval timer has expired | Perform service and update the Service Interval Date | Yellow warning |

| Alarm name | Description | Resolution | Alarm color |
|------------------|---|--|----------------|
| NO SALT DETECTED | No salt detected during the last regeneration | Add salt to the brine tank and trigger manual regeneration | Yellow warning |
| USB OVERCURRENT | Max allowable USB current is 500 mA | Check USB connection and reboot the device | Yellow warning |

10.3 System

| Problem | Cause | Solution |
|------------------------------------|---|--|
| Water softener fails to regenerate | Electrical service to unit has been interrupted. | Assure permanent electrical service (check fuse, plug, switch...). |
| | Timer is defective. | Replace controller. |
| | Power failure. | Reset time of day. |
| Hard water | By-pass valve is open. | Close by-pass valve. |
| | No salt is in brine tank. | Add salt to brine tank and maintain salt level above water level. |
| | Injector screen plugged. | Clean injector screen. |
| | Insufficient water flowing into brine tank. | Check brine tank fill time and clean brine line flow control if plugged. |
| | Leak at the distributor tube. | Make sure distributor tube is not cracked. Check o-ring and tube pilot. |
| | Internal valve leak. | Replace seals and spacers and/or piston. |
| Excessive salt consumption | Improper salt setting. | Check salt usage and salt setting. |
| | Excessive water in brine tank. | See problem "Excessive water in brine tank" below. |
| Controller cycles continuously | Misadjusted or broken optical sensor | Determine if optical sensor is faulty and replace it, or replace complete power head. |
| Loss of water pressure | Iron buildup in line to water softener. | Clean line to water softener. |
| | Iron buildup in water softener. | Clean the system and add mineral cleaner to mineral bed. Increase frequency of regeneration. |
| | Inlet of softener plugged due to foreign material broken loose from pipes by recent work done on plumbing system. | Remove piston and clean the valve. |

| Problem | Cause | Solution |
|------------------------------------|--|--|
| Loss of mineral through drain line | Air in water system. | Assure that well system has proper air eliminator control. Check for dry well condition. |
| | Improperly sized drain line flow control. | Check for proper drain rate. |
| Iron in conditioned water | Fouled mineral bed. | Check backwash, brine draw and brine tank refill. Increase frequency of regeneration. Increase backwash time. |
| Excessive water in brine tank | Plugged drain line flow control. | Clean flow control. |
| | Plugged injector system. | Clean injector and screen. |
| | Controller is not cycling. | Replace controller. |
| | Foreign material in brine valve. | Replace brine valve seat and clean valve. |
| | Foreign material in brine line flow control. | Clean brine line flow control. |
| Softener fails to draw brine | Drain line flow is plugged. | Clean drain line flow control. |
| | Injector is plugged. | Clean injector. |
| | Injector screen is plugged. | Clean screen. |
| | Line pressure is too low. | Increase line pressure to 20 PSI (1.4 bar). |
| | Internal valve leaks. | Change seals, spacers and piston assembly. |
| | Cam did not cycle. | Check drive motor and switches. |
| Drain flows continuously | Controller is not programming correctly. | Check controller program and positioning of controls. Replace power head assembly if not positioning properly. |
| | Foreign material in valve body. | Remove power head assembly and inspect bore. Remove foreign material and check valve body in various regeneration positions. |
| | Internal valve leak. | Replace seals and piston assembly. |

11 Spare parts and options

11.1 Valve parts list

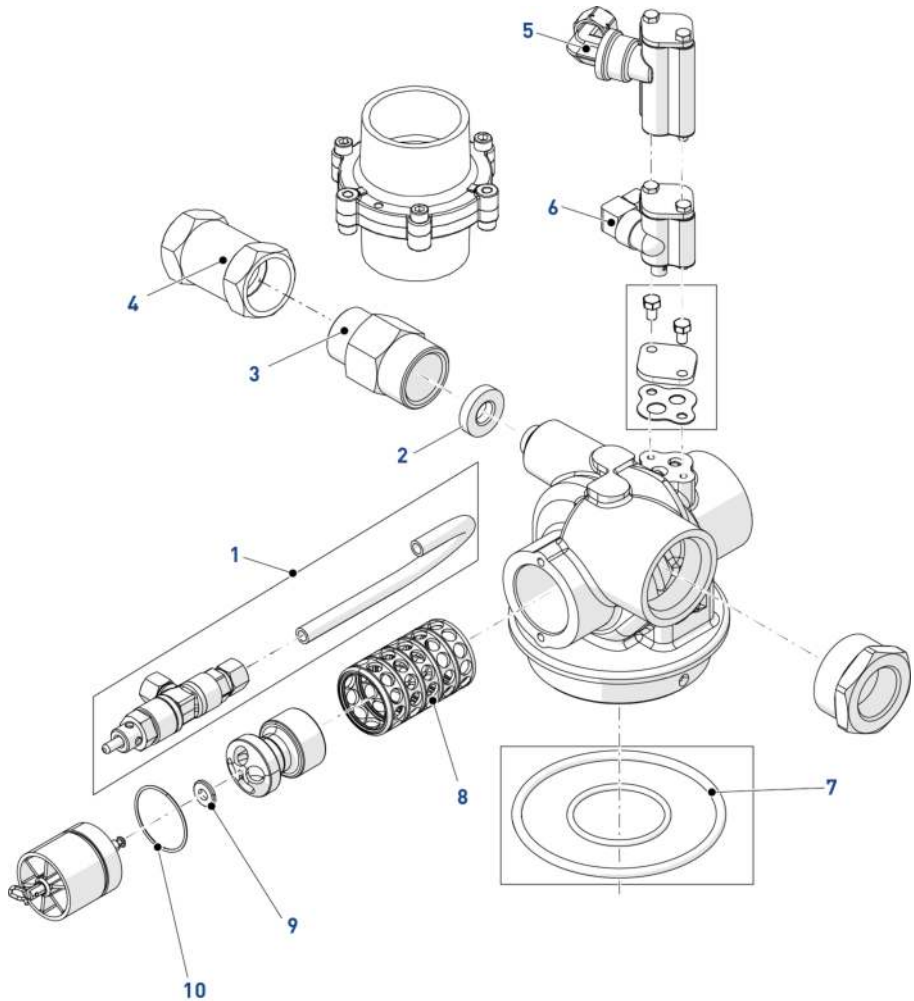

| item | Part number NAM | Part number EMEA | Description |
|------|--------------------|---------------------|--|
| 1 | | | Brine valve, [see Brine valve parts list (->Page 165)] |
| 2 | 12085 | 12085SP | Flow washer, 1.2 gpm |
| - | 12086 | / | Flow washer, 1.5 gpm |
| - | 12087 | / | Flow washer, 2 gpm |
| - | 12088 | 12088SP | Flow washer, 2.4 gpm |

| item | Part number NAM | Part number EMEA | Description |
|------|--------------------|---------------------|--|
| - | 12089 | / | Flow washer, 3.0 gpm |
| - | 12090 | 12090SP | Flow washer, 3.5 gpm |
| - | 12091 | 12091SP | Flow washer, 4 gpm |
| - | 12092 | / | Flow washer, 5 gpm |
| - | 12408 | 12408SP | Flow washer, 7 gpm |
| - | 16528 | 16528SP | Flow washer, 20 gpm |
| - | 16529 | 16529SP | Flow washer, 10 gpm |
| - | / | 16735SP | Flow washer, 12 gpm |
| - | 16736 | 16736SP | Flow washer, 15 gpm |
| - | 16737 | 16737SP | Flow washer, 25 gpm |
| - | 17814 | 17814SP | Flow washer, 6 gpm |
| - | / | 17943SP | Flow washer, 8 gpm |
| - | 17944 | 17944SP | Flow washer, 9 gpm |
| - | 19147 | / | Flow washer, 4.5 gpm |
| - | 19149 | / | Flow washer, 1.7 gpm |
| - | 19151 | 19151SP | Flow washer, 1.0 gpm |
| 3 | / | 25171-3 | DLFC, 1" NPT, 3/4" BSP assy, 3 gpm 2850/2910/9500 |
| - | / | 25171-4 | DLFC, 1" NPT, 3/4" BSP assy, 4 gpm 2850/2910/9500 |
| - | / | 25171-5 | DLFC, 1" NPT, 3/4" BSP assy, 5 gpm 2850/2910/9500 |
| - | / | 25171-7 | DLFC, 1" NPT, 3/4" BSP assy, 7 gpm 2850/2910/9500 |
| - | 60366-XX | 25581-ALL | DLFC Kit 1", 2850/9500, 10 to 25 gpm |
| - | 60711-XX | / | DLFC, 2" NPT, Less buttons, W/2 HLS |
| - | 60708-XX | / | DLFC, 1" F X 3/4" F, NPT, Brass |
| - | 60721-XX | / | DLFC, 1" F X 1" F, NPTF, No Button |
| - | 60701-XX | / | DLFC, 1" F X 1" F, NPT, Brass |
| - | 60702-XX | / | DLFC, 1" M X 1" F, NPT, Brass |
| 4 | 13640 | 13640 | Dole, Flow control, 30 gpm, 1" F X 1" FNPT |
| 5 | / | / | 1700/1710 injector assy (see 1700/1710 injector parts list [->Page 163]) |
| 6 | / | / | 1600/1650 injector assy (see 1600/1650 injector parts list [->Page 161]) |
| 7 | / | 29180 | Kit O-rings, Tank adapter 9500/2850 |
| - | 62197 | / | Kit O-rings, 2850 |
| 8 | 60129-20 | BU28684 | Seal & Spacer kit, 2850, Plastic |
| - | / | 29074 | Seal & Spacer kit, 2850, HW |
| - | 60129 | / | Seal & Spacer kit, 2850, HW & CW |
| 9 | / | 10209-01SP | Quad ring, 560, CD |

| item | Part number NAM | Part number EMEA | Description |
|------|--------------------|---------------------|--------------------------------|
| 10 | / | 25155 | Piston assy, 2850, WBP & HW |
| - | 60105-001 | / | Piston assy, 2850, EPDM |
| - | 60105-01 | / | Piston assy, 2850, HW |
| - | 60114-00 | 26494-01 | Piston assy, 2850, Filter, NBP |
| - | 60114-01 | 26494-00 | Piston assy, 2850, NHWBP |
| - | 60114-02 | 26494-02 | Piston assy, 2850, 1600, NBP |
| - | 60114-03 | / | Piston assy, 2850, 1700, NBP |

/not available

11.2 Power head parts list

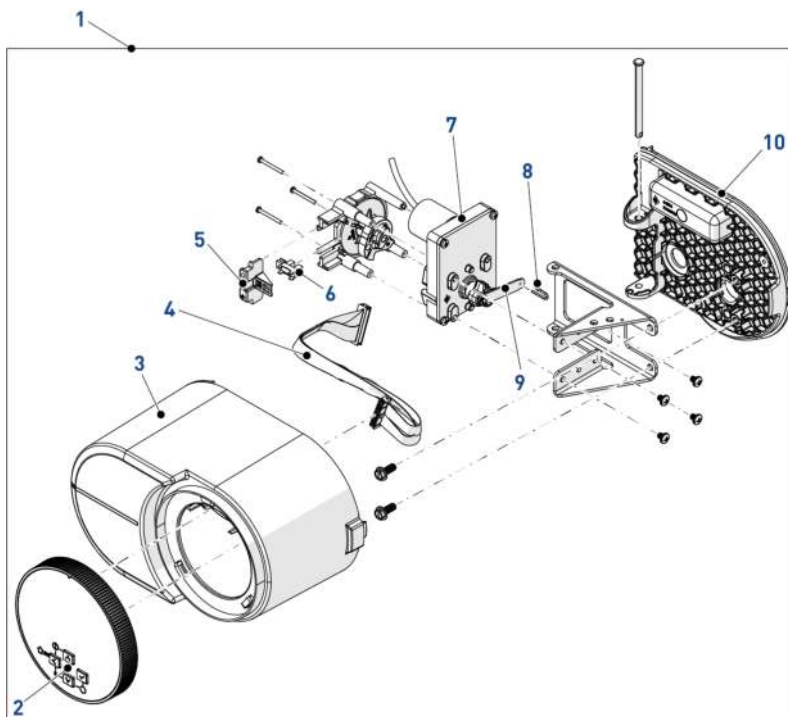

| Item | Part Number NAM | Part number EMEA | Description |
|------|--------------------|---------------------|---|
| 1 | 62218 | PH2850AIQ-001 | AiQ powerhead, 24 VDC, 50/60 HZ |
| 2 | 62217 | 29319 | AiQ controller |
| 3 | 62215 | 29320 | AiQ cover assy |
| 4 | 44715 | 44715SP | Main harness |
| 5 | 43832 | 43832SP | Bracket, Optical sensor |
| 6 | 1235373 | 1235373 | Module, Photo interrupter sensor |
| 7 | 62216 | 29317 | AiQ drive assembly, 24 V |
| 8 | 10909 | 10909SP | Cotter pin |
| 9 | 44703 | / | Drive assembly link |
| 10 | 62211 | 29318 | AiQ backplate assy |
| * | 44801 | 44801 | AiQ power supply EU, Sealed, 230 VAC - 24 VDC, 50/60 Hz |
| * | 44800 | / | AiQ power supply US, 24 VDC |
| * | 44800-01 | / | AiQ power supply AUST, 24 VDC |
| * | 44731-01 | / | Meter cable assy, Turbine, 13" (0.3 m) |

| Item | Part Number NAM | Part number EMEA | Description |
|------|--------------------|---------------------|---|
| * | 19121-11 | / | Meter cable assy, Paddle wheel, 17" (0.4 m) |
| * | 44731-02 | 44731-02SP | Meter cable assy, Turbine, 30" (0.7 m) |
| * | 44731-03 | / | Meter cable assy, Turbine, 300" (7.6 m) |
| * | 62210 | / | AiQ rain cover |

*not shown

/not available

11.3 1600,1700 Injector parts list

11.3.1 1600/1650 injector parts list

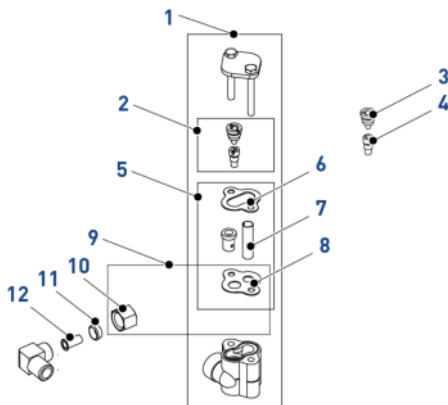

| Item | Part number NAM | Part number EMEA | Description |
|------|--------------------|---------------------|--|
| 1 | 60480-01 | / | Injector assy,1600, #1, Plastic |
| - | 60480-02 | / | Injector assy,1600, #2, Plastic |
| - | 60480-03 | / | Injector assy,1600, #3, Plastic |
| - | 60480-041 | / | Injector assy,1600, #4, Plastic |
| - | 60480-042 | / | Injector assy,1600, #2, Plastic |
| - | 60481-22 | / | Injector assy,1600, #2, Stainless steel |
| - | 60481-23 | / | Injector assy,1600, #3, Stainless steel |
| - | / | 29181 | Injector assy, 1650, #3 (#2, #1) 9500/2510/2750/2850/2910 |
| - | / | 29248 | Injector assy, 1600, HW, #2 (#0, #1, #3), 9500 |
| 2 | / | 29143 | Injector nozzle & throat, #1, White |
| - | / | 29144 | Injector nozzle & throat, #2, Blue |
| - | / | 29145 | Injector nozzle & throat, #3, Yellow |
| 3 | 10913-1 | / | Nozzle, Injector, #1, White |
| - | 10913-2 | / | Nozzle, Injector, #2, Blue |
| - | 10913-3 | / | Nozzle, Injector, #3, Yellow |
| - | 10913-4 | / | Nozzle, Injector, #4, Green |
| - | 10913BLK | / | Nozzle, Injector, Black |
| - | 12973-2 | / | Nozzle, Injector, #2, PVC |
| - | 12973-3 | / | Nozzle, Injector, #3, PVC |
| - | 10225-1 | / | Nozzle, Injector, #1, Stainless steel |

| Item | Part number NAM | Part number EMEA | Description |
|------|--------------------|---------------------|--|
| - | 10225-2 | / | Nozzle, Injector, #2, Stainless steel |
| - | 10225-3 | / | Nozzle, Injector, #3, Stainless steel |
| 4 | 10914-1 | / | Throat, Injector, #1, White |
| - | 10914-2 | / | Throat, Injector, #2, Blue |
| - | 10914-3 | / | Throat, Injector, #3, Yellow |
| - | 10914-4 | / | Throat, Injector, #4, Green |
| - | 12974-2 | / | Throat, Injector, #2, PVC |
| - | 12974-3 | / | Throat, Injector, #3, PVC |
| - | 12974-4 | / | Throat, Injector, #4, PVC |
| - | 10226-1 | / | Throat, Injector, #1, Stainless steel |
| - | 10226-2 | / | Throat, Injector, #2, Stainless steel |
| - | 10226-3 | / | Throat, Injector, #3, Stainless steel |
| 5 | / | 29183 | Injector service kit, 1650, 9500/2510/2750/2850/2910, DF |
| 6 | 10229 | / | Gasket, Injector cap, 1600 |
| 7 | 10227 | 10227SP | Injector screen |
| 8 | / | 23304SP | Injector body gasket |
| 9 | 60900-38 | / | Small parts kit, 1600, Brine |
| 10 | / | 10329SP | Fitting nut, 3/8" |
| 11 | / | 10330SP | Delrin sleeve, 3/8" |
| 12 | / | 10332SP | Insert sleeve, 3/8", Tube |

/not available

11.3.2 1700/1710 injector parts list

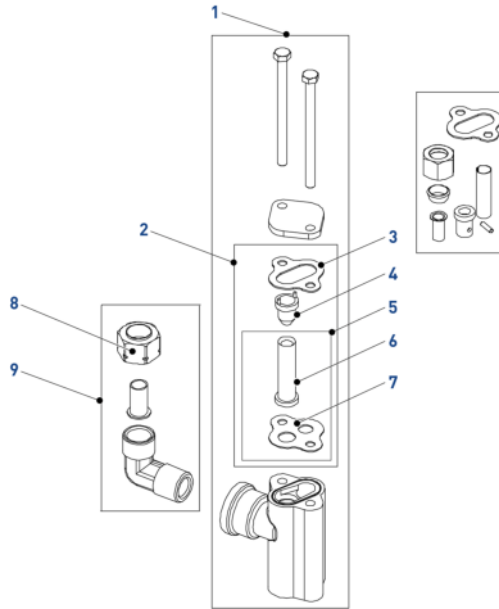

| Item | Part number NAM | Part number EMEA | Description |
|------|--------------------|---------------------|---|
| 1 | / | 29251 | Injector assy, 1700/1710, #6C (#7C), 2850/2910 |
| - | 60381-03 | / | Injector assy, 1700, #3C |
| - | 60381-04 | / | Injector assy, 1700, #4C |
| - | 60381-05 | / | Injector assy, 1700, #5C |
| 2 | / | 29184 | Injector service kit, 1710, 9500/2750/2850/2910, DF |
| 3 | 10229 | / | Gasket, Injector cap, 1600 |
| 4 | / | 14801-03C | Injector nozzle, 1700/1710, #3C, Yellow |
| - | / | 14801-05C | Injector nozzle, 1700/1710, #5C, White |
| - | / | 14801-06C | Injector nozzle, 1700/1710, #6C, Red |
| - | / | 14802-03C | Injector throat, 1700/1710, #3C, Yellow |
| - | / | 14802-05C | Injector throat, 1700/1710, #5C, White |
| - | / | 14802-06C | Injector throat, 1700/1710, #6C, Red |
| * | 60157-04 | / | Kit, Conversion, DF |
| 5 | 60900-39 | / | Small parts kit, 1700 Brine |
| 6 | / | 15415SP | Insert tube, 1/2" |
| 7 | / | 23304SP | Injector body gasket |
| 8 | / | 15414SP | Nut & sleeve assy, 1/2" |

| Item | Part number NAM | Part number EMEA | Description |
|------|--------------------|---------------------|---|
| 9 | / | 29221 | Kit elbow fitting male, 1.2 T x 3/8 NPT |

/not available

11.4 Brine valve parts list

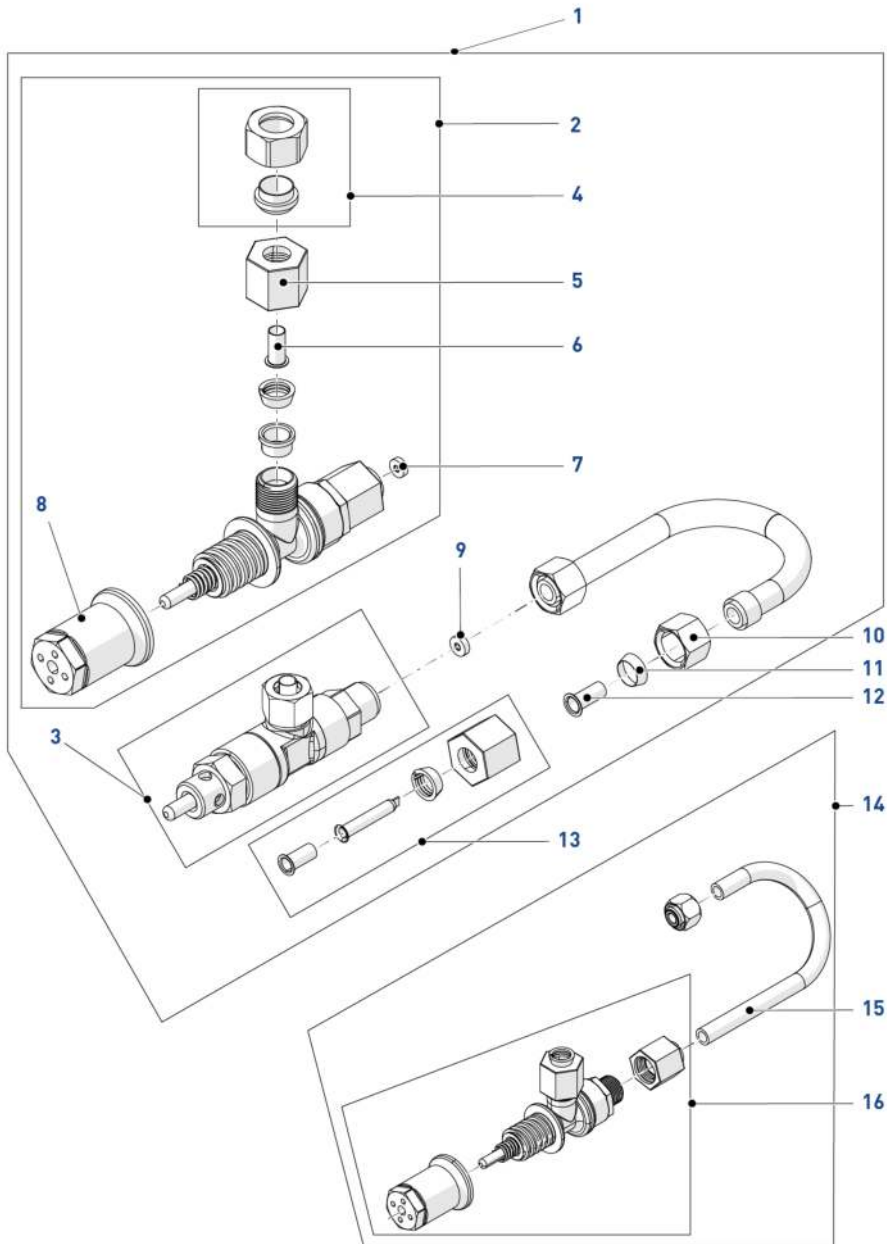

Illustration 1:

| Item | Part number NAM | Part number EMEA | Description |
|------|--------------------|---------------------|--|
| 1 | 60011 | / | BV, 1650, Short stem less |
| - | 60011-020 | / | BV, 1650, Short stem, 0.5 gpm |
| - | 60011-030 | BU28797-1 | BV, 1650, 2850/2910, 1 gpm |
| - | 60011-090 | / | BV, 1650, Short stem |
| - | 60029 | / | BV, 1650, Short stem less |
| - | 60029-020 | / | BV, 1600, Short stem, 0.5 gpm |
| - | 60029-021 | / | BV, 1600, Short stem |
| - | 60029-030 | 26909-1 | BV, 1600, Short stem, 1 gpm |
| - | 60029HW | / | BV, 1600, Short stem |
| 2 | / | 18092-1 | Kit BV 1600 & BLFC assy, Industrial, 1 gpm |
| 3 | / | 26677-1 | Kit BV 1650 assy, 1 gpm |
| 4 | / | 15414SP | Nut & sleeve assy 1/2" |
| 5 | / | 19625SP | BV 1650, Plastic nut assy |
| - | / | 14202-01SP | Screw adapter clip, 9000/9100 |
| 6 | / | 15415SP | Insert tube 1/2" |
| 7 | / | 12085SP | Flow washer, 1.2 gpm |
| - | / | 12087SP | Flow washer, 2 gpm |
| - | / | 12091SP | Flow washer, 4 gpm |
| - | / | 12408SP | Flow washer, 7 gpm |
| 8 | / | 17906SP | Stem guide BV |
| 9 | 12095 | 12095SP | Flow washer BLFC, 0.5 gpm |
| 10 | / | 10329SP | Fitting nut, 3/8" |
| 11 | / | 10330SP | Delrin sleeve, 3/8" |
| 12 | / | 10332SP | Insert sleeve, 3/8", Tube |
| 13 | 60900-38 | / | Small parts kit, 1600 brine |
| 14 | / | 26991-2 | BV, 1700 assy, 2750 NBP, 2850 WBP, 2910, 2 gpm |
| - | 60034-00 | / | BV, 1700, Blank |
| - | 60034-10 | / | BV, 1700, 1 gpm |
| - | 60034-12 | / | BV, 1700, 1.2 gpm |
| - | 60034-15 | / | BV, 1700, 1.5 gpm |
| - | 60034-20 | / | BV, 1700, 2 gpm |
| - | 60034-21 | / | BV, 1700, EPDM, 2 gpm |
| - | 60034-30 | / | BV, 1700, 3 gpm |
| - | 60034-40 | / | BV, 1700, 4 gpm |
| - | 60034-50 | / | BV, 1700, 5 gpm |

| Item | Part number NAM | Part number EMEA | Description |
|------|--------------------|---------------------|---|
| 15 | 16460 | 19338 | Brine tube, 1700, 2850, NBP, Copper |
| 16 | / | BU28610-2 | BV, 1710, 2750 NPB, 2850 WBP, 2910, 2 gpm |
| - | / | BU28610-4 | BV, 1710, 2750 NPB, 2850 WBP, 2910, 4 gpm |
| - | / | BU28608-2 | BV, 1710, 2850 NBP, 2 gpm |
| - | / | 24181-1.2 | Kit BV 1700 assy, 1.2 gpm |
| - | / | 24181-2 | Kit BV 1700 assy, 2 gpm |
| - | / | 24181-4 | Kit BV 1700 assy, 4 gpm |

/not available

11.5 Safety brine valves list

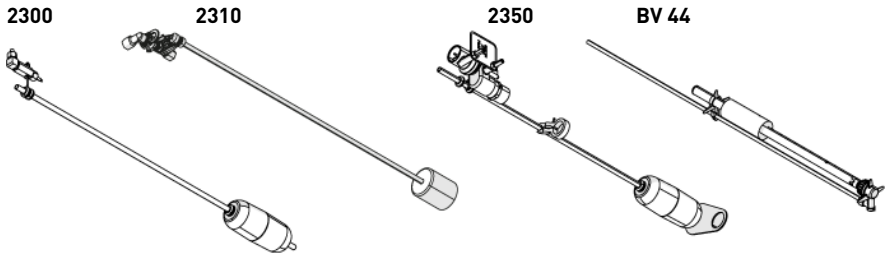

| Item | Brine system | Part number NAM | Part number EMEA | Description |
|------|--------------|--------------------|---------------------|--|
| - | 1600 | / | 27833 | Safety brine valve 2300, Without air check |
| - | | / | 27834 | Safety brine valve 2300, HW, Without air check |
| - | | 60067-03 | 60067-03 | Safety brine valve 2310, Without air check |
| - | | / | 25687 | Brine valve 44, 35.98" [914 mm] |
| - | | / | 18961 | Brine valve 44, 49.21" [1250 mm] |
| - | | 1710 | 60038 | 25453 |
| - | / | | 25364 | Mounting part, 1" NPT male x 3/8" female |
| - | 60027-FFA | | / | Safety brine valve body, 2300 |
| - | 60068-30 | | / | Float assy, 2310, W/30", Rod |

/not available

11.6 Safety brine valves parts list

11.6.1 Safety brine valves 2300 parts list

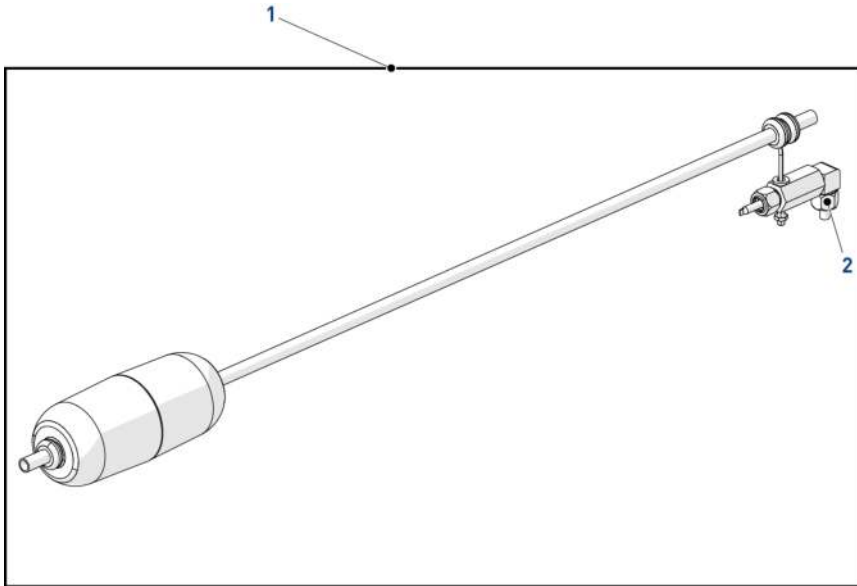

| Item | Part number NAM | Part number EMEA | Description |
|------|--------------------|---------------------|------------------------------------|
| 1 | / | 27833 | SBV, 2300, 3/8", Without air check |
| * | 60900-38 | 10329SP | Fitting nut 3/8" |
| * | 60900-38 | 10330SP | Delrin sleeve 3/8" |
| * | 60900-38 | 10332SP | Insert sleeve 3/8", Tube |

*not shown

/not available

11.6.2 Safety brine valves 2310 parts list

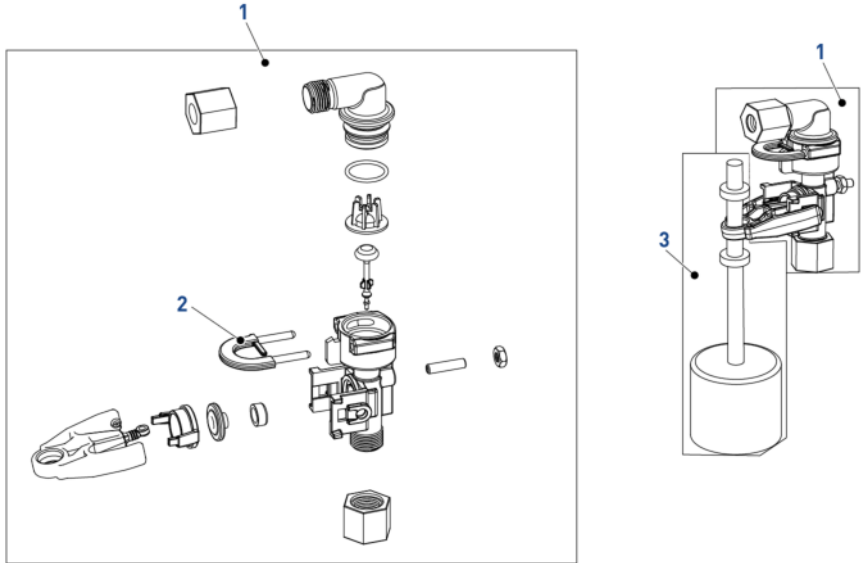

| Item | Part number NAM | Part number EMEA | Description |
|------|--------------------|---------------------|-------------------------|
| 1 | / | 60014SP | Body assy, SBV, 2310 |
| 2 | / | 18312SP | Retainer, Drain |
| 3 | / | 60068-30SP | Float assy, 2310 |
| - | 11183 | / | O-Ring, -017 |
| - | 19625 | / | Nut assy, 3/8", Plastic |

/not available

11.7 Distribution systems parts list

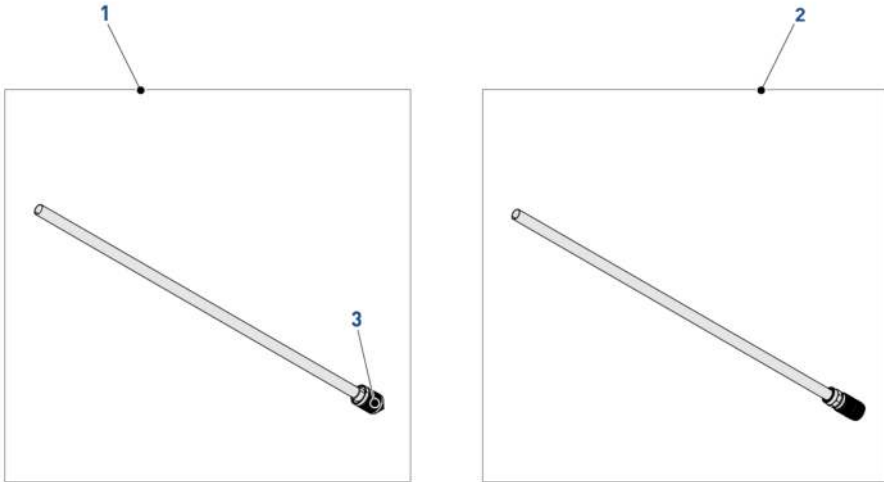

| Item | Part number NAM | Part number EMEA | Description |
|------|--------------------|---------------------|--|
| 1 | / | 18404 | Distributor assy, 2", 71.65" (1m82) |
| 2 | / | BU26052 | Distributor assy HW, 2", 71.65" (1m82) |
| - | 13851 | / | Distributor assy, 1", Lower, Gray |
| - | 13851-02 | / | Distributor assy, 1", Lower, Red |
| - | 13851-10 | / | Distributor assy HW, 1", Lower |
| 3 | / | 18396 | Bottom distributor, 2" |

/not available

11.8 Air checks list

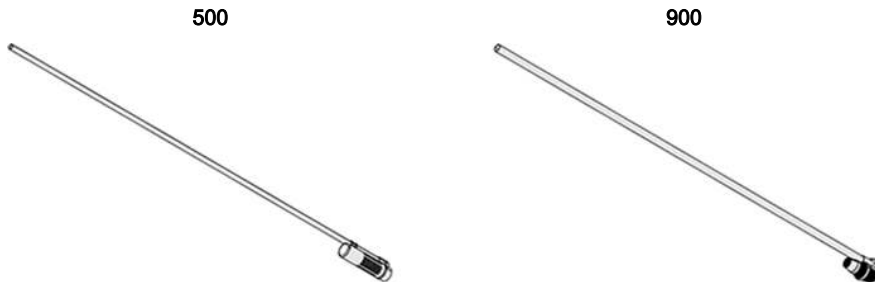

| Item | Brine system | Part number NAM | Part number EMEA | Description |
|------|--------------|-----------------|------------------|----------------------------------|
| - | 1600 | / | 18168 | Air check, 500A, 36" [915 mm] |
| - | | / | 26773 | Air check, 500A, 49.21" [1m25] |
| - | | / | 23473 | Air check, 500, HW, 36" [915 mm] |
| - | | 60002-34 | / | Air check, #500, 34" [864 mm] |
| - | | 60002-36 | / | Air check, #500, 36" [915 mm] |
| - | | 60002-48 | / | Air check, #500, 48" [1m20] |
| - | 1710 | / | 18979 | Air check, 900, 74" [1m88] |
| - | | / | BU28510 | Air check, 900, 43.3" [1m10] |
| - | | / | 18980 | Air check, 900, HW |
| - | | 60009-00 | / | Air check, #900, Commercial |

/not available

11.9 Meters parts list

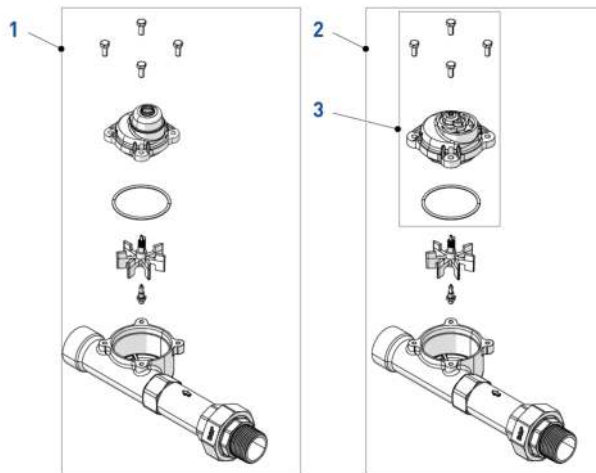

| Item | Part number NAM | Part number EMEA | Description |
|------|-----------------|------------------|--|
| 1 | / | 29096 | Kit meter assy, 1", Stainless steel, NXT2 |
| 2 | / | 29097 | Kit meter assy, 1.5, Stainless steel, NXT2 |
| 3 | 61936 | 61936 | Meter cover, for SS mechanical or electronic, 1" to 3" |
| * | 62049-01 | / | Kit, 1" and 1 1/2" meter, STD |
| * | 61933-10 | / | Meter assy, 1" to 1/2" NPT, STD, SS |
| * | 14038 | / | Meter cap assy, STD, Plastic |

| Item | Part number NAM | Part number EMEA | Description |
|------|-----------------|------------------|-------------------------------------|
| * | 13882 | / | Post, Meter impeller |
| * | 13509 | / | Impeller, Meter |
| * | 13847 | / | O-ring, -137, EPDM, STD, Meter |
| * | 12112 | / | Screw, Hex HD Mach, 10 to 24 x 1/2" |
| * | 17542 | / | Flow straightener, 1 1/2" |

*not shown

/not available

11.10 Additional parts list

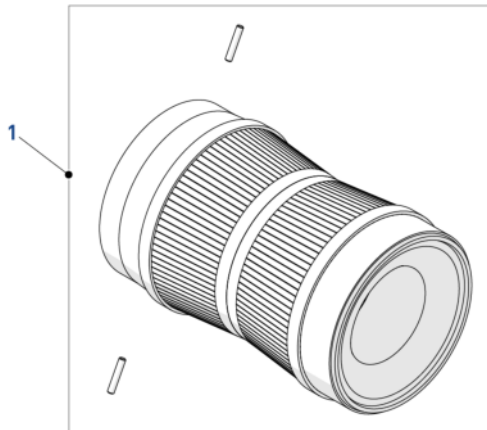

| Item | Part number NAM | Part number EMEA | Description |
|------|-----------------|------------------|--------------------------------------|
| 1 | / | Kit 8 | Top distributor 2" and pin, Assy |
| - | / | Kit 9 | Top distributor 2" and pin, Assy, HW |

/not available

11.11 Other components list

Mixing assembly

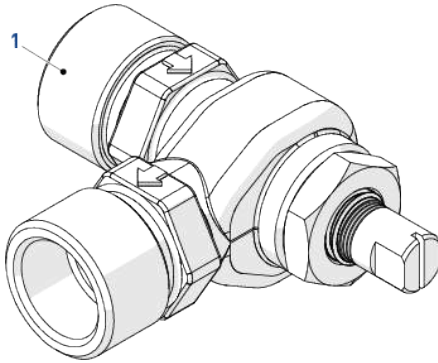

Rotating side mount adaptor

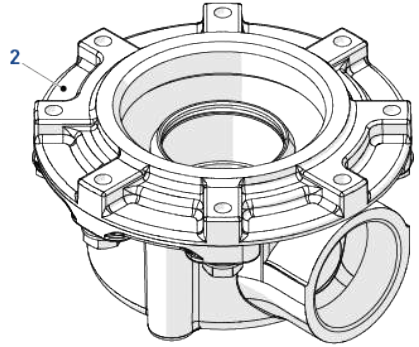

| Item | Part number NAM | Part number EMEA | Description |
|------|--------------------|---------------------|-----------------------------------|
| 1 | / | BU61564-10 | Mixing assy, 1", Industrial |
| 2 | 61414 | 61415-20 | Rotating adapter assy, Side mount |

/not available

12 Disposal

The device must be scrapped in accordance with directive 2012/19/EU or the environmental standards in force in the country of installation. The components included in the system must be separated and recycled in a waste recycling center that conforms with the legislation in force in the country of installation. This will help to reduce the impact on the environment, health, safety and help to promote recycling. Pentair does not collect used product for recycling. Contact your local recycling center for more information.



Notes

WWW.PENTAIR.EU
WWW.PENTAIR.COM