

Fleck 4600 SXT - MECH



IMPORTANT SAFETY INSTRUCTIONS

Read and follow all instructions

Save these instructions

Table of Contents

1	Generalities	6
1.1	Scope of the documentation	6
1.2	Release management	6
1.3	Manufacturer identifier, product identification	6
1.4	Intended use	6
1.5	Abbreviations used	6
1.6	Norms	7
1.6.1	Applicable norms	7
1.6.2	Available certificates	8
1.7	Procedure for technical support	8
1.8	Copyright and Trademarks	8
1.9	Limitation of liability	8
1.10	Illustrations	9
1.11	Pentair Scan application	10
2	Safety.....	11
2.1	Safety pictograms definition	11
2.2	Serial label location	12
2.3	Hazards	12
2.3.1	Personnel	12
2.3.2	Material	12
2.4	Hygiene and sanitization	13
2.4.1	Sanitary issues	13
2.4.2	Hygiene measures	13
3	Description	14
3.1	Technical specifications	14
3.2	Performance flow rate characteristics	15
3.3	Outline drawing	16
3.3.1	SXT controller	16
3.3.2	MECH controller.....	17
3.4	Components description and location	18
3.4.1	SXT controller	18
3.4.2	MECH controller.....	19
3.5	System regeneration cycle	21
3.5.1	Downflow regeneration cycle (5-cycles operation)	21
3.5.2	Filter cycle (3-cycles operation)	23
3.6	Special configurations	25
3.6.1	SXT controller - Configurations for softener and filter	25
3.6.2	MECH controller - Configurations for volumetric and time clock softeners.....	27

3.7	Options available on the valve	28
4	System sizing.....	29
4.1	Recommended Injector/DLFC/BLFC-Valve configuration.....	29
4.2	Sizing a softener (single unit)	29
4.2.1	Parameters to be considered	29
4.2.2	Determining the required volume of resin	30
4.2.3	Resin exchange capacity and capacity of the unit	31
4.2.4	Valve configuration.....	32
4.3	Cycle time calculation.....	33
4.3.1	SXT controller	33
4.3.2	MECH controller.....	35
4.4	Salt amount definition.....	35
4.5	Injector flow rates	36
4.5.1	1600 injectors.....	36
4.5.2	1650 injectors	37
5	Installation	39
5.1	Warnings	39
5.2	Safety notices for installation	39
5.3	Installation environment.....	39
5.3.1	General.....	39
5.3.2	Water.....	40
5.3.3	Electrical	40
5.3.4	Mechanical	41
5.4	Integration constraints	41
5.5	Valve on tank assembly	42
5.6	Valve connection to piping	42
5.6.1	Top-mounted valve installation	43
5.7	Block diagram and configuration example	45
5.8	Regeneration flows	46
5.8.1	SXT controller	46
5.8.2	MECH controller.....	46
5.9	Electrical connections	47
5.9.1	SXT controller	47
5.9.2	MECH controller.....	48
5.10	Bypassing.....	49
5.11	Drain line connection.....	49
5.12	Overflow line connection.....	51
5.13	Brine line connection.....	52
6	Programming	53
6.1	SXT controller	53

6.1.1	Display	53
6.1.2	Commands	55
6.1.3	Setting the time of the day (TD)	55
6.1.4	Basic programming	55
6.1.5	Master programming mode.....	56
6.1.6	Filter programming.....	64
6.1.7	Diagnostic.....	64
6.1.8	Resetting the controller	66
6.2	MECH controller	67
6.2.1	Time of day	67
6.2.2	Volumetric	68
6.2.3	Time clock	70
6.2.4	Salt volume per regeneration	72
7	Comissioning	74
7.1	Water filling, draining and waterproofness inspection.....	74
7.1.1	SXT controller	74
7.1.2	MECH controller.....	75
7.2	Sanitization.....	75
7.2.1	Disinfection of water softeners.....	75
7.2.2	Sodium or calcium hypochlorite.....	76
7.2.3	Electro chlorination (if present).....	76
8	Operation.....	77
8.1	SXT controller	77
8.1.1	Display	77
8.1.2	Recommendations	78
8.1.3	Manual regeneration.....	78
8.1.4	Operation during a power failure.....	79
8.2	MECH controller	80
8.2.1	Display during operation.....	80
8.2.2	Recommendations	81
8.2.3	Manual regeneration.....	81
8.2.4	Operation during power failure	81
9	Maintenance	82
9.1	General system inspection	82
9.1.1	Water quality	82
9.1.2	Mechanical Checks	82
9.1.3	Regeneration test.....	83
9.2	Recommended maintenance plan.....	83
9.2.1	Valve used for softening.....	83
9.2.2	Valve used for filtration.....	86
9.3	Recommendations	88
9.3.1	Use original spare parts	88
9.3.2	Use original approved lubricants.....	88
9.3.3	Maintenance instructions	88

9.4	Cleaning and maintenance	88
9.4.1	First steps	88
9.4.2	Controller motor replacement	89
9.4.3	Controller replacement	90
9.4.4	Power head disassembly/replacement	92
9.4.5	Piston and/or brine valve and/or seal and spacer kit replacement.....	93
9.4.6	Micro-swithes and/or drive cam replacement.....	95
9.4.7	Brine cam replacement	97
9.4.8	Injector cleaning.....	98
9.4.9	BLFC cleaning	99
10	Troubleshooting	100
10.1	Error detection	103
10.1.1	Motor stall/cam sense error.....	103
10.1.2	Motor run-ON error/cycle sense error.....	104
10.1.3	Regeneration failure	104
10.1.4	Memory error	105
11	Spare parts and options.....	106
11.1	Valve parts list.....	106
11.2	Power head parts list	108
11.2.1	SXT controller	108
11.2.2	MECH controller.....	109
11.3	Safety brine valves list	111
11.4	Safety brine valves 2310 parts list	112
11.5	Bypass valve assembly list	112
11.5.1	1" BSP female stainless steel bypass	112
11.5.2	1" BSP female brass bypass with mixing	113
11.5.3	Plastic bypass (no yoke).....	114
11.6	Distribution systems parts list	115
11.7	Air checks list.....	116
11.8	Meters parts list.....	116
11.8.1	SXT controller	116
11.8.2	MECH controller.....	117
11.9	Additional parts list.....	118
12	Disposal.....	119

1 Generalities

1.1 Scope of the documentation

The documentation provides the necessary information for appropriate use of the product. It informs the user to ensure efficient execution of the installation, operation or maintenance procedures.

The content of this document is based on the information available at the time of publication. The original version of the document was written in English.

For safety and environmental protection reasons, the safety instructions given in this documentation must be strictly followed.

This manual is a reference and will not include every system installation situation. The person installing this equipment should have:

- training in the Fleck series, SXT - MECH controllers and water softener installation;
- knowledge of water conditioning and how to determine proper controller settings;
- basic plumbing skills.

This document is available in other languages on <https://www.pentair.eu/product-finder/product-type/control-valves>.

1.2 Release management

Revision	Date	Authors	Description
A	20.03.2023	BRY	First edition.
B	25.11.2025	STF	Corrections.

1.3 Manufacturer identifier, product identification

Manufacturer: **EMEA legal entity**
 Pentair Manufacturing Italy S.R.L.
 Via Tiziano 32
 20145 Milano (MI)
 Italy

Product identification: Fleck 4600 SXT - MECH

1.4 Intended use

The device is intended for domestic applications use only and it is purpose-built for water treatment.

1.5 Abbreviations used

Assy Assembly

BLFC	Brine Line Flow Controller
BV	Brine Valve
CW	Cold Water
DF	Down Flow
Distr	Distribution
DLFC	Drain Line Flow Controller
HW	Hot Water
Inj	Injector
N/A	Not Available
NBP	No By Pass
PN	Part Number
QC	Quick connect
Regen	Regeneration
S&S	Seals & Spacers
SBV	Safety Brine Valve
STD	Standard
SM	Side Mounted
Sys	System
TC	Time Clock
TM	Top Mounted
UF	Up Flow
VB	Valve Body

1.6 Norms

1.6.1 Applicable norms

Comply with the following guidelines:

- 2006/42/EC: Machinery Directive;
- 2014/35/UE: Low Voltage Directive;
- 2014/30/UE: Electromagnetic compatibility;
- 2011/65/UE: Restriction of use of certain hazardous substances in electrical and electronic equipment (RoHS);
- UNI EN ISO9001.

Meets the following technical standards:

- EN 55014-1;
- EN 55014-2;
- EN 61000-6-1;
- EN 61000-6-2;

- EN 61000-6-3;
- EN 61000-6-4;
- EN 61010-1;
- EN 61000-3-2;
- EN 61000-3-3.

1.6.2 Available certificates

- CE;
 - DM174;
 - ACS.
- Please find beside the certifications for some of our product families. Please note that this list is not an exhaustive list of all our certifications. In case of need for more information please contact us.



1.7 Procedure for technical support

Procedure to follow for any technical support request:

1. Collect the required information for a technical assistance request.
 - ⇒ Product identification [see Serial label location [→Page 12] and Recommendations [→Page 88]];
 - ⇒ Description of the device problem.
2. Please refer to the Troubleshooting. If the problem persists contact your supplier.

1.8 Copyright and Trademarks

All indicated Pentair trademarks and logos are property of Pentair. Third party registered and unregistered trademarks and logos are the property of their respective owners.

© 2023 Pentair. All rights reserved.

1.9 Limitation of liability

Pentair Quality System EMEA products benefit, under specific conditions, from a manufacturer warranty that may be invoked by Pentair's direct customers. Users should contact the vendor of this product for applicable conditions and in case of a potential warranty claim.

Any warranty provided by Pentair regarding the product will become invalid in case of:

- installation done by a non-water-professional;
- improper installation, improper programming, improper use, improper operation and/or maintenance leading to any kind of product damages;
- improper or unauthorized intervention on the controller or components;
- incorrect, improper or wrong connection/assembly of systems or products with this product and vice versa;
- use of a non-compatible lubricant, grease or chemicals of any type and not listed by the manufacturer as compatible for the product;
- failure due to wrong configuration and/or sizing.

Pentair accepts no liability for equipment installed by the user upstream or downstream of Pentair products, as well as for process/production processes which are installed and connected around or even related to the installation. Disturbances, failures, direct or indirect damages that are caused by such equipment or processes are also excluded from the warranty. Pentair shall not accept any liability for any loss or damage to profits, revenues, use, production, or contracts, or for any indirect, special or consequential loss or damage whatsoever. Please refer to the Pentair List Price for more information about terms and conditions applicable to this product.

1.10 Illustrations

Depending on the configuration of your valve, it can be mounted with a SXT or MECH controller. The SXT controller is used to illustrate this document, however when necessary, all configurations are illustrated.

1.11 Pentair Scan application

Pentair Scan mobile application is the ideal support for the maintenance person in his daily business. A simple scan of the serial label present on the valve with a smartphone gives an instantaneously access to all updated information related to the product, such as:

- valve's and tanks detailed configuration;
- manuals;
- spare parts lists;
- troubleshooting recommendations;
- multi-lingual videos, detailing how to best service a part;
- informations about new products, latest technologies, novelties about the Blue Network program, etc.

1. Download the application Pentair **Scan** from  or  in a smartphone.

Mandatory



The app must be open to scan and identify Pentair products!

2. Open the Pentair **Scan** application.
3. Either scan the serial number and part number from the product label or enter them manually.
 - ⇒ For serial label location, refer to Serial label location [→Page 12].
4. Navigate to find information.

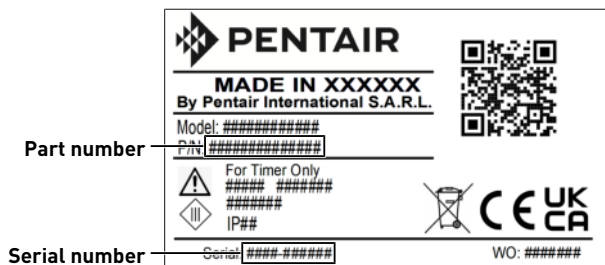

2 Safety

2.1 Safety pictograms definition

DANGER



This combination of symbol and keyword indicates an imminently hazardous situation that will result in serious or fatal injury if not avoided.

WARNING



This combination of symbol and keyword indicates a potentially hazardous situation that can result in serious or fatal injury if not avoided.

CAUTION



This combination of symbol and keyword indicates a potentially hazardous situation that can result in minimal or minor injury if not avoided.

Caution - material



This combination of symbol and keyword indicates a potentially hazardous situation that can result in material damage if not avoided.

Prohibition



Mandatory advice to follow.

Mandatory



Applicable guideline, measure.

Info



Informative comment.

2.2 Serial label location

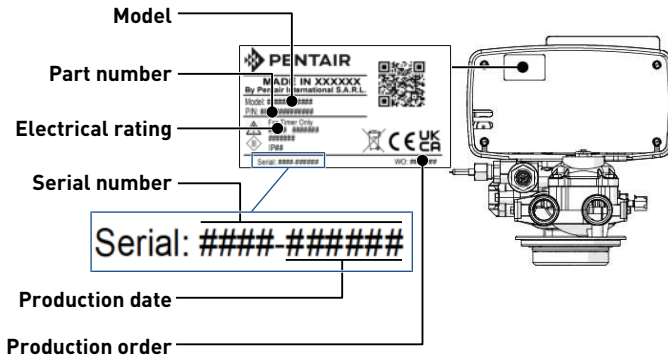

Mandatory



Ensure that the serial label and the safety labels on the device are completely legible and clean !

If necessary, replace them with new labels in the same positions.

2.3 Hazards

All the safety and protection instructions contained in this document must be observed in order to avoid temporary or permanent injury, damage to property or environmental pollution.

At the same time, any other legal regulations, accident prevention and environmental protection measures, as well as any recognized technical regulations relating to appropriate and risk-free methods of working which apply in the country and place of use of the device must be adhered to.

Any non-observation of the safety and protection rules, as well as any existing legal and technical regulations, will result in a risk of temporary or permanent injury, damage to property or environmental pollution.

2.3.1 Personnel

⚠ CAUTION



Risk of injury due to improper handling!

Only qualified and professional personnel, based on their training, experience and instruction as well as their knowledge of the regulations, safety rules and operations performed, are authorized to carry out necessary work.

2.3.2 Material

The following points must be observed to ensure proper operation of the system and the safety of user:

- be careful of high voltages present on the transformer (230 V, 50 Hz);

- do not put your fingers in the system (risk of injuries with moving parts and shock due to electric voltage).

2.4 Hygiene and sanitization

2.4.1 Sanitary issues

Preliminary checks and storage

- Check the integrity of the packaging. Check that there is no damage and no signs of contact with liquid to make sure that no external contamination occurred;
- the packaging has a protective function and must be removed just before installation. For transportation and storage, appropriate measures should be adopted to prevent the contamination of materials or the objects themselves.

Assembly

- Assemble only with components which are in accordance with drinking water standards;
- after installation and before use, perform one or more manual regenerations in order to clean the media bed. During such operations, do not use the water for human consumption. Perform a disinfection of the system in the case of installations for treatment of drinking water for human use.

Info



This operation must be repeated in the case of ordinary and extraordinary maintenance.

It should also be repeated whenever the system remains idle for a significant time.

Info



Valid only for Italy

In case of equipment used in accordance with the DM25, apply all the signs and obligations arising from the DM25.

2.4.2 Hygiene measures

Disinfection

- The materials used for the construction of our products meet the standards for use with potable water; the manufacturing processes are also geared to preserving these criteria. However, the process of production, distribution, assembly and installation, may create conditions of bacterial proliferation, which may lead to odor problems and water contamination;
- it is therefore strongly recommended to sanitize the products. See Sanitization [→Page 75];
- maximum cleanliness is recommended during the assembly and installation;
- for disinfection, use Sodium or Calcium Hypochlorite and perform a manual regeneration.

3 Description

3.1 Technical specifications

Design specifications/ratings

Valve body	Brass
Rubber components	EP or EPDM
Weight (valve with controller)	2.5 kg
Recommended operating pressure	1.4 - 8.6 bar
Maximum inlet pressure	8.6 bar
Hydrostatic test pressure	20 bar
Water temperature	1 - 43°C
Water temperature for HW volumetric	1 - 65°C
Water temperature for HW time clock...	1 - 82°C
Ambient temperature	5 - 40°C

Flow rates (3.5 bar inlet - valve only)

Continuous service flow ($\Delta p = 1$ bar)	4.5 m ³ /h
Peak service flow ($\Delta p = 1.7$ bar)	5.9 m ³ /h
Cv*	5.2 gpm
Kv*	4.5 m ³ /h
Maximum backwash flow ($\Delta p = 1.8$ bar)	1.6 m ³ /h

*Cv: Flow rate in gpm across the valve at a pressure drop of 1 psi at 60°F.

*Kv: Flow rate in m³/h across the valve at a pressure drop of 1 bar at 15.5°C.

Valve connections

Tank Thread	2½" - 8NPSM
Inlet/Outlet	¾" or 1"
Riser tube	26.7 mm O.D., 1.05" tube
Drain line	½" O.D.
Brine line (1650)	⅜"

Electrical

Power supply	230 VAC, 50/60 Hz, 15 VA
Transformer output voltage	24 VAC, 10 VA max.
Motor input voltage	24 VAC
Controller input voltage	24 VAC
Controller max. power consumption	5 W

Protection rating	IP 22
Power supply	100 to 240 VAC, 50/60 Hz, 0.8 A, Class II
Transient overvoltages	Within the limits of category II
Pollution Degree	3

Temporary overvoltages must be limited in duration and in frequency.

Environmental conditions

- Indoor use only;
- temperature from 5°C to 40°C;
- maximum relative humidity 80% for temperatures up to 31°C decreasing linearly to 50% relative humidity at 40°C;
- mains supply voltage fluctuations up to ±10% of the nominal voltage.

3.2 Performance flow rate characteristics

The graph shows the pressure drop created by the valve itself at different flow rates. It allows predetermining the maximum flow rate going through the valve depending on the system settings (inlet pressure etc). It also allows to determine the valve pressure drop at a given flow rate, and therefore to evaluate the system pressure drop vs flow rate.

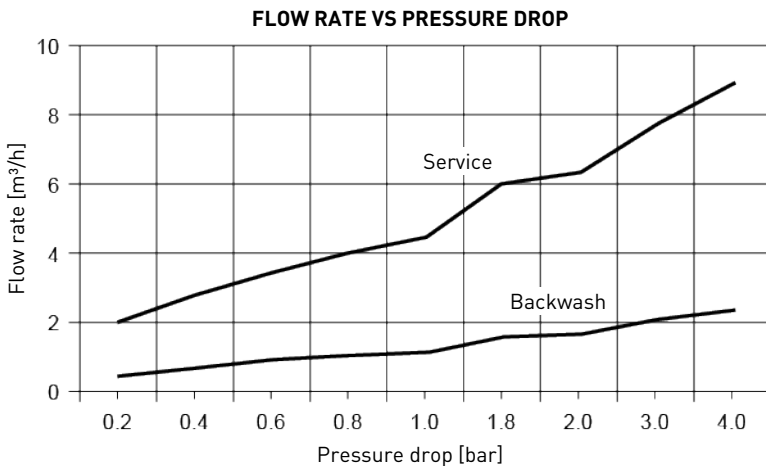

3.3 Outline drawing

3.3.1 SXT controller

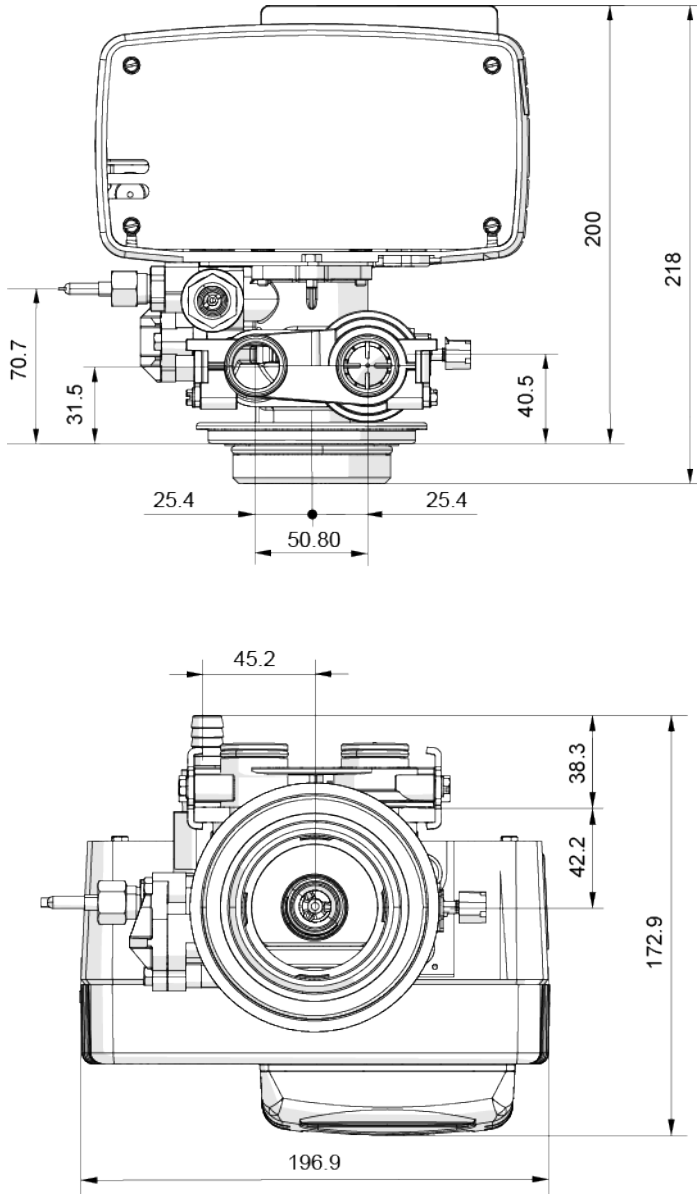

3.3.2 MECH controller

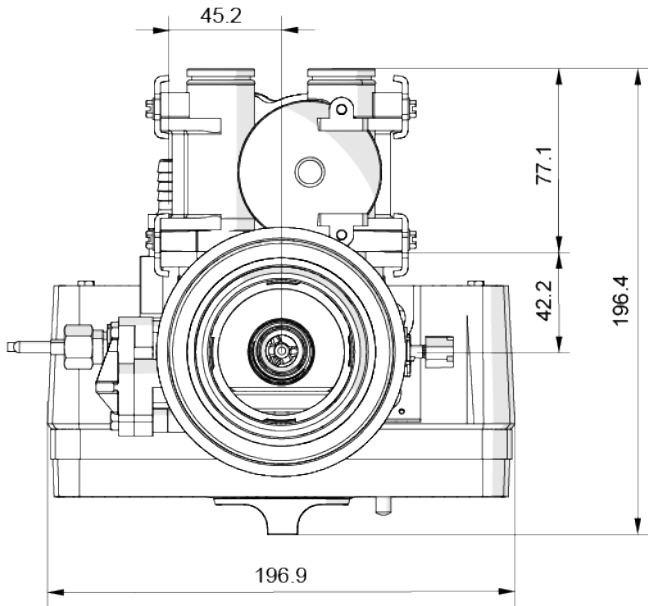
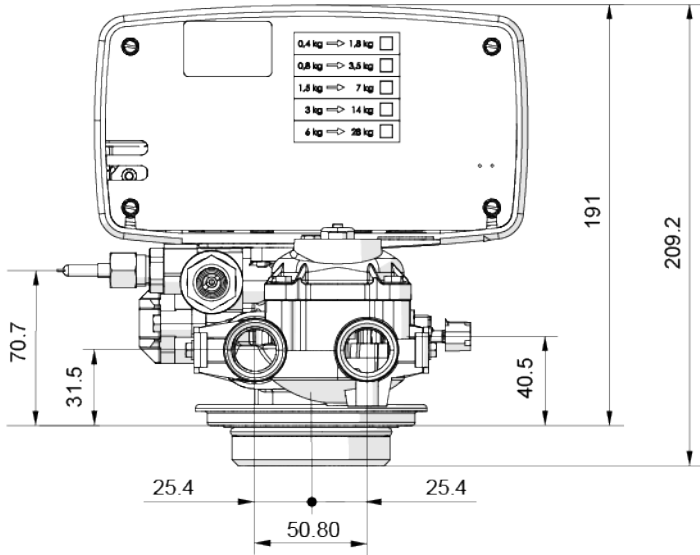

3.4 Components description and location

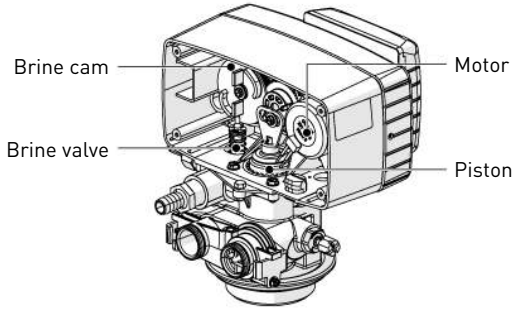

3.4.1 SXT controller

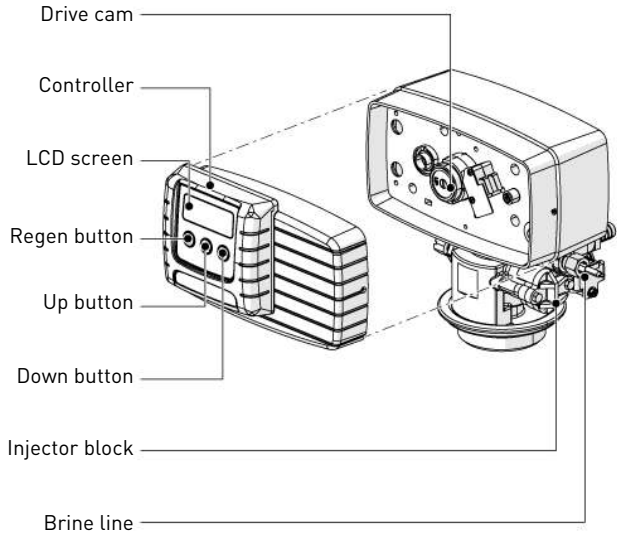

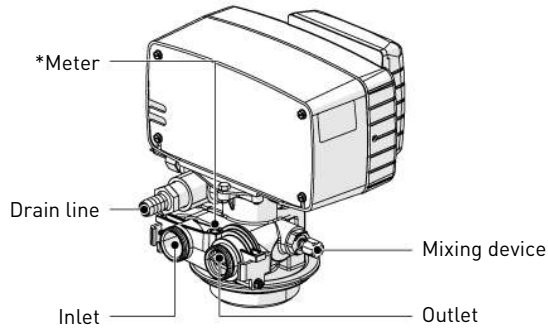

*Not included in case of timeclock

3.4.2 MECH controller

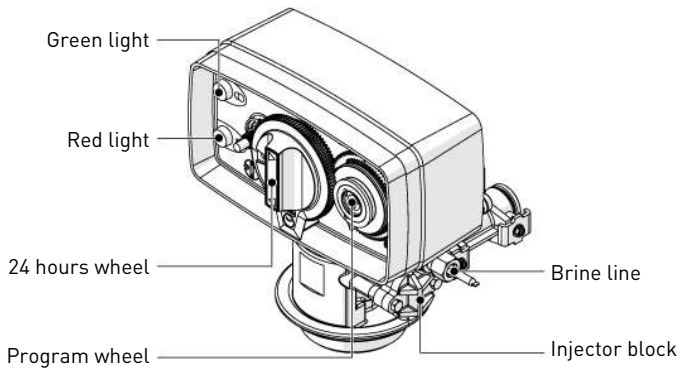

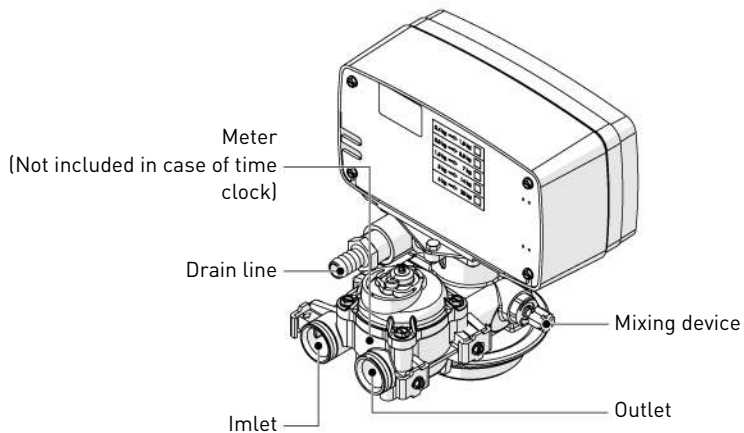

3.5 System regeneration cycle

Info



This valve allows to do filtration and down flow regenerations.

3.5.1 Downflow regeneration cycle (5-cycles operation)

Service — normal use

Untreated water is directed down through the resin bed and up through the riser tube. The hardness ions attach themselves to the resin and are removed from the raw water by being exchanged on the resin beads by sodium ions. The water is conditioned as it passes through the resin bed.

Backwash — cycle C1

The flow of water is reversed by the valve and directed down the riser tube and up through the resin bed. During the backwash cycle, the bed is expanded and debris is flushed to the drain, while the media bed is remixed.

Brine draw & slow rinse — cycles C2

The valve directs water through the brine injector and brine is drawn from the brine tank. The brine is then directed down through the resin bed and up through the riser tube to the drain. The hardness ions on the resin beads are replaced by sodium ions and are sent to the drain. The resin is regenerated during the brine cycle. When the air check valve closes, brine drawing finishes, and then, the slow rinse phase starts.

Second backwash — cycle C3 (Double backwash units only)

The flow of water is reversed by the valve and directed down the riser tube and up through the resin bed. During the backwash cycle, the bed is expanded and debris is flushed to the drain, while the media bed is remixed.

Rapid rinse — cycle C4

The valve directs water down through the resin bed and up through the riser tube to the drain. Any residual brine is rinsed from the resin bed, while the media bed is re-compacted.

Brine tank refill — cycle C5

Water is directed to the brine tank, at a rate controlled by the refill controller [BLFC], to create brine for the next regeneration. During brine refill, treated water is already available at the valve outlet.

Info



For illustration purpose only. Always verify inlet and outlet marking on the valve.

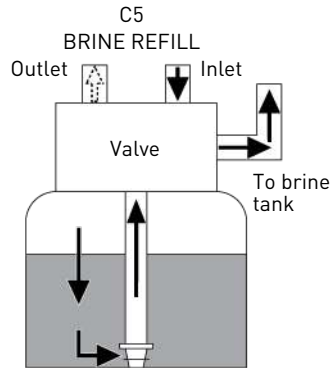
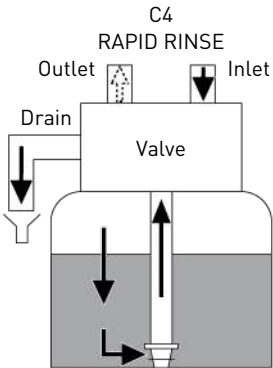
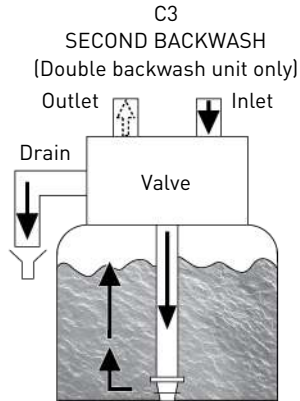
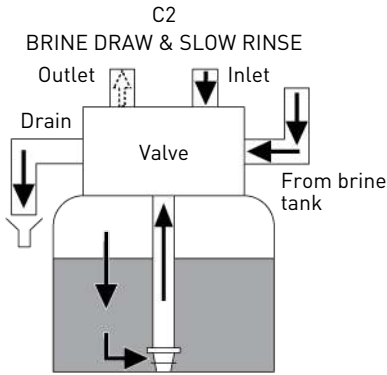
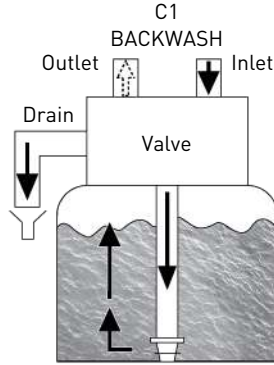
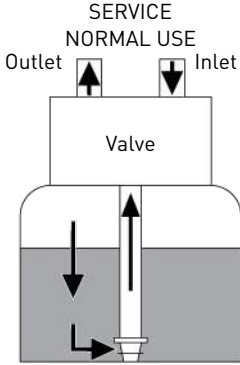

Untreated water

3.5.2 Filter cycle (3-cycles operation)

Service — normal use

Untreated water is directed down through the filter media and up through the riser tube. The impurities are retained by the media. The water is filtered as it passes through the media.

Backwash — cycle C1

The flow of water is reversed by the valve and directed down through the riser tube and up through the filter media. During the backwash cycle, the filter bed is expanded and debris is flushed to the drain, while the media bed is remixed.

Rapid rinse — cycle C2

The valve directs water down through the filter media and up through the riser tube to the drain. The media bed is getting re-compacted.

Info



For illustration purpose only. Always verify inlet and outlet marking on the valve.

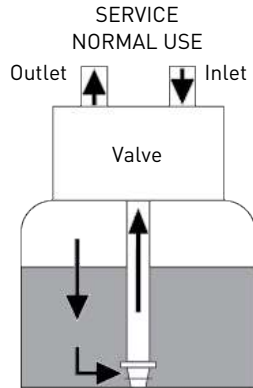
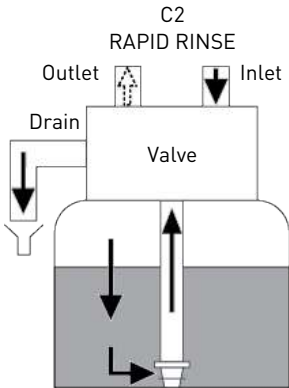
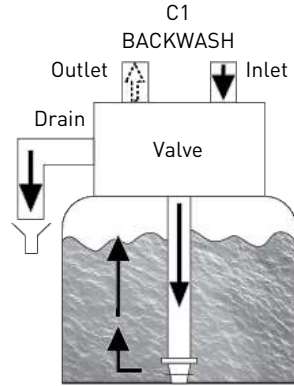
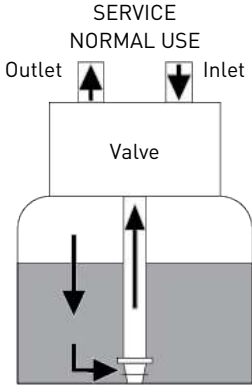

→ Untreated water

3.6 Special configurations

3.6.1 SXT controller - Configurations for softener and filter

To configure the valve as softener or filter, the piston and the cycle cam must be set as shown below.

3.6.1.1 Softener

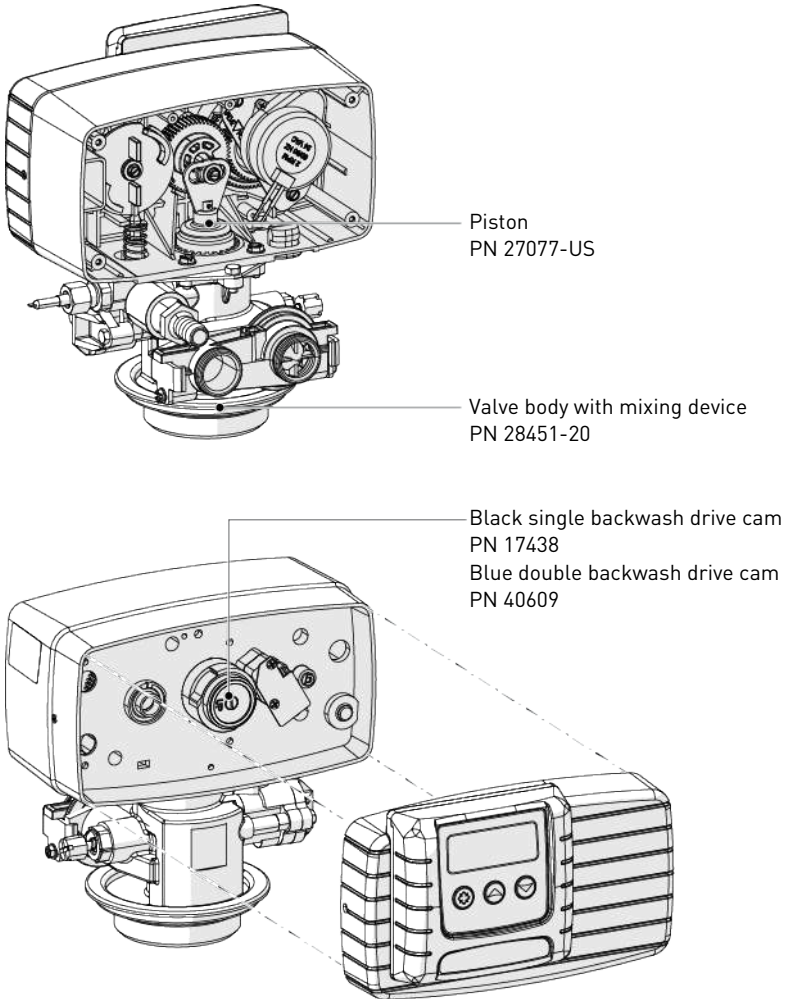

3.6.1.2 Filter

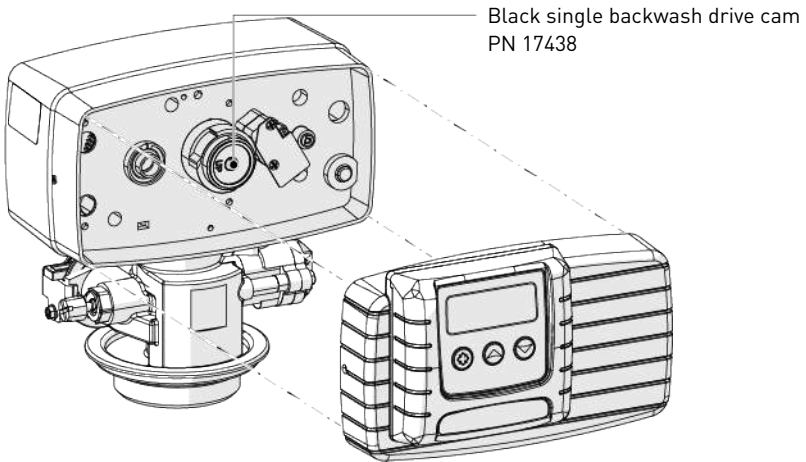
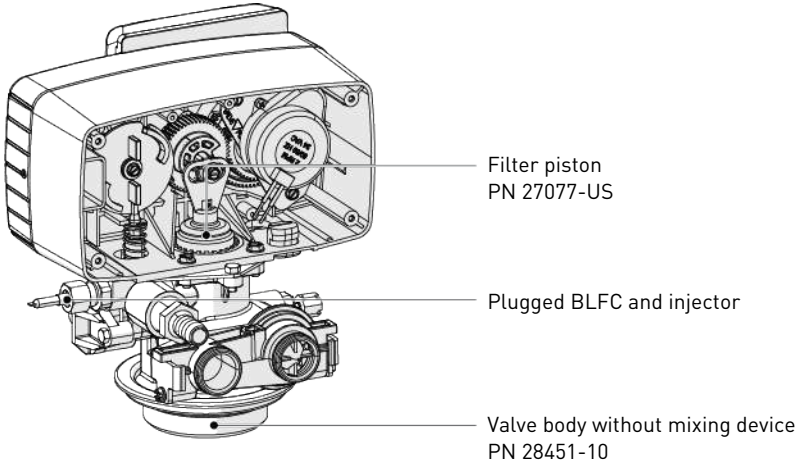

3.6.2 MECH controller - Configurations for volumetric and time clock softeners

To configure the valve as volumetric or time clock softener, the 24 hours gear, the skipper or program wheel and the meter must be set as shown below.

3.6.2.1 Volumetric

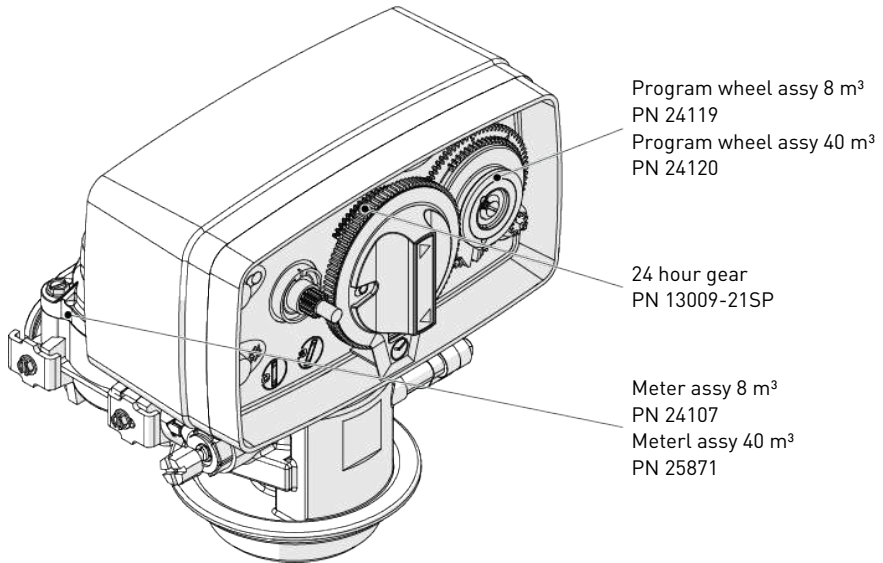

3.6.2.2 Time clock

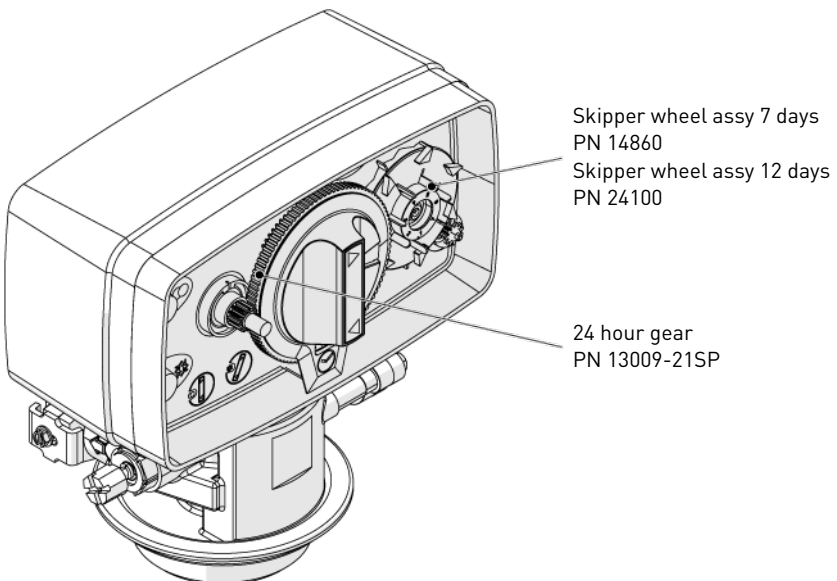

3.7 Options available on the valve

Mixing device

The valve can be equipped with a mixing device (1) whose function is to regulate the hardness of the water at the outlet. The mixing can be set from 0% to 50% of hard water (i.e. 0 turn = 0% of hard water with 100% of treated water and 1-½ turn = 50% of hard water with 50% of treated water).

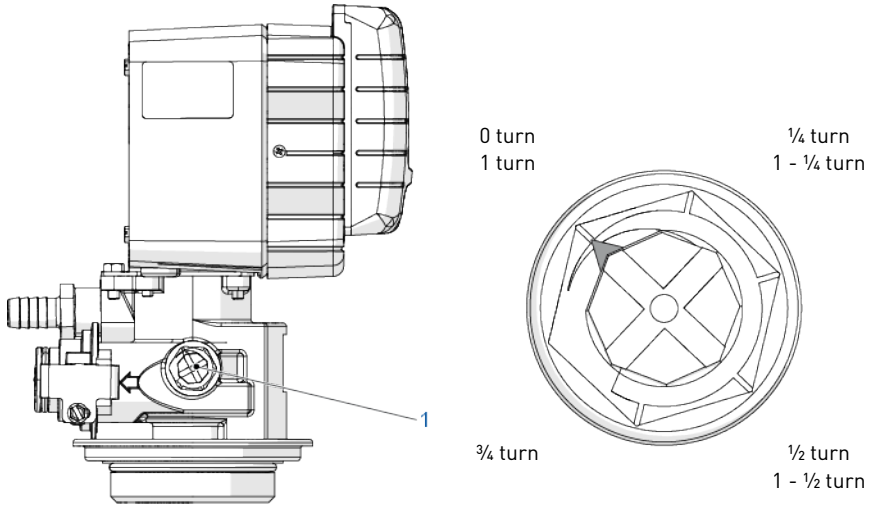

Low water usage piston (L.W.U.)

With this piston, water consumption during regeneration can be reduced.

4 System sizing

4.1 Recommended Injector/DLFC/BLFC-Valve configuration

Brine syst.	Tank Diameter	Resin volume	Injector				DLFC	BLFC	
	[in]	L	DF	Color	UF	Color	[gpm]	DF [gpm]	UF [gpm]
4600/ 1600	6	5 – 8	0	Red	N/A	N/A	0.8	0.125	N/A
	7	9 – 14					1.2	0.25	
	8	15 – 21	1	White			1.5		
	9	22 – 28					2.0		
	10	29 – 42					2.4		
	12	43 – 56	2	Blue			3.5	0.50	
	13	57 – 70					4.0		

4.2 Sizing a softener (single unit)

4.2.1 Parameters to be considered

Whenever installing a softener, it is preferable to have full water analysis to ensure the inlet water content will not affect the resin bed.

Tip



Please consult your resin manufacturer specification !

To ensure that no additional pretreatment prior to softening is required.

The below sizing method can be applied for both residential and industrial softeners.

The sizing of a softener must be based upon certain parameters:

- inlet water hardness;
- peak flow rate and nominal flow rate;
- service velocity;
- salt dosage.

The softening and regeneration reactions are driven under certain conditions. To allow these reactions to take place, make sure that the velocity is convenient during the different phases for proper ion exchange. This velocity is given in the resin manufacturer specifications sheet.

Depending on the inlet water hardness, the service velocity for standard softening must be between:

Service velocity [bed volume per hour]	Inlet water hardness [mg/L as CaCO ₃]	°f °TH	°dH
8 - 40	<350	<35	<19.6
8 - 30	350 to 450	35 - 45	19.6 - 25.2
8 - 20	>450	>45	>25.2

Caution - material



Risk of leakage due to unrespected service velocity !

Failure to respect the service velocity will lead to hardness leakage or even total softener inefficiency.

Note that the water supply piping size may also be useful when estimating the nominal flow rate, since the size of the piping allows a maximum flow rate to pass. Assuming the maximum velocity of water in pipes is about 3 m/s, a good estimation for most common pressure [3 bar] and temperature [16°C] is:

Piping size (internal diameter)		Max. flow rate
[in]	[mm]	[m ³ /h at 3 m/s]
0.5	12	1.22
0.75	20	3.39
1	25	5.73
1.25	32	8.69
1.5	40	13.57
2.0	50	21.20
2.5	63	34.2
3.0	75	49.2

4.2.2 Determining the required volume of resin

When sizing a softener, make sure that the volume of resin in the tank (bed volume) will be sufficient so that even when the peak flow rate is reached, the velocity is still between the above values depending on the hardness. When sizing a softener, always choose the resin volume and tank size based on the peak flow rate but not on the nominal flow rate.

Caution - material



Risk of leakage due to wrong sizing !

Sizing on the nominal flow rate without taking the peak flow rate into account would result in choosing smaller tank size and resin volume, and may lead in severe hardness leakage during the service cycle when the peak flow is reached.

The maximum softened water flow rate that a softener can produce is given by the following formula:

$$Q_{\text{service max}} = F_{\text{Sservice}} \times BV$$

with:

$Q_{\text{service max}}$: service flow rate [m³/h]

F_{Sservice} : service velocity [BV/h]

BV: bed volume of resin [m³]

Knowing this required volume of resin, it is possible now to determine the needed tank. Note that at least a third of the total volume of the tank must be kept as free space so that the bed expansion during backwash is sufficient to ensure correct cleaning of the resin.

4.2.3 Resin exchange capacity and capacity of the unit

The resin exchange capacity and capacity of the unit are two different things that should not be confused. The resin exchange capacity is the amount of Ca^{2+} and Mg^{2+} that can be retained by 1 litre of resin, which will depend on the resin type and salt dosage, whereas the capacity of the unit is the capacity of the system, which will depend on the volume of resin and resin exchange capacity.

Knowing the required volume of resin, it is possible to determine the exchange capacity of the unit. The capacity of the unit can be expressed in different ways:

- the mass capacity, which corresponds to the weight in equivalent CaCO_3 that can be fixed on the resin, expressed in kg as CaCO_3 ;
- the volume capacity, which represents the maximum amount of water that can be treated between 2 regenerations. This last capacity takes into account the hardness of the water to be treated and is expressed in m^3 or litre;
- the combined capacity, which represents the volume of water that could be treated between 2 regenerations if the inlet hardness is 1 °f or °dH. This capacity is expressed in °f.m³ or °dH.m³.

The resin exchange capacity will depend on the amount of salt to be injected into the resin bed during the regeneration. This amount of salt is given in grams per litre of resin. The next table is showing the resin exchange capacity in function of the amount of salt for a system with standard efficiency regeneration.

Resin exchange capacity as a function of the salt dosage:

Salt amount [g/L _{resin}]	Corresponding resin exchange capacity [g/L _{resin}] as CaCO_3	°f.m ³ [per L _{resin}]	°dH.m ³ [per L _{resin}]
50	29.9	2.99	1.67
60	34	3.4	1.9
70	37.5	3.75	2.09
80	40.6	4.06	2.27
90	43.4	4.34	2.42
100	45.9	4.59	2.56
110	48.2	4.82	2.69
120	50.2	5.02	2.8
130	52.1	5.21	2.91
140	53.8	5.38	3.01
150	55.5	5.55	3.1
170	58.5	5.85	3.27
200	62.7	6.27	3.5
230	66.9	6.69	3.74
260	71	7.1	3.97
290	75.3	7.53	4.21

To calculate the system mass capacity:

$$M_{\text{capacity}} = V_{\text{resin}} \times C_{\text{resin ex}}$$

with:

M_{capacity} : system mass capacity [g as CaCO_3]

V_{resin} : volume of resin [L]

$C_{\text{resin ex}}$: resin exchange capacity [g/L_{resin} as CaCO_3]

To calculate the system combined capacity:

$$C_{\text{capacity}} = V_{\text{resin}} \times C_{\text{cor resin ex}}$$

with:

C_{capacity} : system combined capacity [$^\circ\text{f}\cdot\text{m}^3$ or $^\circ\text{dH}\cdot\text{m}^3$]

V_{resin} : volume of resin [L]

$C_{\text{cor resin ex}}$: corresponding resin exchange capacity [$^\circ\text{f}\cdot\text{m}^3/\text{l}$ or $^\circ\text{dH}\cdot\text{m}^3/\text{l}$]

To calculate the system volume capacity:

$$V_{\text{capacity}} = M_{\text{capacity}} / TH_{\text{inlet}}$$

with:

V_{capacity} : system volume capacity [m^3]

Or

M_{capacity} : system mass capacity [g as CaCO_3]

C_{capacity} : system combined capacity [$^\circ\text{f}\cdot\text{m}^3$ or $^\circ\text{dH}\cdot\text{m}^3$]

$$V_{\text{capacity}} = C_{\text{capacity}} / TH_{\text{inlet}}$$

TH_{inlet} : inlet water hardness [mg/L as CaCO_3 or $^\circ\text{f}$ or $^\circ\text{dH}$]

Mandatory



If a mixing device is set on the valve before meter, use $TH = TH_{\text{INLET}} - TH_{\text{OUTLET}}$!

Having determined the previous capacity allows the operator to know the service cycle duration.

4.2.4 Valve configuration

Knowing the volume of resin, tank size and specifications of the resin, it is possible to determine the required valve configuration. The resin specification will give the backwash velocity, as well as the brine draw and slow rinse velocity that must be respected in order to ensure a proper regeneration of the unit. From this data, determine the required backwash flow rate as well as the brine draw and slow rinse flow rate. In most cases, the fast rinse flow rate will be the same as the backwash flow rate, however for certain valve types the fast rinse flow rate will be the same as the service flow rate.

To determine the backwash flow rate:

$$Q_{\text{backwash}} = F_{\text{Sbackwash}} \times S$$

with:

Q_{backwash} : backwash flow rate [m^3/h]

$F_{\text{Sbackwash}}$: backwash velocity [m/h]

S: Tank cross section area [m^2]

The DLFC installed on the valve has to limit the backwash flow rate to the above calculated flow rate.

To determine the injector size:

The velocities to be respected for brine draw and slow rinse are given on the resin manufacturer specifications. Generally speaking, the injector has to allow a flow rate of about 4BV / h (corresponding to the flow rate of brine being drawn added to the flow rate of raw water passing through the injector nozzle to create the suction effect).

$$Q_{inj} = 4 \times BV / h$$

with:

Q_{inj} : total flow rate passing through the injector [L/h]

BV: bed volume of resin [L]

Info



This value does not correspond to the brine draw flow rate but to the total flow rate passing through the injector.

Refer to the injector diagrams at the inlet pressure in order to check if the injector will give a correct flow rate.

See chapters Salt amount definition [→Page 35] and Injector flow rates [→Page 36].

4.3 Cycle time calculation

4.3.1 SXT controller

From this point, the volume of resin, the tank size, the capacity of the softener and the valve configuration are determined. Next step is to calculate the regeneration cycle duration, which depends on the valve configuration and once again on the resin specifications.

Info



Several parameters need, potentially, to be adjusted.

For cycle time calculation the valve configuration must be known, which depends on:

- the tank size;
- the resin specifications for the velocity for backwashing the resin bed;
- the velocity of water for brine draw, slow rinse and fast rinse.

Further information needed for cycle time calculation are:

- the resin volume previously determined;
- the salt amount used per regeneration;
- the volume of water to use for backwash, brine draw, slow rinse and fast rinse.

To calculate the backwash duration:

$$T_{\text{backwash}} = (N_{\text{BVbw}} \times \text{BV}) / Q_{\text{DLFC}}$$

with:

T_{backwash} : backwash duration [min]

N_{BVbw} : number of bed volume for backwash

BV: bed volume [L]

Q_{DLFC} : drain line flow controller size [L/min]

Info



The typical value of the volume of water to be used for backwash is between 1.5 and 4 times the bed volume, depending on the inlet water quality.

To calculate the brine draw duration:

Knowing the injector draw flow rate at the working pressure:

$$T_{\text{brine draw}} = V_{\text{brine}} / Q_{\text{draw}}$$

with:

$T_{\text{brine draw}}$: brine draw duration [min]

V_{brine} : brine volume to be drawn [L], see SXT controller [→Page 35].

Q_{draw} : injection draw flow rate [L/min]

Tip



Multiply the amount of salt in kg by 3 to get a approximation of the brine volume to draw !

To calculate slow rinse duration:

The volume of water to be used for slow rinse is given in the resin manufacturers specifications. Generally speaking, it is advised that between 2 and 4 BV of water is used to perform the slow rinse after brine draw. The slow rinse cycle allows brine to be pushed slowly through the resin bed, allowing the resin to be in contact with brine for sufficient time and therefore to be regenerated.

Refer to the injector curve at the common working pressure to determine the slow rinse duration.

$$T_{\text{slow rinse}} = (N_{\text{BVsr}} \times \text{BV}) / Q_{\text{SR}}$$

with:

$T_{\text{slow rinse}}$: slow rinse duration [min]

N_{BVsr} : number of bed volume for slow rinse

BV: bed volume [L]

Q_{SR} : injector slow rinse flow rate [L/min]

To calculate fast rinse duration:

The fast rinse is aimed at eliminating an excess of salt in the resin bed and also recompacting the resin in the tank.

Depending on the valve type, the fast rinse flow rate is controlled by the DLFC or it has about the same flow rate as in service. The fast rinse velocity can be the same as the service velocity, and the volume of water to be used for the fast rinse is generally between 1 and 10 BV depending on the salt dosage.

$$T_{\text{fast rinse}} = (N_{\text{BVfr}} \times \text{BV}) / Q_{\text{DLFC}}$$

with:

$T_{\text{fast rinse}}$: fast rinse duration [min]

N_{BVfr} : number of bed volume for fast rinse

BV: bed volume [L]

Q_{DLFC} : drain line flow controller size [L/min]

To calculate the refill duration:

The refill flow rate is controlled by the refill controller (BLFC). The relation between the BLFC size, the tank size and the resin volume is given in the valve specifications.

To calculate the refill duration:

$$T_{\text{refill}} = V_{\text{WB}} / Q_{\text{BLFC}}$$

with:

T_{refill} : refill duration [min]

V_{WB} : Volume of water to be refill to prepare the brine [L]

Q_{BLFC} : BLFC size [L/min]

$$V_{\text{WB}} = D_{\text{Salt}} \times \text{BV} / S_{\text{sol}}$$

with:

V_{WB} : Volume of water to be refill to prepare the brine [L]

D_{Salt} : Salt dosage per litre of resin [g/L]

BV: Bed volume [L]

S_{sol} : 360g/L - Solubility of salt per litre of water

Tip



When calculating the time required to draw the brine, take into account that the volume of brine [Vbrine] will be 1.125 bigger than the volume of water refilled !

4.3.2 MECH controller

Info



The mechanical controller uses fixed times.

4.4 Salt amount definition

The salt settings are controlled through the controller programming. See Resin exchange capacity and capacity of the unit [->Page 31].

4.5 Injector flow rates

The following graphics represent the injectors flow rate as a function of the inlet pressure for the different injector sizes.

4.5.1 1600 injectors

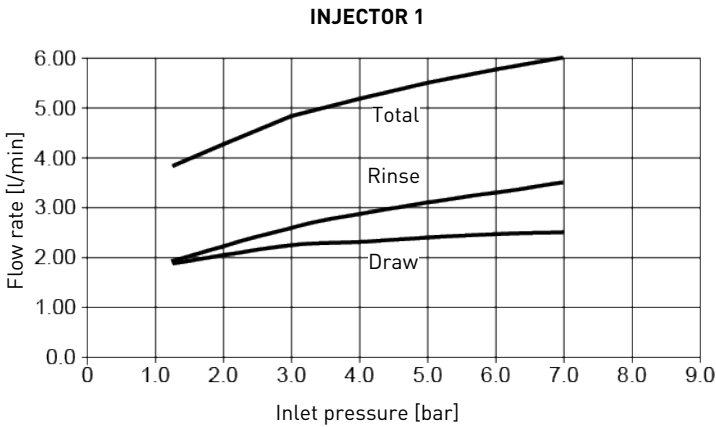
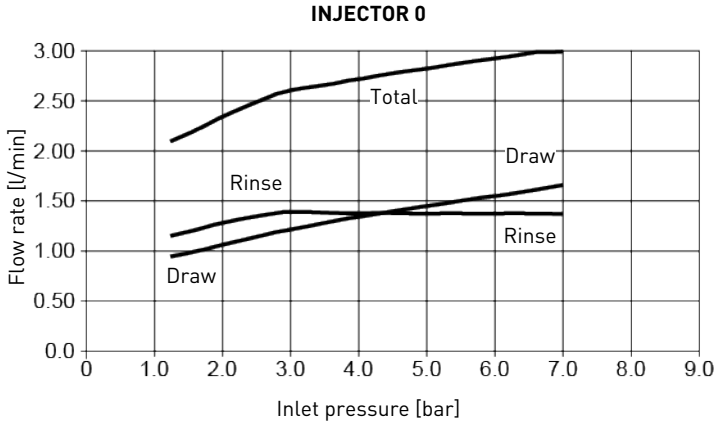

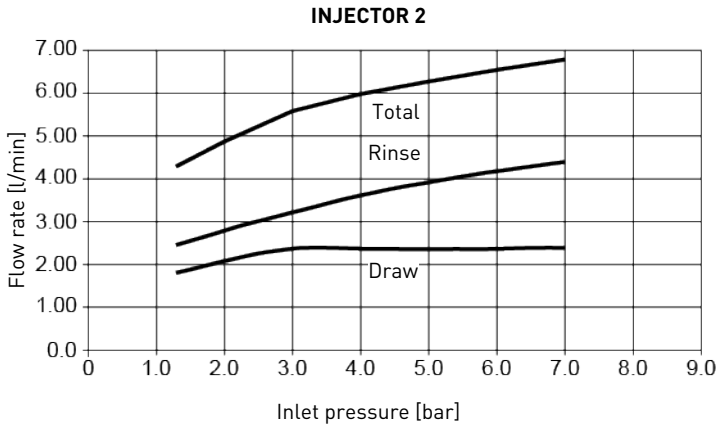

4.5.2 1650 injectors

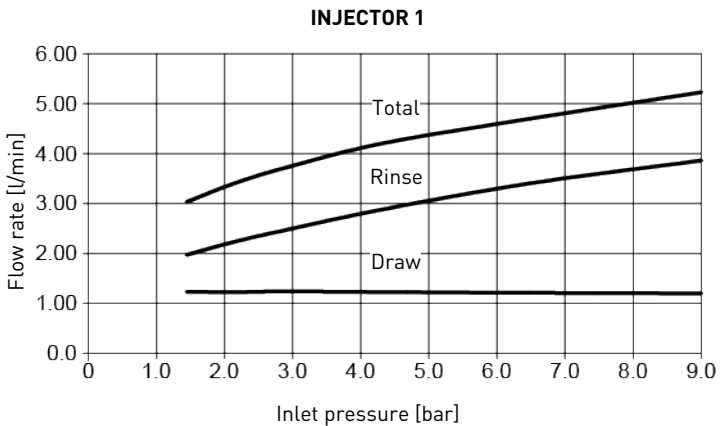
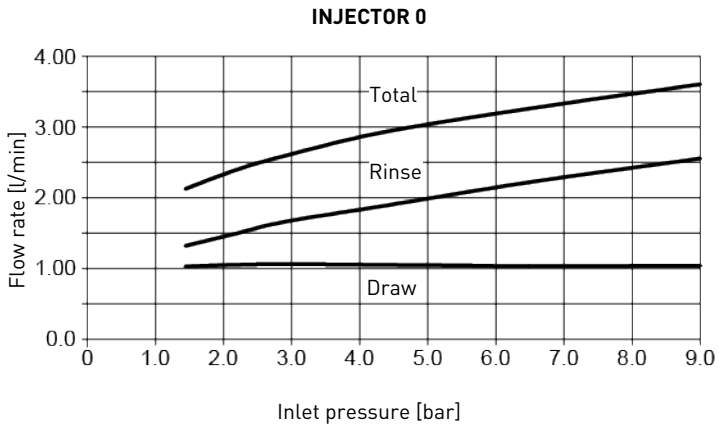

INJECTOR 2

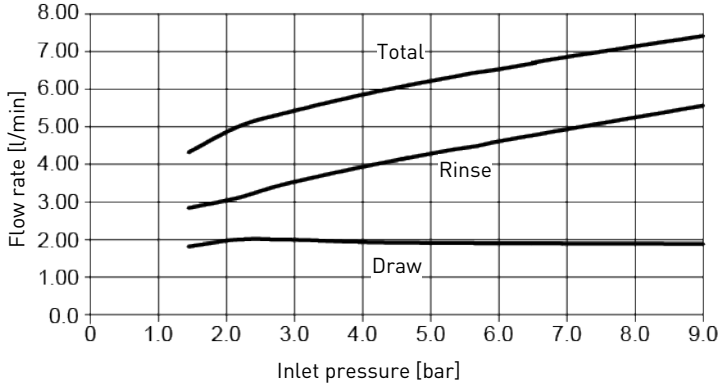

5 Installation

CAUTION



Risk of injury due to electrical shock or pressurized elements !

It is strictly forbidden for not qualified personal, to accede to system's internal parts to perform any kind of technical action.

Be sure to disconnect the electrical power, close the water inlet and depressurize the system before opening the front cover to access internal parts !

5.1 Warnings

The manufacturer will not be held liable for any damages to people or properties resulting from an improper use of the device not compliant with the following instructions.

Whenever this guide doesn't clarify all doubts about installation, service or maintenance, please contact the technical support of the company that has installed the device.

Device installation must be done by a qualified technician according to the current standards and regulations, using tools compliant with a device for a safety use and referring to that technician also for device maintenance.

In case of out of order or malfunction, before performing any kind of action on the device, please ensure to have disconnected the transformer from the power source, to shut off inlet water supply to the valve and to drain water pressure opening a tap down-line of the valve.

1. Be careful when removing the valve from the box and during subsequent handling, weight is liable to cause damage to property and persons in case of accidental impact.
2. Before sending the water on the valve, make sure that all plumbing connections are tight and properly implemented in order to avoid dangerous leaks of pressurized water.
3. Use caution when installing welded metal piping near the valve, the heat may damage the plastic body of the valve and the bypass.
4. Be careful not to let the full weight of the valve on fittings, pipes or bypass.
5. Make sure that the environment in which the valve is installed does not reach freezing temperatures of the water, the valve may be damaged.
6. Make sure that the tank containing the resin is vertical; otherwise the resin could enter in the valve and damage it.

5.2 Safety notices for installation

- Observe all warnings that appear in this manual;
- only qualified and professional personnel are authorized to carry out installation work.

5.3 Installation environment

5.3.1 General

- Use only brine salts designed for water softening. Do not use ice melt, block, or rock salts;

- keep the media tank in an upright position. Do not turn on its side, upside down, or drop it. Turning the tank upside down may cause media to enter the valve or might clog the upper screen;
- follow State and local codes for water testing. Do not use water that is micro-biologically unsafe or of unknown quality;
- when filling the media tank with water, first place the valve in the backwash position, then partly open the valve. Fill the tank slowly to prevent media from exiting the tank;
- when installing the water connection (bypass or manifold), first connect to the plumbing system. Allow heated parts to cool and cemented parts to set before installing any plastic parts. Do not get primer or solvent on O-rings, nuts, or the valve.

5.3.2 Water

- Water temperature must not exceed 43°C for standard version, 65°C for volumetric hot water version and 82°C for time clock hot water version;
- a minimum of 1.4 bar (dynamic pressure on injector) of water pressure is required for the valve to operate effectively.

Mandatory



Do not exceed a maximum of 8.6 bar inlet pressure. In such cases, it is necessary to install a pressure regulator upstream the system.

5.3.3 Electrical

There are no user-serviceable parts in the AC/AC or AC/DC transformer, motor, or controller. In the event of a failure, these should be replaced.

- All electrical connections must be completed according to local codes;
- use only the power AC/AC or AC/DC transformer that is supplied;

Mandatory



The use of any other power transformer than the one supplied void the warranty of all electronic parts of the valve!

- the power outlet must be grounded;
- to disconnect power, unplug the AC/AC or AC/DC transformer from its power source;
- an uninterrupted current supply is required. Please make sure that the voltage supply is compatible with the unit before installation;
- make sure the controller power source is plugged in;
- if the electrical cable is damaged, it is imperative that it is replaced by qualified personnel.

5.3.4 Mechanical

Caution - material



Risk of damage due to wrong lubricant use !

Do not use petroleum-based lubricants such as vaseline, oils, or hydrocarbon-based lubricants.

Use only approved silicone grease or soapy water !

- All plastic connections should be hand-tightened. PTFE (plumber's tape) may be used on connections that do not use an O-ring seal. Do not use pliers or pipe wrenches;
- existing plumbing should be in a good shape and free from limescale. In case of doubt, it is preferable to replace it;
- all plumbing must be completed according to local codes and installed without tension or bending stresses;
- soldering near the drain line should be done before connecting the drain line to the valve. Excessive heat will cause interior damage to the valve;
- do not use lead-based solder for sweat solder connections;
- the riser tube should be cut flush with the top of the tank. Slightly bevel the ridge in order to avoid deterioration of the seal whilst fitting the valve;
- the drain line must be a minimum of 12.7 mm (½") in diameter. Use 19 mm (¾") pipe if the backwash flow rate is greater than 26.5 lpm or the pipe length is greater than 6 m;
- do not support the weight of the system on the valve fittings, plumbing, or the bypass;
- it is not recommended to use sealants on the threads. Use PTFE (plumber's tape) on the threads of the drain elbow, and other NPT/BSP threads;
- the installation of a pre-filter is always recommended (100µ nominal);
- valve inlet/outlet must be connected to main piping via flexible.

5.4 Integration constraints

Location of a water treatment system is important. The following conditions are required:

CAUTION



The surface for installation (platform or floor) must be solid, flat and level.

Mandatory



Drain must be capable of handling a maximum backwash flow rate of 19 L/min.

- locate the softener as close as possible from drain discharge point and within 12.2 m maximum of drain discharge point, respecting minimum drain line diameter advises given at chapter Drain line connection [→Page 49];
- room to access equipment for maintenance and adding brine (salt) to tank;
- constant electrical supply to operate the controller;

- total minimum pipe run to water heater of 3 m to prevent backup of HW into system;
- always install check valve before water heater to protect the softener from HW return;
- local drain for discharge as close as possible;
- water line connections with shut off or bypass valves;
- must meet any local and state codes for site of installation;
- valve is designed for minor plumbing misalignments. Do not support weight of system on the plumbing;
- use flexible piping to connect main piping to softener;
- be sure all soldered pipes are fully cooled before attaching plastic valve to the plumbing.

5.5 Valve on tank assembly

1. Lubricate the seals with approved silicone grease.
2. Spin the valve **[1]** onto the tank **[2]**, ensuring the threads are not cross-threaded.
3. Rotate the valve **[1]** clockwise and freely, without using force until it comes to a stop.

Info



This stop position is considered point zero.

4. Rotate the valve **[1]** clockwise from point zero to between $\frac{1}{4}$ turn and $\frac{1}{2}$ turn.

Caution - material



Risk of damage due to excessive force !

Do NOT exceed 27 Nm of torque when installing the valve. Exceeding this limit may damage the threads and cause failure.

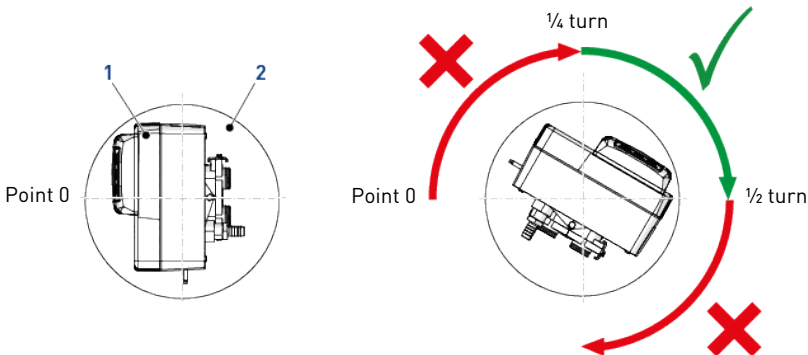

5.6 Valve connection to piping

The connections should be hand tightened using PTFE (plumber's tape) on the threads if using the threaded connection type.

In case of heat welding (metal type connection), the connections should not be made to the valve when soldering.

Tip



See chapter Components description and location to identify the connections.

When pressurized, any composite tank will expand both vertically and circumferential. In order to compensate the vertical expansion, the piping connections to the valve must be flexible enough to avoid overstress on the valve and tank.

5.6.1 Top-mounted valve installation

The valve and tank should not be supporting any part of the piping weight. This is hence compulsory to have the piping fixed to a rigid structure (e.g. frame, skid, wall...) so that the weight of it is not applying any stress on the valve and tank.

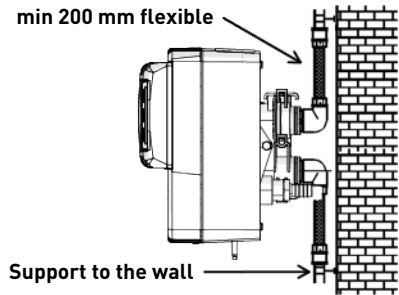
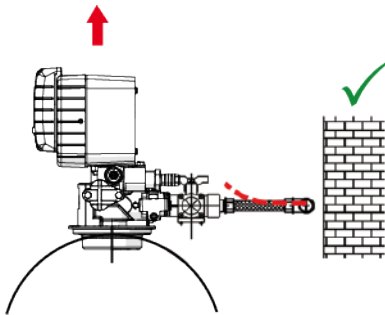

- The diagrams above illustrate how the flexible piping connection should be mounted;
- in order to adequately compensate the tank elongation the flexible tubes must be installed **horizontally**;
- should the flexible piping connection be installed in vertical position, instead of compensating the elongation, it will create additional stresses on the valve & tank assembly. Therefore this is to be avoided;
- the flexible piping connection must also be installed stretched, avoiding excessive length. For instance 20 – 40 cm is enough;
- excessively long and non-stretched flexible piping connection will create stresses on the valve and tank assembly when the system is pressurized, as illustrated in the below picture: on the left the assembly when the system is unpressurised, on the right the flexible piping connection when put under pressure tends to lift up the valve when stretching up. This configuration is even more dramatic when using semi-flexible piping;
- failure to provide enough vertical compensation may lead to different kinds of damage, either on the valve thread which is connected to the tank, or on the female thread connection of the tank. In some cases, damage may also be seen on the valve inlet and outlet connections;

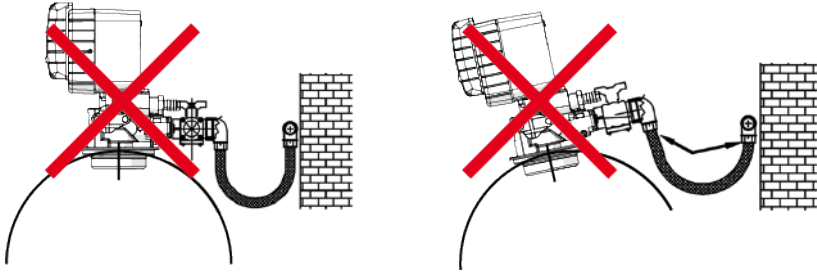

- in any case, any failure caused by improper installations and/or piping connections may void the warranty of Pentair products;
- in the same way, using lubricant* [→Page 44] on the valve thread is not allowed and will void the warranty for the valve and tank. Indeed using lubricant there will cause the valve to be over-torqued, which may lead to valve thread or tank thread damage even if the connection to piping has been done following the above procedure.

*Note: Use of petroleum-based grease and mineral based lubricant is totally forbidden, not only on the valve thread, since plastics used (especially Noryl) will highly suffer from contact with this type of grease, leading into structural damage hence to potential failures.

5.7 Block diagram and configuration example

Block diagram

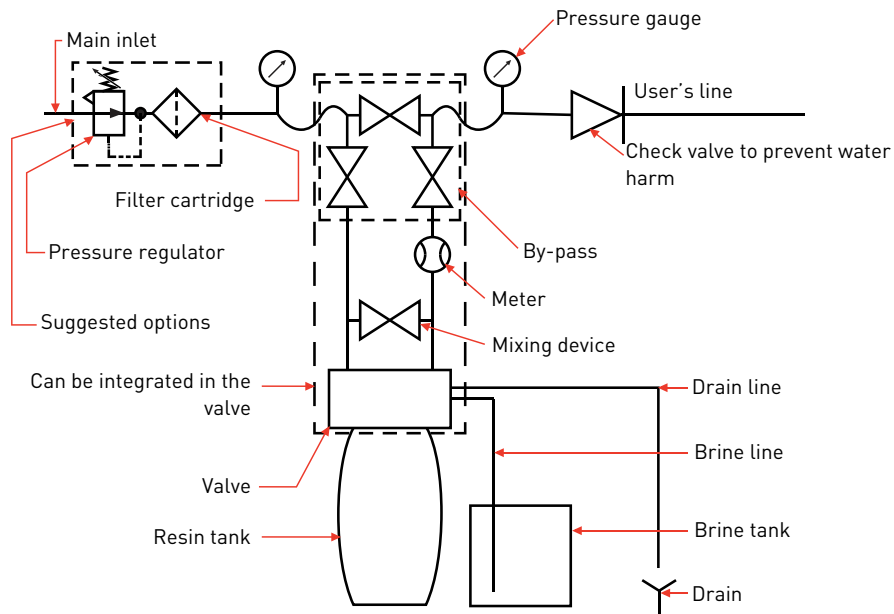

Top mounted configuration example

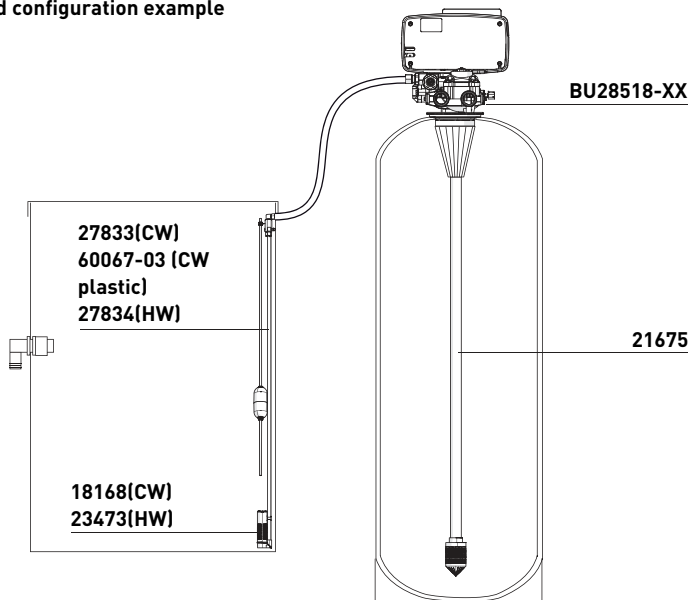

5.8 Regeneration flows

5.8.1 SXT controller

Metered immediate control

A meter immediate control measures water usage and regenerates the system as soon as the calculated system capacity is depleted. The control calculates the system capacity by dividing the unit capacity (typically expressed in °TH*m³ volume) by the feedwater hardness and subtracting the reserve. Meter Immediate systems generally do not use a reserve volume. A Meter Immediate control will also start a regeneration cycle at the programmed regeneration time if a number of days equal to the regeneration day override pass before water usage depletes the calculated system capacity.

Metered delayed control

A Meter Delayed Control measures water usage and regenerates the system at the programmed regeneration time after the calculated system capacity is depleted. As with Meter Immediate systems, the control calculates the system capacity by dividing the unit capacity by the feedwater hardness and subtracting the reserve. The reserve should be set to ensure that the system delivers treated water between the time the system capacity is depleted and the actual regeneration time. A Meter Delayed control will also start a regeneration cycle at the programmed regeneration time if a number of days equal to the regeneration day override pass before water usage depletes the calculated system capacity.

Time clock delayed control

A Time Clock Delayed Control regenerates the system on a timed interval. The control will initiate a regeneration cycle at the programmed regeneration time when the number of days since the last regeneration equals the regeneration day override value.

Day of the week control

This control regenerates the system on a weekly schedule. The schedule is defined in Master Programming by setting each day to either "OFF" or "ON." The control will initiate a regeneration cycle on days that have been set to "ON" at the specified regeneration time.

5.8.2 MECH controller

Volumetric

The controller monitors the volume of water used. Once it calculates that system capacity is reached, a regeneration cycle will be initiated immediately or at a pre-set time.

- Immediate control: The controller measures water usage and regenerates the system as soon as the system capacity is reached;
- delayed control: The controller measures water usage and regenerates the system, at the specified regeneration time (02h00), after the system capacity is reached.

Time clock control

This control regenerates the system on a weekly schedule. The schedule is defined on the skipper wheel. The control will initiate a regeneration cycle on days that have been set to "ON".

The system can be set to regenerate on one to every day of the week or on a 2, 3, 4, 6 or 12 days period.

5.9 Electrical connections

5.9.1 SXT controller

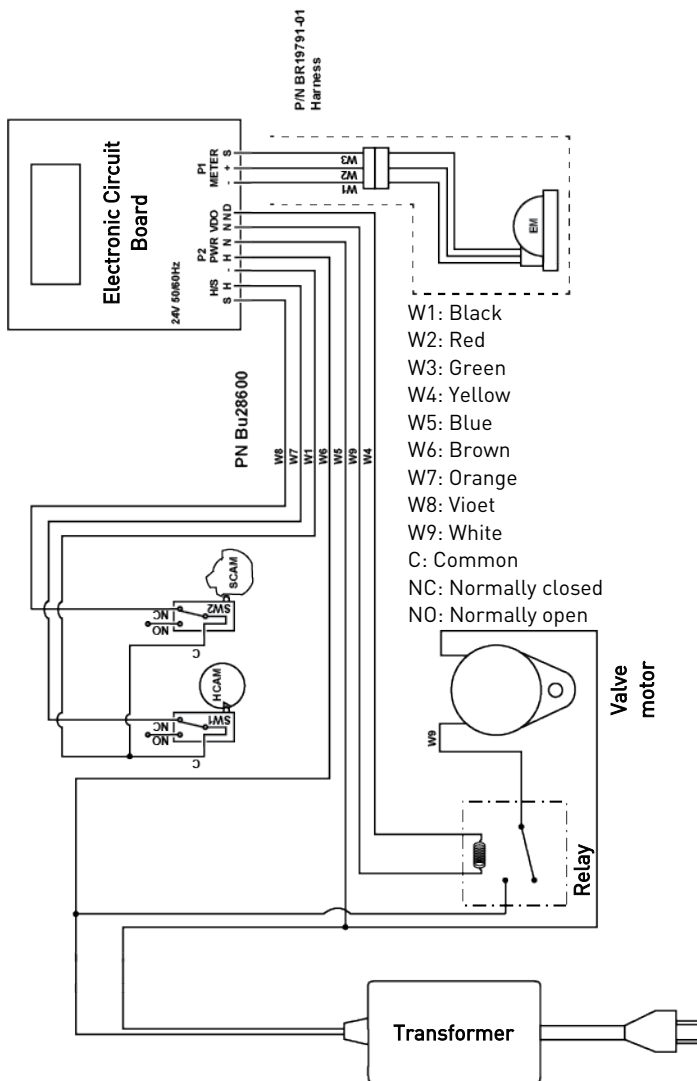

Info



The microswitches are connected on C and NC.

5.9.2 MECH controller

With lights

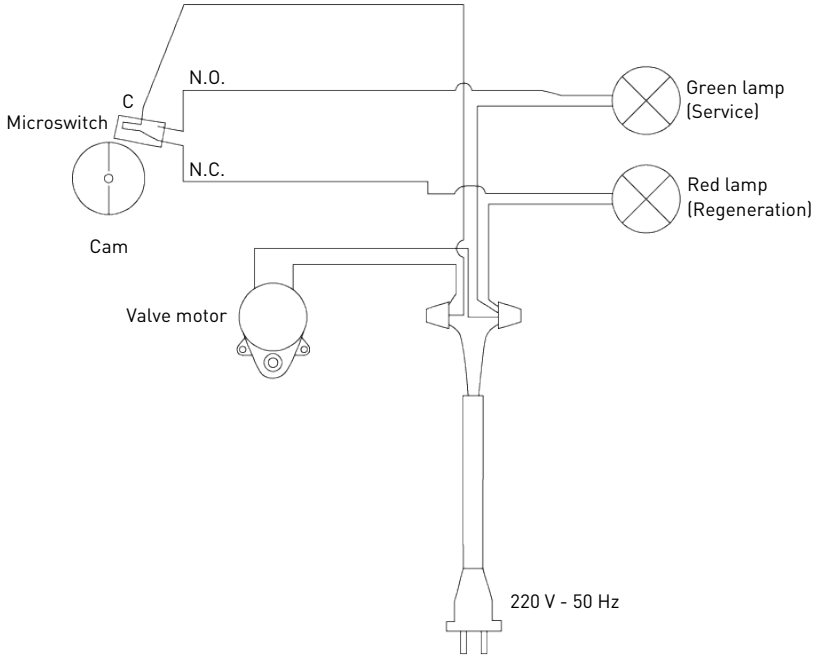

Without lights

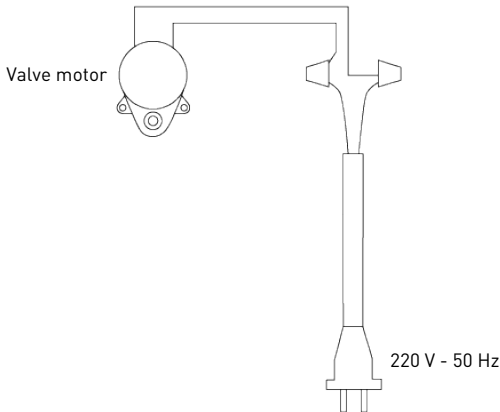

5.10 Bypassing

A bypass valve system should be installed on all water conditioning systems. Bypass valves isolate the softener from the water system and allow unconditioned water to be used. Service or routine maintenance procedures may also require that the system is bypassed.

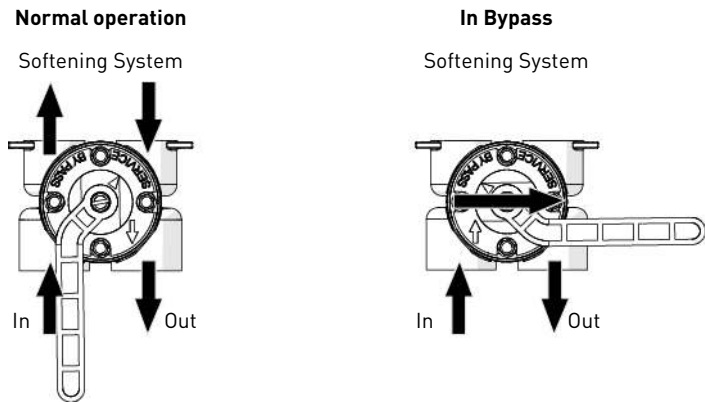

Caution - material



Risk of damage due to bad mounting!

Do not solder pipes with lead-based solder.

Do not use tools to tighten plastic fittings. Over time, stress may break the connections. When the bypass valve is used, only hand tighten the plastic nuts.

Do not use petroleum grease on gaskets when connecting bypass plumbing. Use only 100% silicone grease products when installing any plastic valve. Non-silicone grease may cause plastic components to fail over time.

5.11 Drain line connection

Info



Standard commercial practices are expressed here.

Local codes may require changes to the following suggestions.

Check with local authorities before installing a system.

Mandatory



The drain line must be build with 1/2" semi rigid or rigid piping ! An air gap must be present at the drain!

Caution - material

Risk of damage due to over-force !

The drain line plastic elbow must always be hand-tighten without using the elbow as a lever.

The drain plastic elbow is not designed to support the weight of the tube. The tube has to have its own support.

Do not over tighten the hose tightening ring on its plastic support.

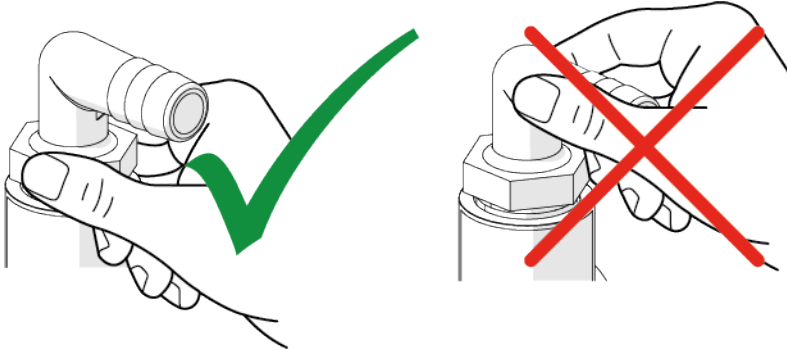

Preferably, the unit should not be more than 6.1 m from the drain. Use an appropriate adapter fitting to connect plastic tubing to the drain line connection of the valve.

If the backwash flow rate exceeds 22.8 lpm or if the unit is located 6.1-12.2 m from the drain, use 19.0 mm (¾") tubing. Use appropriate fittings to connect the 19.0 mm (¾") tubing to the 12.7 mm (½") drain connection on the valve.

The drain line may be elevated up to 1.8 m providing the run does not exceed 4.6 m and water pressure at the softener is not less than 2.76 bar. Elevation can increase by 61 cm for each additional 0.69 bar of water pressure at the drain connector.

Where the drain line is elevated but empties into a drain below the level of the valve, form a 18 cm loop at the far end of the line so that the bottom of the loop is level with the drain line connection. This will provide an adequate siphon trap.

Where the drain empties into an overhead sewer line, a sink-type trap must be used.

Secure the end of the drain line to prevent it from moving.

Mandatory

Waste connections or the drain outlet shall be designed and constructed to provide connection to the sanitary waste system through an air-gap of 2 pipe diameters or 38.1 mm (1½"), whichever is larger.

Caution - material

Risk of damage due to lack of gap !

Never insert the drain line directly into a drain, sewer line or trap. Always allow an air gap between the drain line and the waste water to prevent the possibility of sewage being back-siphoned into the softener.

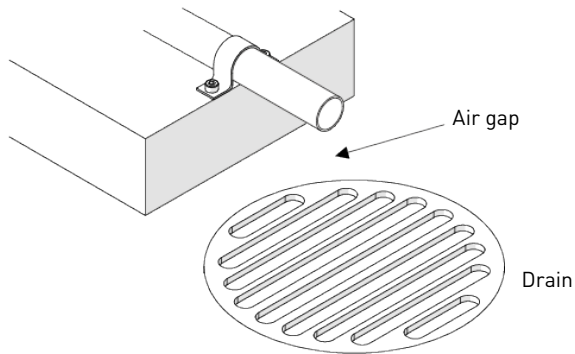

5.12 Overflow line connection

In the event of a malfunction, the brine tank overflow fitting will direct "overflow" to the drain instead of spilling on the floor. This fitting should be on the side of the brine tank. Most brine tank manufacturers feature a pre-drilled hole for the tank overflow connector.

To connect the overflow line, locate the hole on the side of the tank. Insert the overflow fitting into the tank and tighten with plastic thumb nut and gasket as shown below. Attach a 12.7 mm (1/2") I.D. tubing (not supplied) to fitting and run to drain.

Do not elevate overflow higher than overflow fitting.

Do not tie into the drain line of the controller unit. The overflow line must be a direct, separate line from overflow fitting to drain, sewer or tub. Allow an air gap as per drain line instructions.

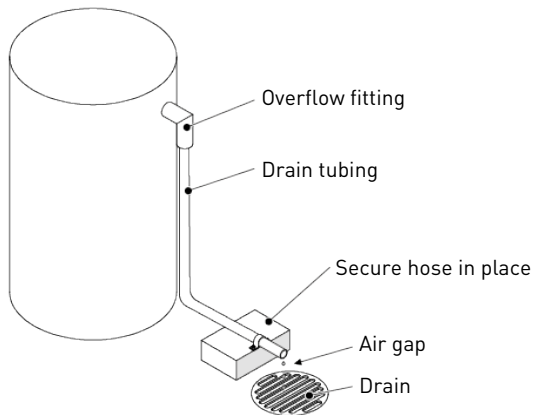

Caution - material



Risk of flooding due to lack of floor drain !

Floor drain is always recommended to avoid flooding in case of overflow.

5.13 Brine line connection

Mandatory



The brine line must be built with 3/8" semi rigid piping !

Caution - material



Risk of malfunction due to the use of wrong equipment !

Flexible and semi-flexible hoses may shrink because of the vacuum during brine draw.

The brine line from the tank connects to the valve. Make the connections and hand tighten. Be sure that the brine line is secure and free from air leaks. Even a small leak may cause the brine line to drain out, and the softener will not draw brine from the tank. This may also introduce air into the valve, causing problems with the valve operation.

Brine line must be equipped with brine tank air check in the brine tank.

6 Programming

6.1 SXT controller

6.1.1 Display

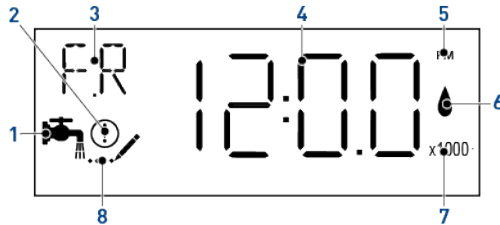

- | | |
|---|---|
| <p>1. Service icon</p> <p>2. Error / Information icon</p> | <ul style="list-style-type: none"> • Appears in service mode; • Flashes if a regeneration cycle has been queued. • Appears in case of error, see Troubleshooting, or in diagnostic mode, see.Diagnostic [->Page 64] |
|---|---|

3. Parameter display

Master programming and diagnostic modes:

- C: Unit capacity;
- CD: Current day;
- CT: Regeneration control type;
- DF: Display format;
- Dn, n=1 to 7: Day of week;
- DO: Days override;
- FM: Flow meter;
- FR: Current flow rate;
- H: Feedwater hardness;
- HR: Hours in service;
- K: Meter pulse;
- NT: Number of tanks;
- PF: Peak flow rate;
- RC: Reserve capacity;
- RF: Regeneration flow;
- RS: Reserve selection;
- RT: Regeneration time;
- SF: Safety factor;
- SV: Software version;
- TD: Time of day;
- TS: Tank in service;
- V: Filter capacity;
- VU: Volume used.

Regeneration cycles:

- B1: First backwash (for dF2b regeneration flow);
- B2: Second backwash (for dF2b regeneration flow);
- BD: Brine draw;
- BF: Brine fill;
- BW: Backwash;
- RR: Rapid rinse.

4. Data display

5. PM indicator

- Appears if controller set in US unit.

6. Flow indicator

- Flashes when outlet flow is detected.

7. x1000 indicator

- Appears when the displayed number is bigger than 9999.

- 8. Programming icon
 - Appears in programming modes.

6.1.2 Commands

Info



Menus are displayed in a defined and incremental order.

If none of the buttons are pushed for 5 minutes in the Programming mode, or if there is a power failure, the controller returns to Service mode without saving.

Mandatory



In order to store the new settings in the programming mode, it is necessary to go through all the parameters !

1. Press to pass to the next step.
2. Use and to adjust the values.

6.1.3 Setting the time of the day (TD)

Set the time in the system.

1. Press and hold or until the programming icon replaces the service icon and the parameter display reads TD.
2. Set the time with or .
3. Press to validate the selection and return to the service mode, or wait for 10 seconds.

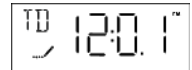

6.1.4 Basic programming

6.1.4.1 Basic programming mode chart

Parameter	Options	Definition	Note	
DO	Days override	0 to 99	Day	-
RT	Regeneration time	00:00:00 to 23:59:59	Hour	Regeneration time will not appear unless regeneration day override is on.
H	Feedwater hardness	1 to 1990	°TH, ppm or grains	Only displayed for volumetric regenerations.
RC	Fixed reserve capacity	0 to 50	%	Only displayed for volumetric regenerations and if set in reserve selection.
SF	Safety factor	0 to 50	%	Only available if set in reserve selection.
CD	Current day	1 to 7	Day of the week	-

6.1.4.2 Day of override (DO)

Set the maximum number of days of operation without regeneration according to local regulation.

1. Press and simultaneously for 5 seconds to enter the menus sequence.
2. Select the number of days of override with and .
3. Press to validate the selection and advance to the next parameter.



6.1.4.3 Regeneration time (RT)

Determine the time of regeneration at a time of low or no water usage.

1. Adjust the regeneration time with and .
2. Press to validate the selection and advance to the next parameter.

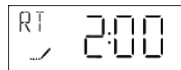

6.1.4.4 Feed water hardness (H)

Set the feed water hardness in °TH.

1. Adjust the feed water hardness with and .
2. Press to validate the selection and advance to the next parameter.

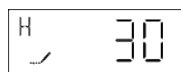

6.1.4.5 Reserve capacity (RC) or (SF)

Determine the reserve capacity in litre or in percentage.

1. Adjust the reserve capacity with and .
2. Press to validate the selection and advance to the next parameter.

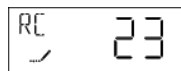

6.1.4.6 Current day of the week (CD)

Determine the day of regeneration.

Info



Appears only if the softener is set to "weekly time clock".

1 for Monday, 2 for Tuesday, 3 for Wednesday, 4 for Thursday, 5 for Friday, 6 for Saturday and 7 for Sunday.

1. Adjust the day of the week with and .
2. Press to validate the selection and exit the basic programming mode.



6.1.5 Master programming mode

Info



As soon as programming mode is entered, all parameters can be displayed or set to suit the needs.

Depending on the current programming, some functions will not be displayed or will not be selectable.

6.1.5.1 Master programming mode chart

Parameter	Options	Definition	Note	
DF	Display format	GAL	US units	-
		Ltr	Metric units	-
RF	Regeneration flow	dF1b	Std DF single backwash	Standard for 9000 Twin valve
		dF2b	Std DF double backwash	-
		FLtr	Filter	To be used with standard piston only.
		UFbd	UF brine first	-
		UFlt	UF filter	To be used with UF piston only.
		Othr	Other	-
CT	Regeneration control type	Fd	Metered delayed	-
		FI	Metered immediate	Standard for 9000 Twin valve
		tc	Time clock	-
		dAY	Day of the week	-
NT	Number of tanks	1	Single tank system	-
		2	Double tanks system	-
TS	Tank in service	U1	Tank 1 in service	Only displayed for double tanks system.
		U2	Tank 2 in service	
C	Unit capacity	0.1 to 9'999	(°TH/°dH).L x1'000	Only displayed for volumetric regenerations with DF set in Ltr.
		1 to 9'999	x1'000 grains	Only displayed for volumetric regenerations with DF set in GAL.
V	Filter capacity	0.1 to 9'999	x1'000 L	Only displayed for filter with DF set in Ltr.
		1 to 9'999	GAL	Only displayed for filter with DF set in GAL.
		1 to 9'999	x1'000 GAL	
H	Feedwater hardness	1 to 1'990	°TH/°dH	Only displayed for volumetric regenerations with DF set in Ltr.
		1 to 199	grains per gallon	Only displayed for volumetric regenerations with DF set in GAL.
RS	Reserve selection	SF	Safety factor	-
		rc	Fixed reserve capacity	-
SF	Safety factor	0 to 50	%	Only available if set in reserve selection.

Parameter		Options	Definition	Note
RC	Fixed reserve capacity	0 to 50	%	Only displayed for volumetric regenerations and if set in reserve selection.
DO	Days override	0 to 99	Day	-
RT	Regeneration time	00:00:00 to 23:59:59	Hour	Regeneration time will not appear unless regeneration day override is on.
B1	First backwash	0 to 199	Minute	Only displayed for dF2b regeneration flow. In case of dF1b regeneration flow, the screen shows BW.
BD	Brine draw			BD consist of time for brine draw and slow rinse.
B2	Second backwash			Only shown in dF2b regeneration flow.
RR	Rapid rinse			-
BF	Brine fill	0 to 199	Minute	-
BW	Backwash			-
Rn	Cycle number n=1 to 6			Only if "Othr" is chosen under VT . R1, R2, R3, etc... will be displayed instead.
Dn	Day of week, n=1 to 7	ON - OFF	-	Regeneration setting for each day of the week. OFF by default. Not available for 9000 serie valves.
CD	Current day	1 to 7	Day of the week	Not available for 9000 serie valves
FM	Flow meter type	P0.7	¾" paddle wheel	-
		t0.7	¾" turbine	-
		P1.0	1" paddle wheel	-
		t1.0	1" turbine	-
		P1.5	1½" paddle wheel	-
		t1.5	1½" turbine	-
		P2.0	2" paddle wheel	-
		Gen	Generic or non-Fleck	-
K	Meter pulse	0.1 to 999.9	Litre	Only displayed for generic flow meter type.

6.1.5.2 Entering master programming mode

1. Press and hold ▼ or ▲ until the programming icon replaces the service icon and the parameter display reads TD.
2. Set the time to 12:01 PM with ▼ or ▲.
3. Press ↻ to validate the selection and return to the service mode, or wait for 10 seconds.
4. Press and hold ▼ and ▲ until the programming icon replaces the service icon and the display format screen appears.

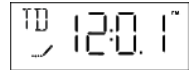

6.1.5.3 Display format mode (DF)

Select the unit of measure.

Options:

- GAL: U.S. gallons and 12-Hour AM/PM;
- Ltr: litres and 24-Hour.

1. Press ▼ or ▲ to select the unit.
2. Press ↻ to validate the selection and move to the next parameter.

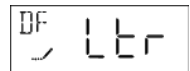

6.1.5.4 Regeneration flow (RF)

Select the regeneration flow.

Options:

- dF1b: standard downflow single backwash (standard);
- Othr: other;
- UFtr: upflow filter (for 5000 filter);
- UFbd: upflow brine first;
- FLtr: filter, to be used with standard piston only (except 5000);
- dF2b: standard downflow double backwash.

1. Press ▼ or ▲ to select the regeneration flow.
2. Press ↻ to validate the selection and move to the next parameter.

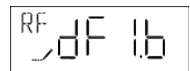

6.1.5.5 Regeneration control type (CT)

Select the regeneration controller type.

Options:

- Fd: meter delayed;
- Fl: meter immediate;
- tc: time clock;
- dAY: day of the week.

1. Press or to select the regeneration control type.
2. Press to validate the selection and move to the next parameter.



6.1.5.6 Number of tanks (NT)

Select the number of tanks.

Options:

- NT 1: single tank system;
- NT 2: double tanks system.

Mandatory



Due to the 4600 valve being designed for single tank system only, set valve type to 1.

1. Press or until "---1" is displayed.
2. Press to validate the selection and move to the next parameter.

6.1.5.7 Tank in service (TS)

Info



This parameter appears only if number of tanks (NT) is set to 2.

If it appears, the 4600 valve being a single tank system, go back to number of tanks (NT) and set it to 1.

6.1.5.8 Unit capacity (C)

Set the unit capacity.

Mandatory



Enter the capacity of the media bed in m³ x °TH or g as CaCO₃ for softener system (C is displayed in the upper left corner) or in litres for filter (V is displayed in the upper left corner) !

Info



The unit capacity parameter is only available if the controller type has been programmed for volumetric regeneration.

The unit capacity can be set from 0.1 to 9'999 x1'000 °TH.L if **DF** = Ltr or from 1 to 9'999 x1'000 grains if **DF** = GAL.

1. Press or to select the unit capacity.
2. Press to validate the selection and to move the next parameter.

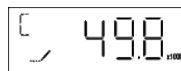

6.1.5.9 Filter capacity (V)

Set the filter capacity.

Info



The filter capacity parameter is only available if the regeneration flow has been programmed for filter.

The filter capacity can be set from 0.1 to 9'999 x1'000 Ltr if **DF** = Ltr or from 1 to 9'999 -> 1 to 9'999 x1'000 grains if **DF** = GAL.

1. Press or to select the filter capacity.
2. Press to validate the selection and to move the next parameter.

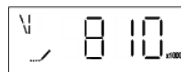

6.1.5.10 Feedwater hardness (H)

Set the feedwater hardness.

Mandatory



Enter the feedwater hardness in °TH, ppm or grains of hardness for softener system !

Info



The feedwater hardness parameter is only available if the controller type has been programmed for volumetric regeneration.

The feedwater hardness can be set from 1 to 1'990 °TH/dH if **DF** = Ltr, or 1 to 199 in grains per gallon if **DF**=GAL.

1. Press or to set the feedwater hardness in accordance with display format (DF), see Display format mode (DF) [->Page 59].
2. Press to validate the selection and to move the next parameter.

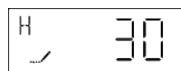

6.1.5.11 Reserve selection (RS)

Info



This parameter is not useful when regeneration control type (CT) is set to FI.

Set the reserve type.

Options:

- SF: safety factor;
- rc: fixed reserve capacity.

1. Press or to set the reserve type.
2. Press to validate the selection and move to the next parameter.

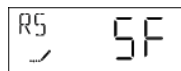



6.1.5.11.1 Safety factor (SF)

Info



This parameter is not shown if RS is set to RC.

The safety factor can be set from 0 to 50% of the initial volumetric capacity.

1. Press  or  to set the reserve type.
2. Press  to validate the selection and move to the next parameter.

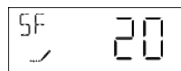



6.1.5.11.2 Reserve capacity (RC)

Info



This parameter is not shown if RS is set to SF.

The fixed reserve capacity can be set up to a volume equivalent to 50% of the initial volumetric capacity.

1. Press  or  to set the reserve type.
2. Press  to validate the selection and move to the next parameter.

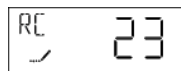

6.1.5.12 Days override (DO)

Set the maximum number of days between regeneration cycles.

Info



This parameter allows setting the maximum amount of days that the system can stay in service mode without regeneration.



Mandatory



In time clock mode, this parameter must be set and the controller will need at least one regeneration day activated.

Setting the parameter to "OFF" disables this function.

The number of days can be set from OFF, or 1 to 99 days.

1. Press  or  to set the days override.
2. Press  to validate the selection and move to the next parameter.



6.1.5.13 Regeneration time (RT)

Set the regeneration time.

Info



Regeneration time is the time of the day when regenerations occur for delayed regeneration of any type and calendar override regeneration.

1. Press or to set the regeneration time.
2. Press to validate the selection and move to the next parameter.

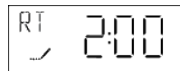

6.1.5.14 Regeneration cycle step duration

Set the duration in minutes of each regeneration cycle.

Info



Setting a cycle step to 0 will cause the controller to skip that step during regeneration, but keeps the following steps available.

The different regeneration cycles are listed in sequence based on the regeneration flow selected for the system.

All cycles can be set from 0 to 199 minutes.

6.1.5.14.1 Regeneration abbreviations

B1	First backwash	BF	Brine fill
B2	Second backwash	BW	Backwash
BD	Brine draw	RR	Rapid rinse

6.1.5.15 Day of week (Dn, n = 1 to 7)

Set the day of week for regeneration.

Info



The day of week parameter is only available if "day" mode has been set in controller type selection.

1. Press or to set "ON" or "OFF" to set the day as a regeneration day.
2. Press to validate the selection.
3. Repeat the two previous steps until **D7** is set.
4. Press to validate the selection and move to the next parameter.

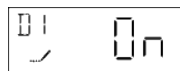

6.1.5.16 Current day (CD)

Set the current day.

Info



The current day is defined from D1 (Monday) to D7 (Sunday).

1. Press or to set the current day.
2. Press to validate the selection and move to the next parameter.





6.1.5.17 Flow meter type (FM)

Select the flow meter type.

Options:

- P0.7: ¾" paddle wheel meter (Standard setting for 4600, 5600 and 9100);
- t0.7: ¾" turbine meter;
- P1.0: 1" paddle wheel meter (Standard setting for 2750 and 9000);
- t1.0: 1" turbine meter;
- P1.5: 1½" paddle wheel meter (Standard setting for 2850);
- t1.5: 1½" turbine meter;
- P2.0: 2" paddle wheel meter;
- Gen: generic or other non-Fleck meter.

1. Press  or  to set the flow meter type.
2. Press  to validate the selection and move to the next parameter or exit master programming mode and save modifications done.



6.1.5.18 Meter pulse (K)

Set the meter pulse for a non-standard flow meter.

Info



The meter pulse parameter is only available if the Gen option has been set in flow meter type selection.

1. Press  or  to set the meter constant in pulses per unit of volume.
2. Press  to validate the selection and to exit the master programming mode.

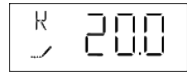

6.1.6 Filter programming

To use the valve as a filter, in the master programming mode, set the regeneration flow (VT) to filter (FLtr). The controller will let set only the steps necessary to the filter mode, which are: regeneration control type (CT), days override (DO), regeneration time (RT), backwash (BW), rapid rinse (RR), day of week (Dn) and current day (CD).





6.1.7 Diagnostic

Info



Depending on current settings, some displays cannot be viewed.
If none of the buttons are pushed for 1 minute in the diagnostic mode the controller returns to Service mode.

6.1.7.1 Commands

1. Press and hold  and  for five seconds to enter the diagnostic mode.
2. Press  or  to navigate in the diagnostic mode.
3. Press  to exit the Diagnostic mode at any time.

6.1.7.2 Current flow rate (FR)

Info



The display is updated every second.

1. Current flow rate display (L/min or gpm depending on display format programmed):

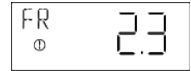

6.1.7.3 Peak flow rate (PF)

Info



The controller registers the highest flow rate (L/min) since the last regeneration.

1. Peak flow rate display:

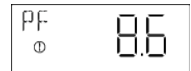

6.1.7.4 Hours since last regeneration (HR)

Info



Shows the number of hours since the last regeneration, indicating the length of the current service cycle.

1. Hours since last regeneration display:



6.1.7.5 Volume since last regeneration (VU)

Info



Shows the volume used since the last regeneration (L).

1. Volume since last regeneration display (L or Gal depending on display format programmed):

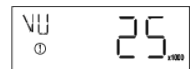

6.1.7.6 Reserve capacity (RC)

Info



Shows the remaining reserve volume until next regeneration (L).

1. Volume until next regeneration display (L or Gal depending on display format programmed):

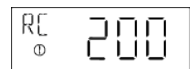

6.1.7.7 Software version (SV)

Info



Shows the version of the software used by the controller.

1. Software version display:



6.1.8 Resetting the controller

Mandatory



Once you have completed this operation, check all programming steps !

Info



There are two options to reset: partial and hard reset.

Partial reset will set all the parameters to default values, except volume remaining in volumetric systems and days since last regeneration in time clock systems.

Hard reset will set all the parameters to default values.

6.1.8.1 Soft reset (SR)

1. Press and hold and for 25 seconds while in normal service mode until **SR** is displayed.
2. Reprogram all parameters in Master programming mode.

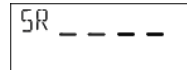

6.1.8.2 Hard reset (HR)

1. Hold while powering up the unit.
2. The display shows **HR**.
3. Reprogram all parameters in Master programming mode.

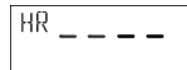

6.2 MECH controller

6.2.1 Time of day

1. Press the clutch [1].
2. Turn the hour wheel [2] to display the correct hour in the window [3].

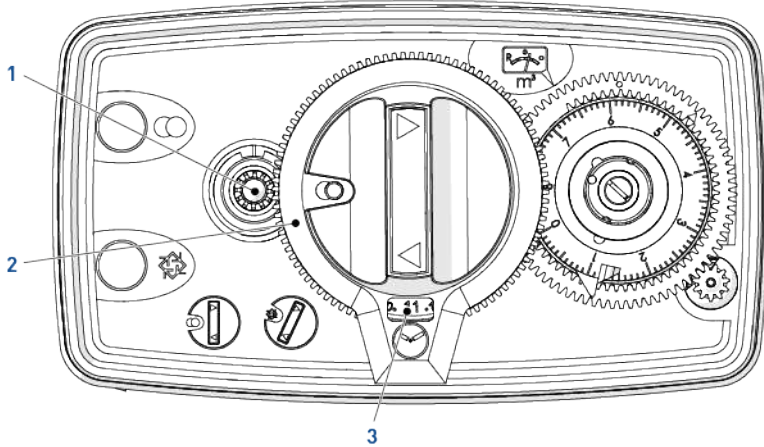

6.2.2 Volumetric

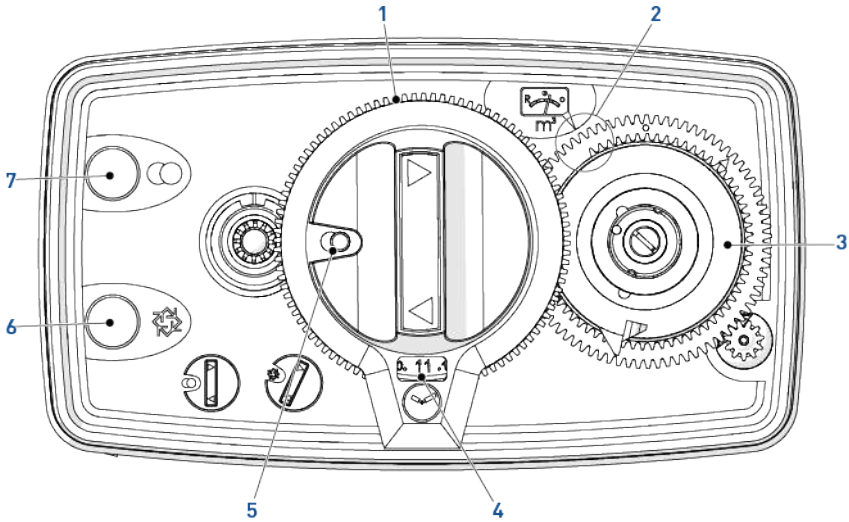

- | | |
|---|---|
| <p>1. 24 hours wheel</p> <p>2. Available capacity</p> <p>3. Program wheel</p> <p>4. Time of day</p> <p>5. Service position</p> | <ul style="list-style-type: none"> • Shows the system remaining capacity. • Defines the system capacity in m³. • Shows the current time. • Service; • Regeneration; • Backwash; • Brine draw/slow rinse; • Brine refill. |
| <p>6. Red lamp</p> <p>7. Green lamp</p> | <ul style="list-style-type: none"> • Lights when the valve regenerate. • Lights when in service. |

6.2.2.1 Calculating the system capacity

Set the capacity of soft water between two regenerations using the following formula:

$$\text{Water capacity [m}^3\text{]} = (\text{Exchange capacity [m}^3\text{°tH]} - \text{Reserve capacity [m}^3\text{)}) / \text{Water hardness [°tH]}$$

6.2.2.2 Set the system capacity

1. Lift the transparent disc (1) and display the capacity facing the white dot (2).

Info



Example for the following drawing, the capacity set is 5.8 m³ between two regenerations.

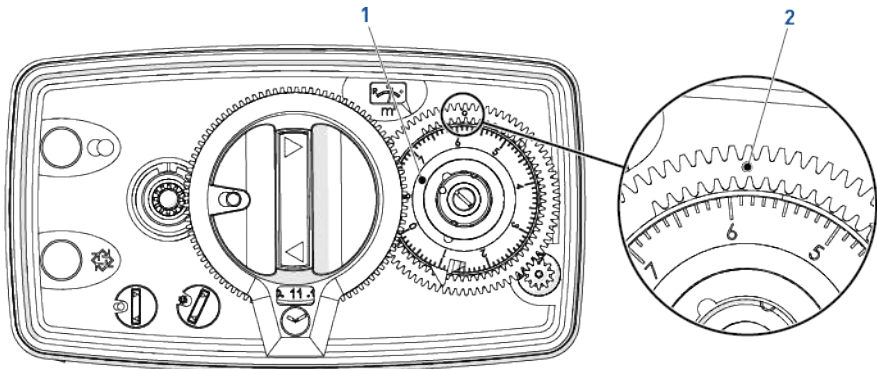

6.2.3 Time clock

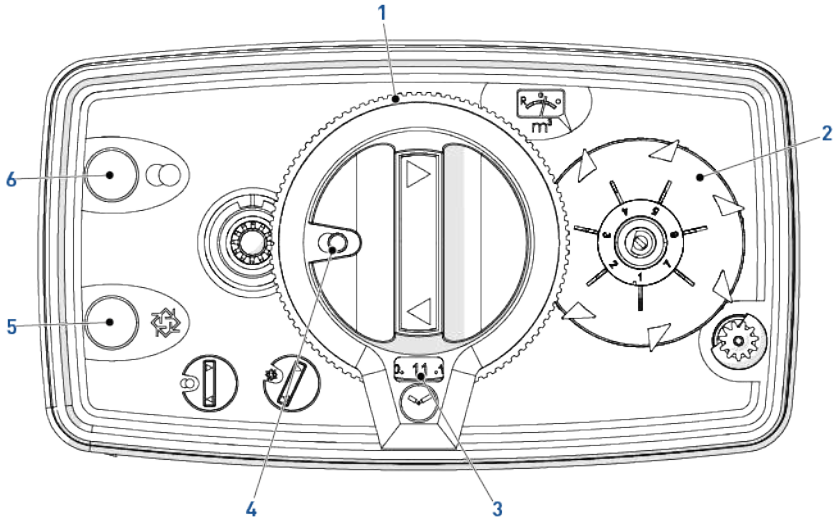

- | | |
|---|---|
| <p>1. 24 hours wheel</p> <p>2. Program wheel</p> <p>3. Time of day</p> <p>4. Service position</p> | <ul style="list-style-type: none"> • Defines the number of days between two regenerations. • Shows the current time. • Service; • Regeneration; • Backwash; • Brine draw/slow rinse; • Brine refill. |
| <p>5. Red lamp</p> <p>6. Green lamp</p> | <ul style="list-style-type: none"> • Lights when the valve regenerate. • Lights when in service. |

6.2.3.1 Calculating the number of days between two regenerations

Set the number of days between two regenerations using the following formulas:

Water capacity [m³] = [Exchange capacity [m³°tH] - Reserve capacity [m³]] / Water hardness [°tH]

Number of days between regenerations = Water capacity [m³] / Daily water consumption [m³]

6.2.3.2 Set the number of days between two regenerations

1. Push the pins (1) out to set up.

Info



Example for the following drawing, the regeneration will occurs on Monday and Thursday.

There are two time clock wheels:

7 days: based on the week, number 1 will refer to Monday, number 7 to Sunday;

12 days: allows to set a regular interval every 2, 3, 4 or 6 days.

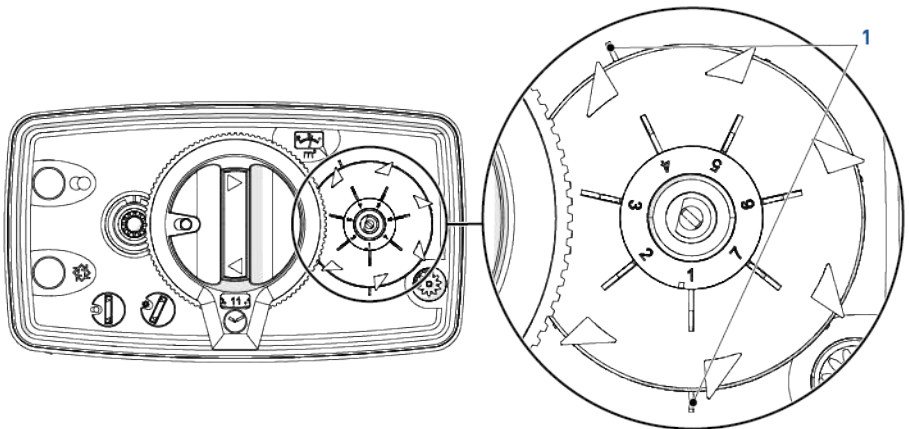

6.2.4 Salt volume per regeneration

6.2.4.1 Salt volume definition

Set the weight of salt to be used during regeneration using the following table and formula.

Salt weight [g/L _{resin}]	Exchange capacity [°tH/m ³ /L _{resin}]	Salt weight [g/°tH/m ³]
80	4	20
125	5	25
180	6	30

Weight of salt to be set = Volume of resin [L] x Salt weight [g/L_{resin}]

Example

16 liters of resin x 125 g = 2000 g (2 kg of salt).

6.2.4.2 Set the salt volume per regeneration

1. Calculate the weight of salt needed per regeneration, see Salt volume definition [→Page 72].
2. Remove the screws **(2)** and the cover **(1)**.
3. Loosen **(5)**.
4. Adjust the segment of the brine cam **(4)** on the sticker **(3)** to the value calculated at the first point of the procedure.
5. Tighten **(5)**.
6. Replace the screws **(2)** and the cover **(1)**.

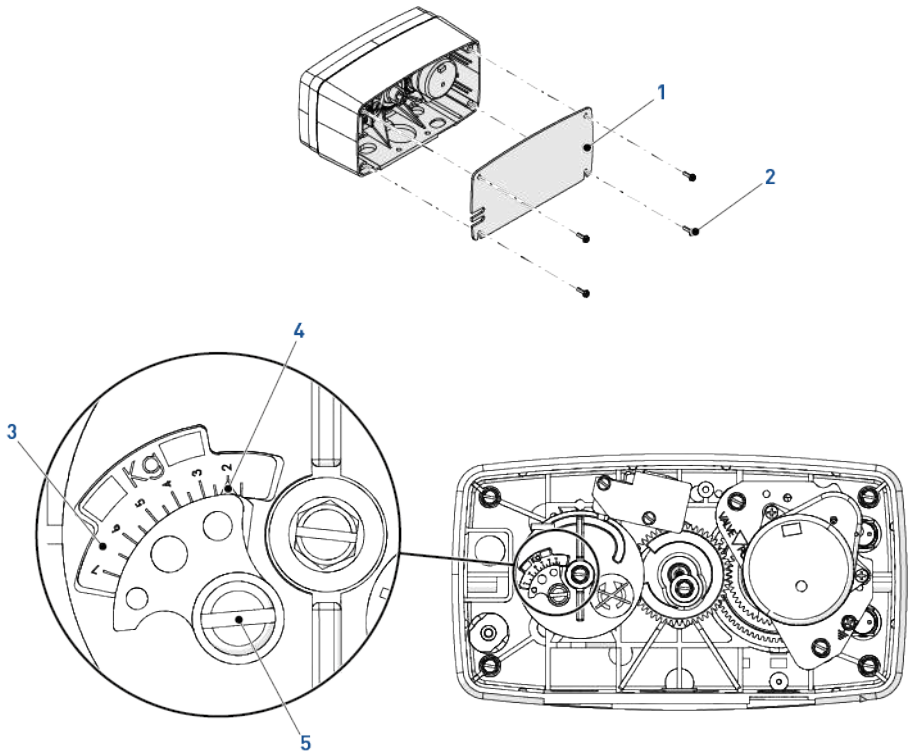

7 Commissioning

Info



This chapter is available for standard regeneration flows. Contact your supplier if the actual regeneration is not standard and if you need assistance.

7.1 Water filling, draining and waterproofness inspection

7.1.1 SXT controller

1. With the bypass still in bypass position (inlet and outlet of the valve closed), plug in the SXT - MECH controller to the power source.
2. Proceed to programming according to your system specification if not done yet.
3. Start a manual regeneration by pressing the regen button for 5 seconds. The piston will move into backwash position. If the first cycle is not backwash, quick cycle the valve until the piston is in backwash position. Once in this position, unplug the SXT - MECH controller from the power source.
4. With the bypass still in bypass position, open the nearest faucet close to the system.
5. Put the bypass slowly in service position. The valve and tank will slowly get filled with raw water, allowing air to be purged by the drain and/or by the open faucet next to the system. Open the inlet progressively until fully open position.
6. Once the drain runs clear and the bypass valve is fully in service position, plug in again the SXT - MECH controller to the power source.
7. Push on the regen button once to move the piston to the next regeneration cycle position. Leave the valve 1 minute in each position and move to the next one, until refill cycle is displayed. When refill cycle is displayed, let the valve run the entire cycle and check the level of water in the brine tank or cabinet. The level of water in the brine tank should be about 5 cm above the salt platform. You may want to mark the level on the brine tank as this can be used as an indicator for the future lifetime of the softener.
8. Once refill cycle is completed, the valve will automatically go back into service position (unless non-standard regen sequence is programmed). Start again a manual regeneration by pressing for 5 seconds on the regen button. The valve will move to backwash position.
9. Press the regen button once to move to brine draw position. Check to see in the brine tank if the water level decreases.
10. Once the draw function is observed and confirmed (level of water in the brine tank or cabinet has decreased), you may go through each cycle pushing on the regen button until refill cycle, leave the water come back to the "full" level, and then push on the regen button so that the valve returns into service position.
11. Fill the brine tank or cabinet with salt. You may want to mark the level of water in the brine tank/cabinet when completely refilled with water and full of salt. In the future, after each regeneration, you can visually control that the quantity of water refilled should be between the 2 marks done. Marking are optional, but may allow to visually detecting any irregularity during regeneration that may lead to softener inefficiency.
12. With the brine tank completely refilled and full of salt, adjust the safety brine valve in the brine well. Make sure the overflow elbow is installed above the float level.

13. After the softener has been running a few minutes in service, proceed to hardness test on outlet water to make sure the water is treated as per requirements.

The system is ready and in service.

7.1.2 MECH controller

1. With the bypass still in Bypass position (inlet and outlet of the valve closed), proceed to programming according to your system specification if not done yet.
2. Turn ON the main water supply.
3. Open a cold water faucet nearby and let run a few minutes or until the system is free from foreign material (usually solder) that may have resulted from the installation.
4. Once the faucet runs clear, put the bypass slowly in service position.
5. The valve and tank will slowly get filled with raw water, allowing air to be purged by the drain and/or by the open faucet next to the system. Open the inlet progressively until fully open position. Let run until the air is purged from the unit.
6. Close the water faucet nearby.
7. Plug the valve to a power source. Check that the valve is in service position.
8. Fill approximately 25mm of water above the grid plate, (if used). Otherwise, fill to the top of the air check in the brine tank. Do not add salt to the brine tank at this time.
9. Initiate a manual regeneration, bring the valve into "brine draw and slow rinse position" in order to draw water from the brine tank until the blockage of the air check; the water level will be approximatively in the middle of the air check.
10. Open a cold water faucet and let the water run in order to drain the air out of the circuit.
11. Bring the valve in brine refill position and let it get back to service position automatically.
12. Close the cold water faucet.
13. Fill the brine tank or cabinet with salt. You may want to mark the level of water in the brine tank/cabinet when completely refilled with water and full of salt. In the future, after each regeneration, you can visually control that the quantity of water refilled should be between the two marks done. Marking are optional, but may allow to visually detect any irregularity during regeneration that may lead to softener inefficiency.
14. With the brine tank completely refilled and full of salt, adjust the safety brine valve in the brine well. Make sure the overflow elbow is installed above the float level.
15. After the softener has been running a few minutes in service, proceed to hardness test on outlet water to make sure the water is treated as per requirements.

The system is ready and in service.

7.2 Sanitization

7.2.1 Disinfection of water softeners

The materials of construction of the modern water softener will not support bacterial growth, nor will these materials contaminate a water supply. In addition, during normal use, a softener may become polluted with organic matter, or in some cases with bacteria from the water supply. This may result in an off-taste or odour in the water.

Thus, the softener may need to be disinfected after installation. Some softeners will require periodic disinfection during their normal lifetime. Consult the installing dealer for more information on softener disinfection.

Depending on the conditions of use, the softener type, the type of ion exchanger and the disinfectant available, a choice can be made among the following methods.

7.2.2 Sodium or calcium hypochlorite

These materials are satisfactory for use with polystyrene resins, synthetic gel zeolite, greensand and bentonites.

5.25% Sodium hypochlorite

If stronger solutions are used, such as those sold for commercial laundries, adjust the dosage accordingly.

Dosage

Polystyrene resin: set 1.25 mL fluid per 1 L of resin.

Non-resinous exchangers: set 0.85 mL fluid per 1 L.

Brine tank softeners

Backwash the softener and add the required amount of hypochlorite solution to the well of the brine tank. The brine tank should have water in it to permit the solution to be carried into the softener.

Proceed with the normal regeneration.

Calcium hypochlorite

Calcium hypochlorite, 70% available chlorine, is available in several forms including tablets and granules. These solid materials may be used directly without dissolving before use.

Do not let the disinfectant stand for more than 3 hours in the brine tank before the regeneration start.

Dosage

Measure two grains ~ 0.11 mL for 1 L.

Brine tank softeners

Backwash the softener and add the required amount of hypochlorite to the well of the brine tank. The brine tank should have water in it to permit the chlorine solution to be carried into the softener.

Proceed with the normal regeneration.

7.2.3 Electro chlorination (if present)

Valves or systems already equipped with an electrochlorinator device or system will be sanitized during the brine draw phase.

8 Operation

8.1 SXT controller

8.1.1 Display

8.1.1.1 Display during operation

Examples:

- Valve in service with day time:
- Valve in service with volume remaining before regeneration:
- Remaining days before next regeneration:
- In volumetric regeneration flow, reserve 1223 litres remaining:
- In volumetric regeneration flow, exhausted reserve, immediate or delayed start in regeneration depending on the adjustment:

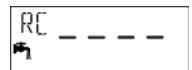
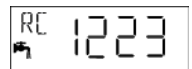
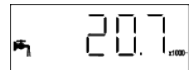
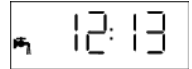

Info



In delayed volumetric mode, the icon  flashes as soon as the reserve begins to be used.

8.1.1.2 Display during regeneration

During a regeneration the display shows the current cycle step and the time remaining for that cycle. The countdown for the time remaining starts only when the valve is in the cycle displayed.

Examples:

- Valve going to rapid rinse. **RR** are flashing:
- Refill cycle, 12 min 38 sec. left:
- Rapid rinse cycle, 2 min 17 sec. left:

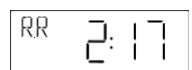
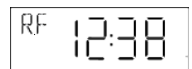
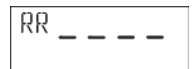

8.1.2 Recommendations

- Use only regeneration salts designed for water softening in accordance with EN973;
- for optimal system operation, the use of clean salt, free from impurities, is recommended (for example salt pellets);
- do not use ice melt, block, or rock salts;
- the sanitizing process (both with liquid and electrochlorination) may introduce chlorine compounds which may reduce the lifetime of the ion exchange resins. Refer to the technical guides for resins in common use, providing necessary checks on the system.

8.1.3 Manual regeneration

Mandatory



The controller must be in service in order to enable this procedure !

8.1.3.1 Manual delayed regeneration

1. Press  once for delayed regeneration.
 - ⇒ The regeneration starts at the programmed regeneration time. See chapter Regeneration time (RT) [→Page 62].
 - ⇒ The service icon flashes.

Info



To cancel: press  again.

The service icon stops flashing.

8.1.3.2 Immediate regeneration

1. Press and hold  for 5 seconds to initiate immediate manual regeneration regardless from the programmed regeneration control type.

8.1.3.3 To advance regeneration cycles

1. Press  to pass to the next regeneration cycle.

8.1.4 Operation during a power failure

- Current valve position, cycle step time elapsed, and time of day is stored 24 hours during a power failure, and will be restored upon power restoration;
- in regeneration, when power is shutting down, the controller saves the current regeneration data. When power is restored, the controller resumes the regeneration cycle at the point where power failed;

Caution - material



Risk of damage due to power failure !

Without power, the valve stays in its current position until power is restored.

The system should include all required safety components to prevent overflows resulting from a power failure during regeneration.

-
- all the program settings are stored in a permanent memory;
 - time is kept during a power failure and the time of day is adjusted upon restoration of the power (as long as the power is restored within 24 hours);
 - the time of day on the main display screen will flash when there has been a power failure;
 - the flashing of the time of day can be stopped by pressing any button on the display.

8.2 MECH controller

8.2.1 Display during operation

8.2.1.1 During service

- Valve in service:

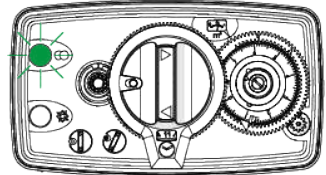

8.2.1.2 During regeneration

During regeneration the display shows the current cycle step:

- Backwash:

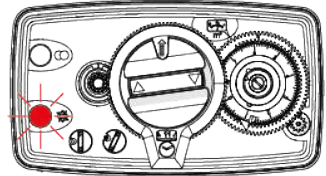

- Brine draw & slow rinse:

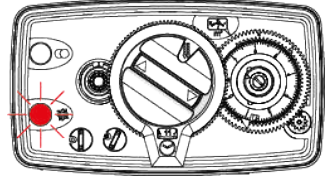

- Brine refill:

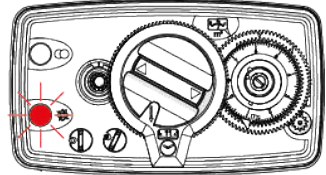

8.2.2 Recommendations

- Use only regeneration salts designed for water softening upon regulation EN973;
- for optimal system operation, the use of clean salt and impurities free is recommended (for example salt pellets);
- the sanitizing process (both with liquid and electrochlorination) may introduce chlorine compounds which may reduce the lifetime of the ion exchange resins. Refer to the technical guides for resins in common use, providing necessary checks on the system.

8.2.3 Manual regeneration

Mandatory



The controller must be in service in order to enable this procedure !

8.2.3.1 Manual immediate regeneration

1. Turn the control knob (3) until  appears in the window (2) and the red light (1) lights.

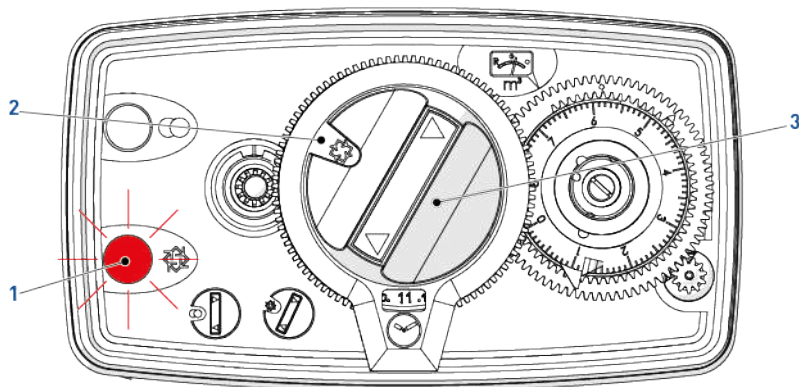

8.2.3.2 To advance regeneration cycles

1. Turn the control knob (3) until the desired cycle appears in the window (2).

8.2.4 Operation during power failure

The valve stops in its actual position during power failure.

9 Maintenance

Mandatory



Cleaning, maintenance and service operation shall take place at regular intervals and must be done by qualified personnel only in order to guarantee the proper functioning of the complete system.

Report maintenance done in the Maintenance chapter of the User Guide document.

Failure in respecting above instructions may void the warranty!

9.1 General system inspection

Mandatory



Must be done, at minimum, once a year !

9.1.1 Water quality

9.1.1.1 Valve used for softening

1. Raw water total hardness.
2. Treated water hardness.

9.1.1.2 Valve used for filtration

1. Check for raw water analysis and filter's targeted contaminants concentration.
2. Check for treated water analysis and compare with raw water data.

9.1.2 Mechanical Checks

1. Inspect general condition of softener/filter and associated ancillaries and check for any leaks, ensure valve connection to piping is made with adequate flexibility as per manufacturer instruction.
2. Inspection of electrical connections, verify wiring connections and search for evidence of overloading.
3. Verify settings of electronic timer, verify regeneration frequency, and make sure the valve configuration is appropriate for media and tank size.
4. Check water meter, if present, report water meter settings and compare with previous inspection.
5. If water meter is present, verify total water consumption compared to previous visit.
6. If pressure gauges are installed before and after softening/filtering system, verify and record static and dynamic pressure, reporting pressure drop. Verify that inlet pressure respects valve and softening/filtering system limits. Verify that pressure drop stay stable year on year, adapt backwash duration if required.
7. If pressure gauges are not present, but suitable points exist, install temporary pressure gauge(s) to perform precedent point.

9.1.3 Regeneration test

9.1.3.1 Valve used for softening

1. Check condition of brine tank and any associated equipment.
2. Check salt level in brine tank.
3. Initiate regeneration test.
 - ⇒ Check brine draw during brine draw stage.
 - ⇒ Check brine tank refill.
 - ⇒ Check operation of safety brine valve, where fitted.
 - ⇒ Check for brine draw off levels.
 - ⇒ Check for resin loss at the drain during regeneration.
 - ⇒ Where fitted, check for satisfactory operation of solenoid, i.e. outlet shut off during regeneration and/or brine line shut off valve(s).
4. Test and record Total Hardness of outlet water from softener vessel(s).

9.1.3.2 Valve used for filtration

1. Initiate manual regeneration and observe flow to drain.
2. Make sure flow rate correspond to DLFC configuration.
3. Check for media loss at the drain during backwash.
4. Check to see if water runs clear at the end of the backwash cycle.
5. Observe flow fast rinse cycle and measure pressure drop through the filter system. Pressure drop after fast rinse should return equal or very close to pressure drop recorded after system start-up.
6. Where fitted, check for satisfactory operation of solenoid valve(s) i.e. outlet shut off during regeneration.

9.2 Recommended maintenance plan

9.2.1 Valve used for softening

9.2.1.1 SXT controller

Items	1 year	2 year	3 year	4 year	5 year
Injector & filter	Clean	Clean	Clean	Clean	Clean/ replace if necessary
BLFC***	Clean	Clean	Clean	Clean	Clean/ replace if necessary
DLFC***	Clean	Clean	Clean	Clean	Clean/ replace if necessary
Bypass (if present, contains Orings***)	Clean	Clean	Clean	Clean	Clean/replace if necessary

Items	1 year	2 year	3 year	4 year	5 year
Piston*	Check/clean/ replace if necessary	Check/clean/ replace if necessary	Replace	Check/clean/ replace if necessary	Check/clean/ replace if necessary
Seals & spacers*	Check/clean/ replace if necessary	Check/clean/ replace if necessary	Replace	Check/clean/ replace if necessary	Check/clean/ replace if necessary
Brine valve	Check/clean/ replace if necessary	Check/clean/ replace if necessary	Check/clean/ replace if necessary	Check/clean/ replace if necessary	Replace
O-rings***	Check for watertightness /clean or replace in case of leakage	Check for watertightness /clean or replace in case of leakage	Check for watertightness /clean or replace in case of leakage	Check for watertightness /clean or replace in case of leakage	Check for watertightness /clean or replace in case of leakage
Motors	Check	Check	Check	Check	Replace
Gearing	Check	Check	Check	Check	Check/ replace if necessary
Inlet hardness	Check	Check	Check	Check	Check
Residual hardness	Check/adapt mixing screw if necessary	Check/adapt mixing screw if necessary	Check/adapt mixing screw if necessary	Check/adapt mixing screw if necessary	Check/adapt mixing screw if necessary
Electronic/ settings**	Check	Check	Check	Check	Check/ replace if necessary
Transformer**	Check	Check	Check	Check	Check/ replace if necessary
Microswitches	Check	Check	Check	Check	Replace
Meter(s)* (if present)	Check and Clean	Check and Clean	Check and Clean	Check and Clean	Replace
Meter cable(s)* (if present)	Check	Check	Check	Check	Replace
Valve watertightness	Check	Check	Check	Check	Check
Valve to piping watertightness	Check	Check	Check	Check	Check

* Wear parts - durability strongly affected by raw water quality and regeneration frequency.

** Electronic parts – durability strongly affected by power source quality and stability.

*** Elastomer durability is strongly affected by raw water concentration in chlorine and its derivative.

9.2.1.2 MECH controller

Items	1 year	2 year	3 year	4 year	5 year
Injector & filter	Clean	Clean	Clean	Clean	Clean/ replace if necessary
BLFC***	Clean	Clean	Clean	Clean	Clean/ replace if necessary
DLFC***	Clean	Clean	Clean	Clean	Clean/ replace if necessary
Bypass (if present, contains Orings***)	Clean	Clean	Clean	Clean	Clean/replace if necessary
Piston*	Check/clean/replace if necessary	Replace	Check/clean/replace if necessary	Replace	Check/clean/replace if necessary
Seals & spacers*	Check/clean/replace if necessary	Replace	Check/clean/replace if necessary	Replace	Check/clean/replace if necessary
Brine valve	Check/clean/replace if necessary	Check/clean/replace if necessary	Check/clean/replace if necessary	Check/clean/replace if necessary	Replace
O-rings***	Check for watertightness /clean or replace in case of leakage	Check for watertightness /clean or replace in case of leakage	Check for watertightness /clean or replace in case of leakage	Check for watertightness /clean or replace in case of leakage	Check for watertightness /clean or replace in case of leakage
Motors	Check	Check	Check	Check	Replace
Gearing	Check	Check	Check	Check	Check/ replace if necessary
Inlet hardness	Check	Check	Check	Check	Check
Residual hardness	Check/adapt mixing screw if necessary	Check/adapt mixing screw if necessary	Check/adapt mixing screw if necessary	Check/adapt mixing screw if necessary	Check/adapt mixing screw if necessary
Settings	Check	Check	Check	Check	Check
Transformer**	Check	Check	Check	Check	Check/ replace if necessary
Microswitches	Check	Check	Check	Check	Replace
Meter(s)* (if present)	Check and Clean	Check and Clean	Check and Clean	Check and Clean	Replace
Meter cable(s)* (if present)	Check	Check	Check	Check	Replace
Valve watertightness	Check	Check	Check	Check	Check

Items	1 year	2 year	3 year	4 year	5 year
Valve to piping watertightness	Check	Check	Check	Check	Check

* Wear parts - durability strongly affected by raw water quality and regeneration frequency.

** Electronic parts – durability strongly affected by power source quality and stability.

*** Elastomer durability is strongly affected by raw water concentration in chlorine and its derivative.

9.2.2 Valve used for filtration

9.2.2.1 SXT controller

Items	1 year	2 year	3 year	4 year	5 year
DLFC***	Clean	Clean	Clean	Clean	Clean/ replace if necessary
Bypass (if present, contains Orings***)	Clean	Clean	Clean	Clean	Clean/replace if necessary
Piston*	Check/clean/replace if necessary	Check/clean/replace if necessary	Replace	Check/clean/replace if necessary	Check/clean/replace if necessary
Seals & spacers*	Check/clean/replace if necessary	Check/clean/replace if necessary	Replace	Check/clean/replace if necessary	Check/clean/replace if necessary
O-rings***	Check for watertightness /clean or replace in case of leakage	Check for watertightness /clean or replace in case of leakage	Check for watertightness /clean or replace in case of leakage	Check for watertightness /clean or replace in case of leakage	Check for watertightness /clean or replace in case of leakage
Motors	Check	Check	Check	Check	Replace
Gearing	Check	Check	Check	Check	Check/ replace if necessary
Electronic/ settings**	Check	Check	Check	Check	Check/ replace if necessary
Transformer**	Check	Check	Check	Check	Check/ replace if necessary
Microswitches	Check	Check	Check	Check	Replace
Meter(s)* (if present)	Check and Clean	Check and Clean	Check and Clean	Check and Clean	Replace
Meter cable(s)* (if present)	Check	Check	Check	Check	Replace
Valve watertightness	Check	Check	Check	Check	Check

Items	1 year	2 year	3 year	4 year	5 year
Valve to piping watertightness	Check	Check	Check	Check	Check

* Wear parts - durability strongly affected by raw water quality and regeneration frequency.

** Electronic parts – durability strongly affected by power source quality and stability.

*** Elastomer durability is strongly affected by raw water concentration in chlorine and its derivative.

9.2.2.2 MECH controller

Items	1 year	2 year	3 year	4 year	5 year
DLFC***	Clean	Clean	Clean	Clean	Clean/ replace if necessary
Bypass (if present, contains Orings***)	Clean	Clean	Clean	Clean	Clean/replace if necessary
Piston*	Check/clean/replace if necessary	Replace	Check/clean/replace if necessary	Replace	Check/clean/replace if necessary
Seals & spacers*	Check/clean/replace if necessary	Replace	Check/clean/replace if necessary	Replace	Check/clean/replace if necessary
O-rings***	Check for watertightness /clean or replace in case of leakage	Check for watertightness /clean or replace in case of leakage	Check for watertightness /clean or replace in case of leakage	Check for watertightness /clean or replace in case of leakage	Check for watertightness /clean or replace in case of leakage
Motors	Check	Check	Check	Check	Replace
Gearing	Check	Check	Check	Check	Check/ replace if necessary
Settings**	Check	Check	Check	Check	Check
Transformer**	Check	Check	Check	Check	Check/ replace if necessary
Microswitches	Check	Check	Check	Check	Replace
Meter(s)* (if present)	Check and Clean	Check and Clean	Check and Clean	Check and Clean	Replace
Meter cable(s)* (if present)	Check	Check	Check	Check	Replace
Valve watertightness	Check	Check	Check	Check	Check
Valve to piping watertightness	Check	Check	Check	Check	Check

* Wear parts - durability strongly affected by raw water quality and regeneration frequency.

** Electronic parts – durability strongly affected by power source quality and stability.

*** Elastomer durability is strongly affected by raw water concentration in chlorine and its derivative.

9.3 Recommendations

9.3.1 Use original spare parts

Caution - material



Risk of damage due to use of non-genuine spare parts !

To ensure correct operation and safety of the device, only use original spare parts and accessories recommended by the manufacturer.

Usage of non-genuine spare parts voids all warranties.

Parts to keep in stock for potential replacements are the pistons, S&S kit, injectors, micro-switches and motors. Refer to maintenance sheet.

9.3.2 Use original approved lubricants

- Dow Corning #7 Release Agent.

9.3.3 Maintenance instructions

- Disinfect and clean the system at least once a year or if the treated water has an off-taste or an unusual odor;
- perform a hardness test every year at both inlet and treated water.

9.4 Cleaning and maintenance

9.4.1 First steps

Before any cleaning or maintenance procedure, complete the following steps:

Mandatory



These operations must be performed before any cleaning or maintenance procedure !

1. Unplug the wall-mounted transformer.
2. Shut off water supply or put bypass valve(s) into bypass position.
3. Relieve system pressure before performing any operations.

9.4.2 Controller motor replacement

1. Using a flat screwdriver, unscrew (4) and remove the cover (3).
2. Disconnect the motor (1).
3. Using a Philips screwdriver, unscrew (2) and remove the motor (1).
4. Change the motor (1).
5. Reverse above procedure steps to rebuild.

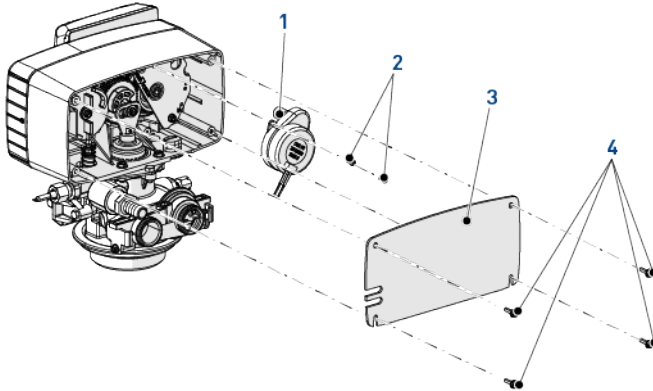

9.4.3 Controller replacement

Info



Only for SXT controller.

1. Using a Philips screwdriver, unscrew **(1)** and remove the cover **(2)** paying attention for the wire.
2. Press the board clips **(3)** and release the controller cover **(6)**.
3. Using a flat screwdriver, unscrew **(5)** and remove the controller **(4)**.
4. Remove carefully the wire connectors **(7)**.
5. Connect the new controller, see Electrical connections.
6. Reverse above procedure steps to rebuild.

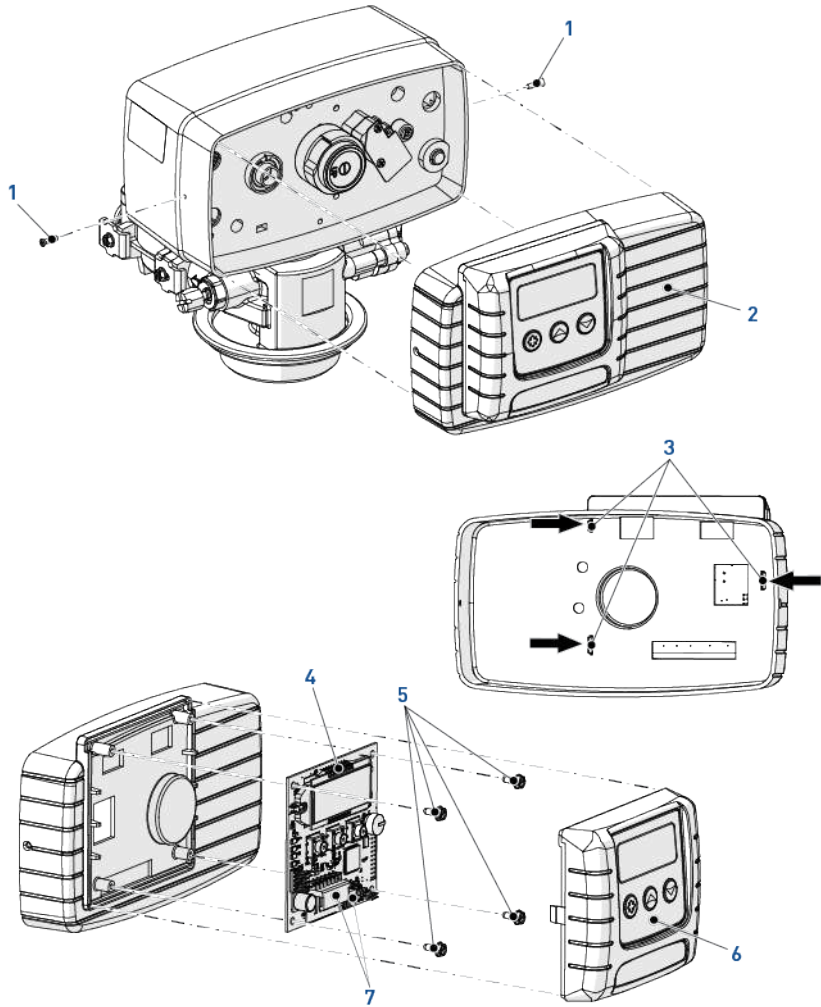

9.4.4 Power head disassembly/replacement

1. Disconnect the meter cable (1), if available.
2. Using a flat screwdriver, unscrew (5) and remove the cover (4).
3. Using a flat screwdriver, unscrew (3) and remove the washer (2).
4. Using a flat screwdriver or an 8 mm wrench, unscrew (7) and remove the power head (6) from the valve body (8).
5. Change the power head (6).
6. Reverse above procedure steps to rebuild.

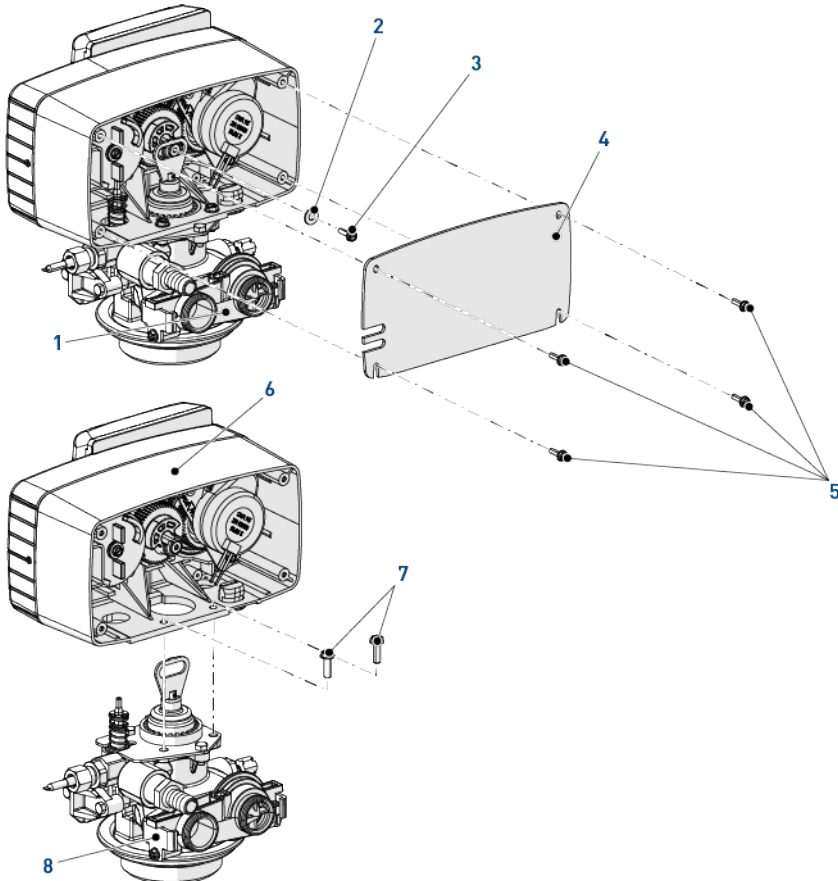

9.4.5 Piston and/or brine valve and/or seal and spacer kit replacement

1. Remove the power head, see Power head disassembly/replacement.
2. Using a flat screwdriver or an 8 mm wrench, unscrew (3) and remove the top plate (4).
3. Remove the brine valve (6) and/or the piston (5).

Caution - material



Risk of damage on piston due to wrench use !

Using a wrench on piston rod coating will cause leakages.

4. Using a small hook, remove a seal (7).
5. Using the puller (1), remove a spacer (8).
6. Repeat the two previous steps for all the seals and spacers.
7. Lubricate each new seals (7).
8. Put back a seal (7) using the stuffer (2).
9. Put back a spacer (8) using the stuffer (2).
10. Repeat the two previous steps for all the seals and spacers.
11. Lubricate the piston o-ring (5).
12. Put back the brine valve (6) and/or the piston (5).
13. Using a flat screwdriver or an 8 mm wrench, fix the top plate (4) with the screws (3).
14. Rebuild the power head, see Power head disassembly/replacement.

Caution - material



Risk of damage due to wrong lubricant use !

Do not use petroleum-based lubricants such as vaseline, oils, or hydrocarbon-based lubricants.

Use only approved silicone grease or soapy water !

9.4.5.1 Special tools needed

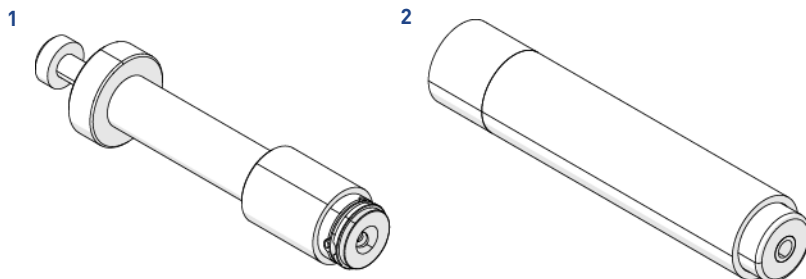

Item	Part number	Description	Packaging quantity
1	13061	Puller	1

Item	Part number	Description	Packaging quantity
2	12763	Stuffer	1

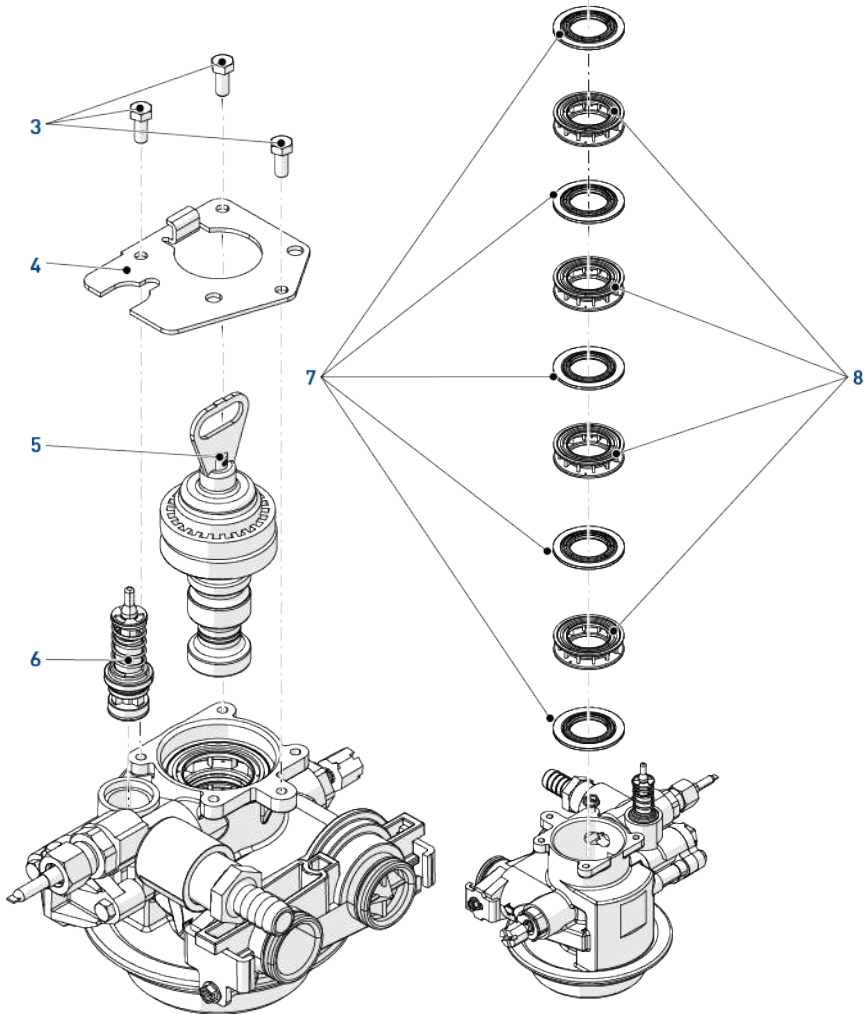

9.4.6 Micro-switches and/or drive cam replacement

9.4.6.1 SXT controller

1. Using a Philips screwdriver, unscrew (1) and remove the cover (2).
2. Disconnect the wire on the microswitches (6).
3. Using a Philips screwdriver, unscrew (8).
4. Remove the protection plate (7) and the microswitches (6).
5. Using a Philips screwdriver, unscrew (5) and remove the drive cam (4) and the washer (3).
6. Change the drive cam (4) and/or the microswitches (6).
7. Reverse above procedure steps to rebuild.

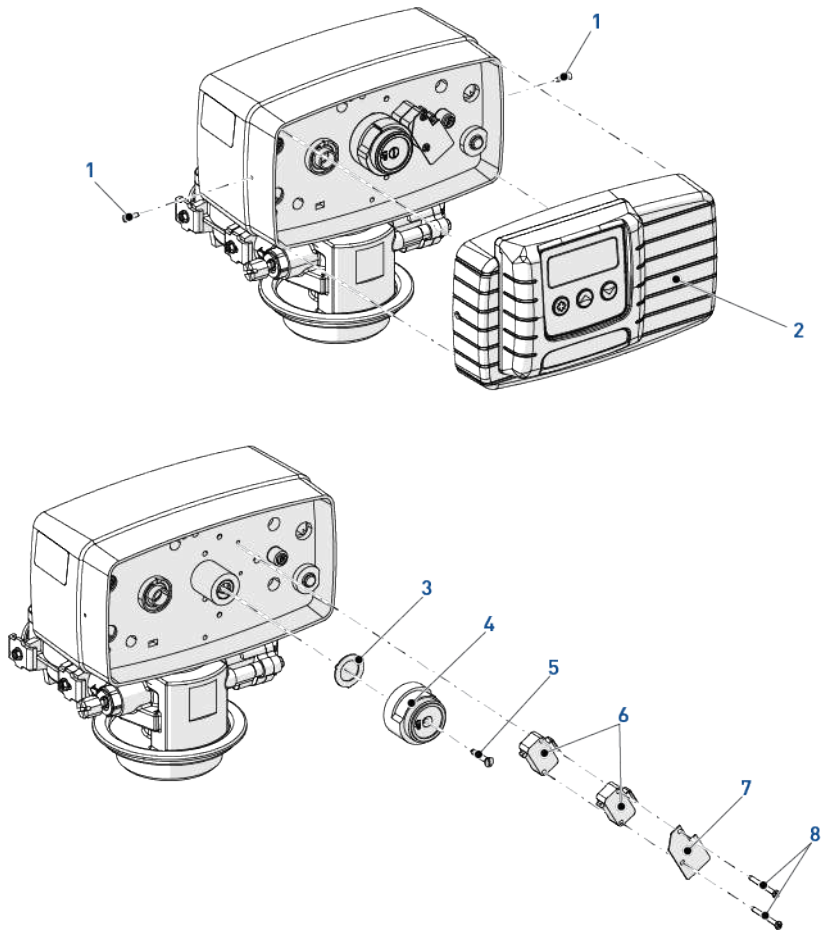

9.4.6.2 MECH controller

1. Using a flat screwdriver, unscrew (2) and remove the cover (1).
2. Using a Phillips screwdriver, unscrew (5) and extract the protection plate (4) and the micro-switch (3).
3. Reverse above procedure steps to rebuild.

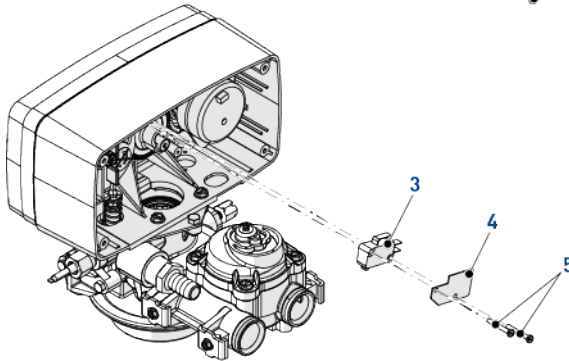
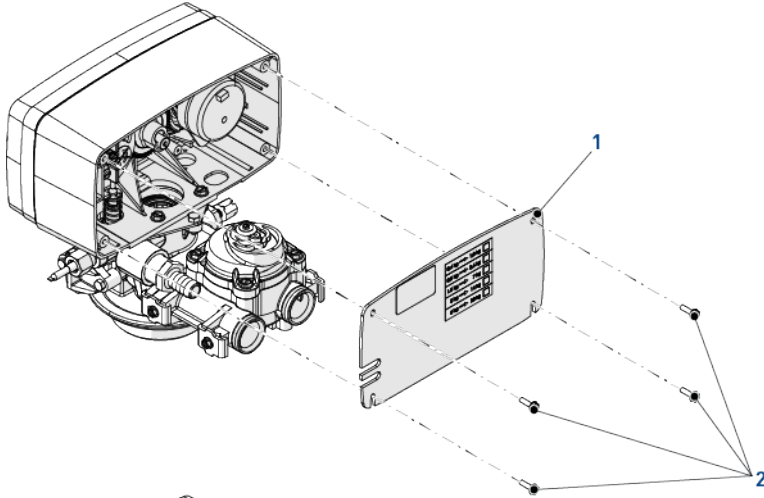

9.4.7 Brine cam replacement

1. Remove the power head, see Power head disassembly/replacement.
2. Using a flat screwdriver, unscrew (1).
3. Remove the washer (2) and the brine cam (3).
4. Change the brine cam (3).
5. Reverse above procedure steps to rebuild.

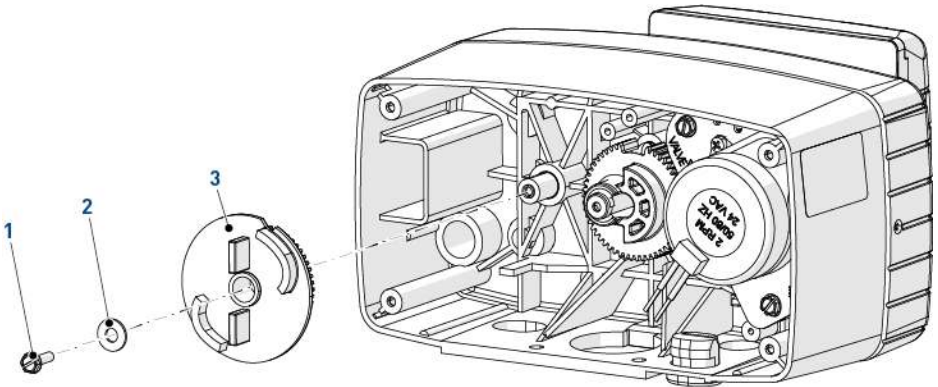

9.4.8 Injector cleaning

1. Using a flat screwdriver or an 8 mm wrench, remove the screws (6).
2. Remove the cap injector (5).
3. Remove the seal (4).
4. Remove the filter (2).
5. Using a flat screwdriver, remove the injector nozzle (3).
6. Using a flat screwdriver, remove the injector throat (1).
7. Clean or change the injector throat (1), the injector nozzle (3), the filter (2) and the seal (4).
8. Lubricate all seals with approved lubricant only.

Caution - material



Risk of damage due to wrong lubricant use !

Do not use petroleum-based lubricants such as vaseline, oils, or hydrocarbon-based lubricants.

Use only approved silicone grease or soapy water !

9. Reverse above procedure steps to rebuild.

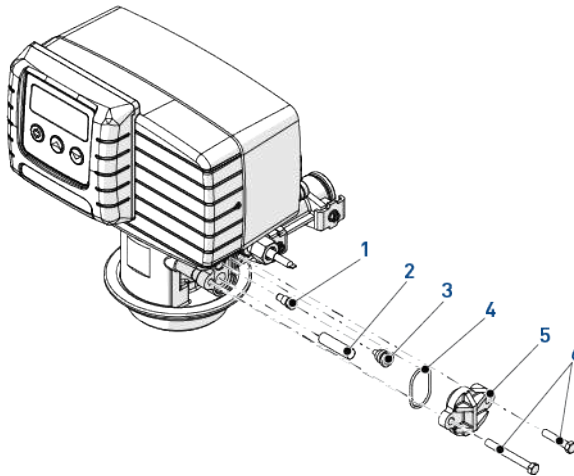

9.4.9 BLFC cleaning

1. Using a wrench, remove the BLFC holder (1).
2. Using pliers, remove the grid (4) from BLFC holder (1).
3. Remove the BLFC washer (3) from the grid (4).
4. Clean with a terry cloth or change the BLFC washer (3) and the seal (2).
5. Clean the grid (4).
6. Lubricate the seal (2) with approved lubricant only.

Caution - material



Risk of damage due to wrong lubricant use !

Do not use petroleum-based lubricants such as vaseline, oils, or hydrocarbon-based lubricants.

Use only approved silicone grease or soapy water !

7. Reverse above procedure steps to rebuild.

Mandatory



The washers (3) have to be installed with their chamfered side upfront the water stream flow.

Flow indication must be visible after the washer (3) is placed on the holder (1).

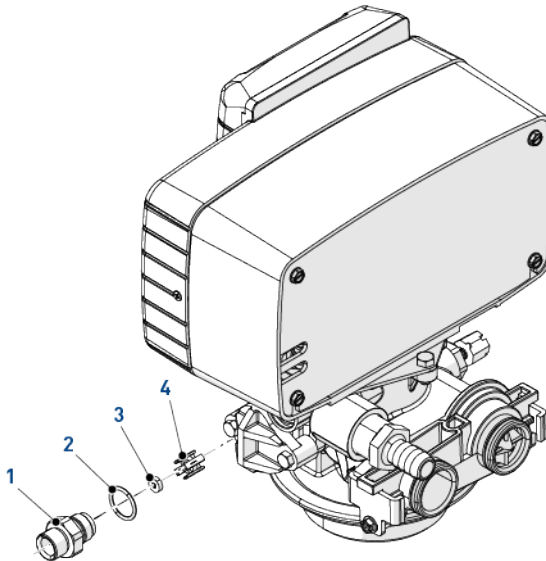

10 Troubleshooting

Problem	Cause	Solution
Softener fails to regenerate automatically	Interrupted power or switched off power source.	Restore the controller and connect to constant power source.
	Disconnected/faulty meter cable.	Check connections in the power head and on the meter cover. Change the cable.
	Defective power cord.	Replace cord.
	Defective motor.	Change motor.
	Defective controller.	Change controller.
	Blocked meter.	Clean or change meter.
	Bad programming.	Program correctly.
Softener delivers hard water	By-pass valve is open.	Close by-pass valve.
	No salt in the brine tank.	Add salt in the brine tank and keep salt level above water level.
	Plugged injector and/or filter.	Clean or replace injector and/or filter.
	Insufficient water flowing into brine tank.	Check brine tank filling time and clean flow regulator.
	Hot water tank hardness.	Repeated flushing of the hot water tank.
	Leak at the distributor hose.	Ensure the distributor tube has no cracks. Check the o-ring.
	Internal valve leak.	Change seals & spacers and/or piston assembly.
	Blocked meter.	Clean or change meter.
	Disconnected/faulty meter cable.	Check connections in the power head and on the meter cover. Change the cable.
Bad programming.	Program correctly.	
Excessive salt consumption	Improper brine refill setting.	Check use of salt and setting of brine refill.
	Too much water in the brine tank.	See problem below: Too much water in the brine tank.
	Bad programming.	Program correctly.
Water pressure drop	Iron deposit in the valve inlet.	Clean the inlet.
	Iron deposit in the valve.	Clean the valve and resin.
	Valve inlet obstructed by foreign elements.	Remove piston and clean the valve.

Problem	Cause	Solution
Resin loss through drain line	Top distributor missing or broken.	Add or replace the top distributor.
	Air in water system.	Ensure the presence of air check system in the brine tank.
	Improperly sized drain line flow control.	Size the drain line flow control correctly.
Iron presence in the valve/treated water	The resin bed is dirty.	Check backwash, brine draw, and brine refill. Regenerate more often and increase backwash cycle time.
	Iron concentration exceeds recommended parameters.	Contact your local dealer.
Too much water in the brine tank.	Plugged drain line flow control.	Clean drain line flow control.
	Plugged injector system.	Clean injector and screen, change if necessary.
	Faulty brine valve.	Change brine valve.
	Bad programming.	Program correctly.
	Controller is not cycling.	Change controller.
	Foreign material in the brine valve.	Replace brine valve seat and clean the valve.
Salted water in service line	Foreign material in the brine line flow control.	Clean brine line flow control.
	Plugged injector and/or filter.	Clean or replace injector and/or filter.
	Power head not operating properly.	Change power head.
	Foreign material in the brine valve.	Replace brine valve seat and clean the valve.
	Foreign material in the brine line flow control.	Clean brine line flow control.
	Low water pressure.	Raise inlet pressure to 1.8 bar minimum.
Bad programming.	Program correctly.	

Problem	Cause	Solution
Softener fails to draw brine	Plugged drain line flow control.	Clean drain line flow control.
	Plugged injector and/or filter.	Clean or replace injector and/or filter.
	Low water pressure.	Raise inlet pressure to 1.8 bar minimum.
	Internal valve leak.	Change seals & spacers and/or piston assembly.
	Bad programming.	Program correctly.
	Power head not operating properly.	Change power head.
Controller cycles continuously	Power head not operating properly.	Change power head.
	Faulty microswitch or wiring loom.	Change microswitch or wiring loom.
	Defective or badly set cycle cam.	Reposition or change cycle cam.
Drain flows continuously	Foreign elements in the valve.	Clean valve and check it in the different regeneration positions.
	Internal valve leak.	Change seals & spacers and/or piston assembly.
	Valve blocked in brine refill or backwash.	
	Defective or blocked motor.	Change motor and check gear teeth.
	Power head not operating properly.	Change power head.
Upper drive synchronization	Power failure while the electronic was compiling data.	System will recover automatically within a few minutes.
	The board doesn't receive the signal from the homing microswitch (motor runs for the 6 first minutes of UD display then shows ER0).	Check microswitches and associated wiring.
	Er 0 was shown, power switch off and on: UD---- is displayed at power restoration and motor runs for 6 minutes looking for its position, finally shows Er0 again if expected signals from microswitches aren't received.	

10.1 Error detection

Info



Only for SXT controller.

Errors codes appear on the service display.

Info



It can take up to 1 minute before an error can be detected and displayed.

10.1.1 Motor stall/cam sense error

Info



The valve drive takes more than 6 minutes to go to the next regeneration cycle and the board hasn't received expected signals from microswitches.

1. Unplug the unit and plug back in. Allow the controller to attempt to find position again.
2. Unplug the unit and examine the power head, especially look at homing/step microswitches and motor.
3. Verify all circuit board connections.
4. Verify the motor and gearing components are in good condition and assembled properly.
5. Check the valve and verify that the piston travels freely.
6. Replace/reassemble the various components as necessary.
7. Plug the unit back in and observe its behaviour.
8. If the error reoccurs, unplug the unit.
9. Put it into bypass.
10. Contact dealer.



10.1.2 Motor run-ON error/cycle sense error

Info



The valve performed an unforeseen cycle.

This error message is only valid until controller version 2.6.

1. Unplug the unit and plug back in. Allow the controller to attempt to find position again.
2. Unplug the unit and examine the power head.
3. Verify all circuit board connections.
4. Enter master programming mode.
5. Verify that the valve type and system type are set correctly with regard to the unit itself.
6. Step the unit to a manual regeneration.
7. Verify that it functions correctly.
8. If the error reoccurs, unplug the unit.
9. Put it into bypass.
10. Contact dealer.



10.1.3 Regeneration failure

Info



The system has not regenerated for more than 99 days or 7 days if the regeneration control type has been set to day of week.

1. Perform a manual regeneration to reset the error code.
2. If the system is metered, verify that it is measuring flow by running service water and watching for the flow indicator on the display.
3. If the unit doesn't measure flow, verify that the meter is working properly and its cable is well connected.
4. Enter master programming mode.
5. Verify that the unit is configured properly.
6. Check that system capacity has been selected.
7. Check that day override is set properly.
8. Check that meter is identified correctly.
9. If the unit is configured as a day of week system, verify that at least one day is set ON.
10. Correct the setting as necessary.



10.1.4 Memory error

Info



The controller board has a memory failure.

1. Perform a master reset.
2. Reconfigure the system via master programming mode.
3. Step the valve through a manual regeneration.
4. If the error reoccurs, unplug the unit.
5. Put it into bypass.
6. Contact dealer.



11 Spare parts and options

11.1 Valve parts list

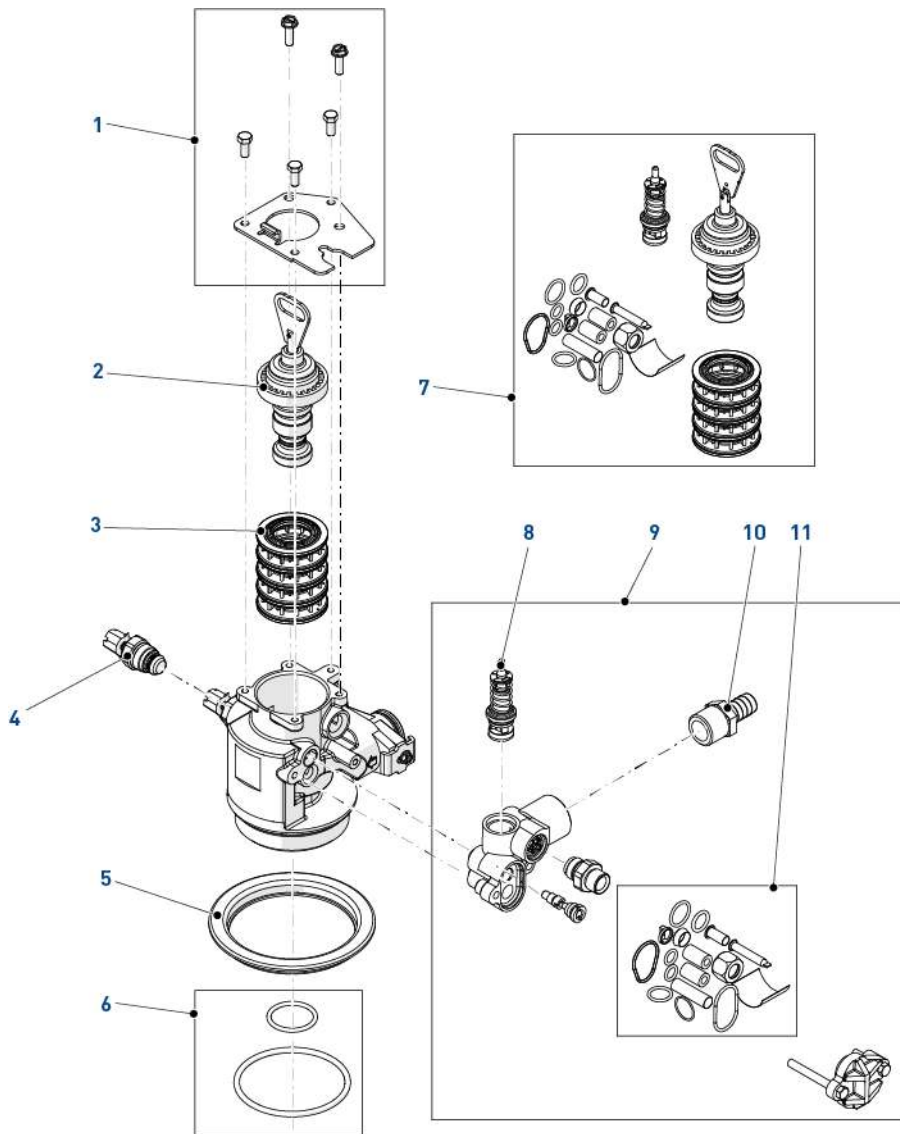

Item	Part number	Description	Packaging quantity
1	29116	End plug retainer kit 4600	1
2	24116-US	Piston assy 4600/5600	1

Item	Part number	Description	Packaging quantity
-	24117-US	Piston assy 4600/5600 LWU	1
-	18928	Piston assy 4600/5600 Filter	1
-	27077-US	Piston assy 4600SXT/5600SXT/6600/6700 DF	1
-	27077-01-US	Piston assy 4600 SXT HW	1
3	24944	S&S Kit 4600/9000 HW Upper	1
-	24115	S&S Kit Residential	1
4	24509-01	Mixing assy residential	1
-	24509-02	Mixing assy 4600 Hot Water	1
5	11965SP	Retainer tank seal 4600	10
6	29117	Kit O-rings tank adapter 4600	10
7	29127	4600 Mechanical LWU HW service kit	1
-	29128	4600 Mechanical HW service kit	1
-	29129	4600 SXT HW service kit	1
8	24114	BV assy 1600 Residential	1
9	29121	Injector assy 4600 #0/1.2/0.25 (w/washer 0.8 GPM-BLFC 0.125)	1
-	29122	Injector assy 4600 #1/1.5/0.25 (w/ washer 2 & 2.4)	1
-	29123	Injector assy 4600 #2/3.5/0.50 (w/ washer 4)	1
-	29124	Injector assy 4600 HW #0/1.2/0.25 (w/washer 0.8 GPM-BLFC 0.125)	1
-	29125	Injector assy 4600 HW #1/1.5/0.25 (w/ washer 2 & 2.4)	1
-	29126	Injector assy 4600 HW #2/3.5/0.50 (w/ washer 4)	1
10	22359SP	Hose Barb Straight Hot Water	10
11	29115	Injector service kit residential/9000/9100	1
Not shown	12794-01SP	Elbow 3/8" x 3/8"	10
Not shown	19699SP	Hose Barb 45°	10

11.2 Power head parts list

11.2.1 SXT controller

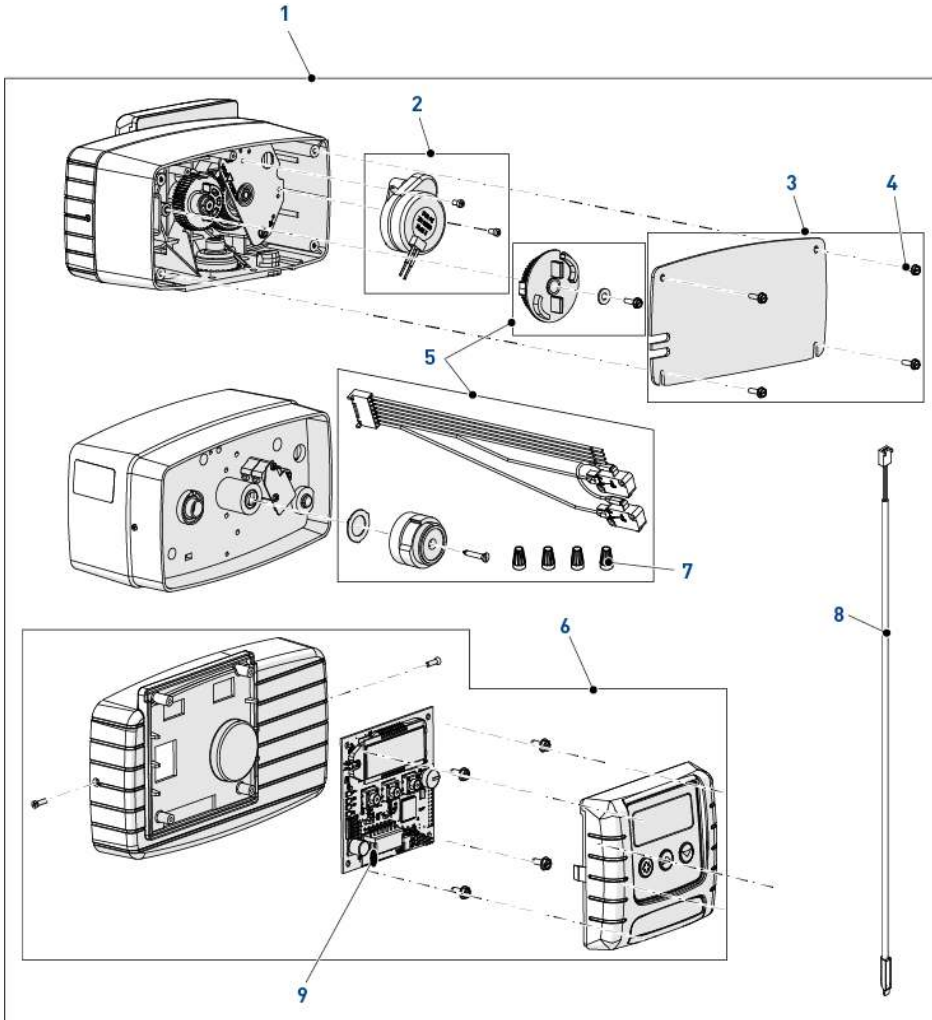

Item	Part number	Description	Packaging quantity
1	PH56SXT-003	PH 4600/5600 SXT Eco	1
2	25329	Drive Motor assy 24V/50-60Hz	1
3	29131	Kit back cover black 4600/5600/6600	1
4	13296SP	Screw	50

Item	Part number	Description	Packaging quantity
5	29132	Repair kit for residential SXT power head	1
6	BU28723	Front panel & label SXT	1
7	40422SP	Wire Nut Tan	50
8	19791-01SP	Turbine Meter Cable elec 0.450 m	10
9	BR43346-E0	Circuit board SXT programmed eco	1

11.2.2 MECH controller

11.2.2.1 Volumetric power head parts list

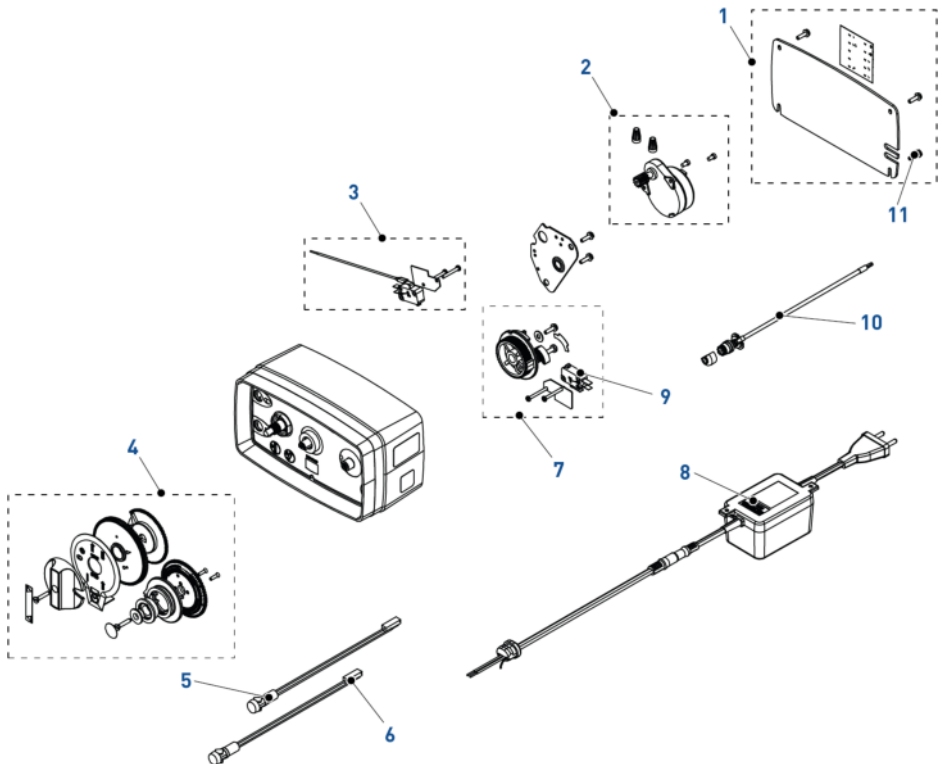

Item	Part number	Description	Packaging quantity
1	29131	Kit back cover black 4600/5600/6600	1
2	26775	Timer Motor Assy 230V/50Hz 1/30 RPM	1
-	26877	Timer Motor Assy 24V/60Hz 1/30 RPM	1
-	26778	Timer Motor Assy 24V/50Hz 1/30 RPM	1
3	BU28670	Kit microswitch electronic residential	1

Item	Part number	Description	Packaging quantity
4	29134	Repair kit for residential power head 8 & 40 m ³	1
-	29138	Repair kit for residential power head Fast Regeneration	1
5	24377SP	Red Light 4600/5600 230V	10
6	24378SP	Green Light 4600/5600 230V	10
7	29130	Kit Aux microswitch, brine cam, salt labels	1
8	BU28597	Kit transfo 10 VA 400 mA resid	1
-	BU28597-20	Kit transfo 10 VA 400 mA resid UK plug	1
-	15545	Power Cord European Black	1
9	10218SP	Microswitch	5
10	24544	Kit meter cable assy 4600/5600 8 m ³ delayed	1
11	13296SP	Screw	50

11.2.2.2 Time clock power head specific parts and assembly list

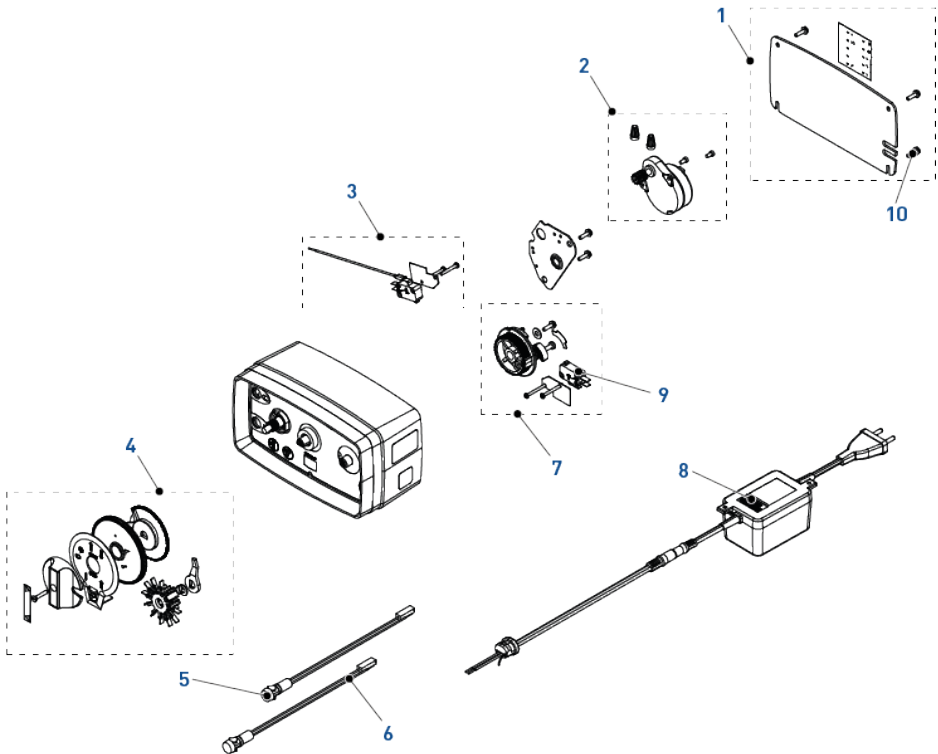

Item	Part number	Description	Packaging quantity
1	29131	Kit back cover black 4600/5600/6600	1
2	26775	Timer Motor Assy 230V/50Hz 1/30 RPM	1
-	26877	Timer Motor Assy 24V/60Hz 1/30 RPM	1
-	26778	Timer Motor Assy 24V/50Hz 1/30 RPM	1
3	BU28670	Kit microswitch electronic residential	1
4	29136	Repair kit for residential power head 12 days	1
-	29137	Repair kit for residential power head 7 days	1
5	24377SP	Red Light 4600/5600 230V	10
6	24378SP	Green Light 4600/5600 230V	10
7	29130	Kit Aux microswitch, brine cam, salt labels	1
8	BU28597	Kit transfo 10 VA 400 mA resid	1
-	BU28597-20	Kit transfo 10 VA 400 mA resid UK plug	1
-	15545	Power Cord European Black	1
9	10218SP	Microswitch	5
10	13296SP	Screw	50

11.3 Safety brine valves list

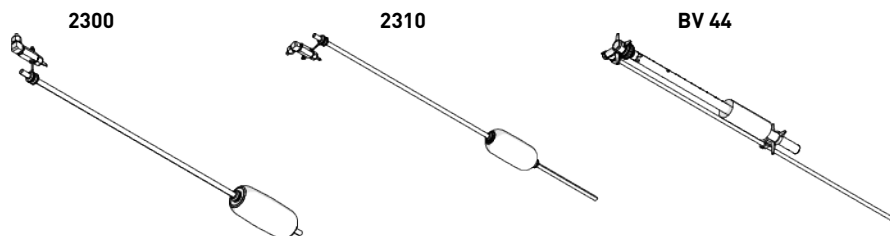

Item	Brine system	Part number	Description	Packaging quantity
-	1600	27833	Safety Brine Valve 2300 - Without Air-Check	24
-	1600	27834	Safety Brine Valve 2300 - HW - Without Air-Check	24
-	1600	60067-03	Safety Brine Valve 2310 - Without Air-Check	24
-	1600	25687	Brine Valve 44 - 914mm	10
-	1600	18961	Brine Valve 44 - 1250mm	10

11.4 Safety brine valves 2310 parts list

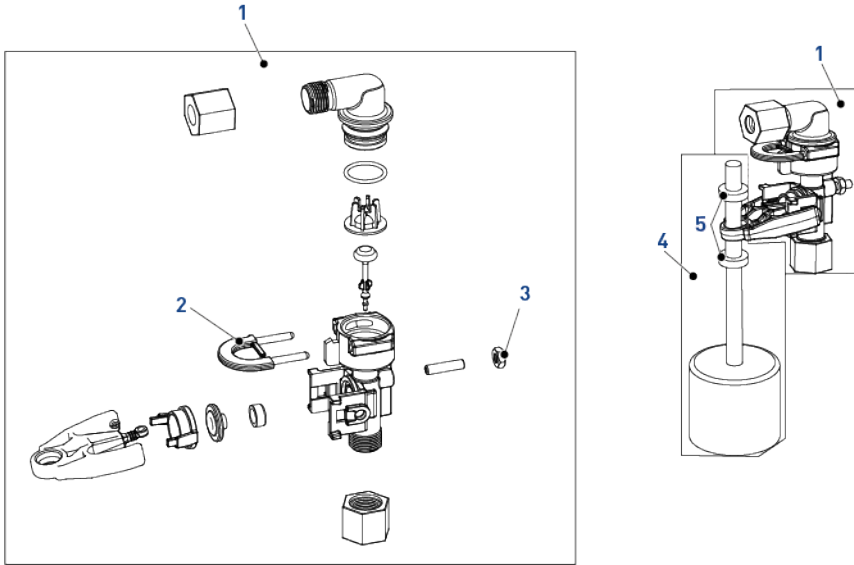

Item	Part number	Description	Packaging quantity
1	60014SP	Body Assy SBV 2310	10
2	18312SP	Retainer, drain	10
3	19805SP	Nut SBV 2310 Plastic	50
4	60068-30SP	New Float assy 2310	10
5	10150SP	Grommet pass rod 2300/2310/2350	50

11.5 Bypass valve assembly list

11.5.1 1" BSP female stainless steel bypass

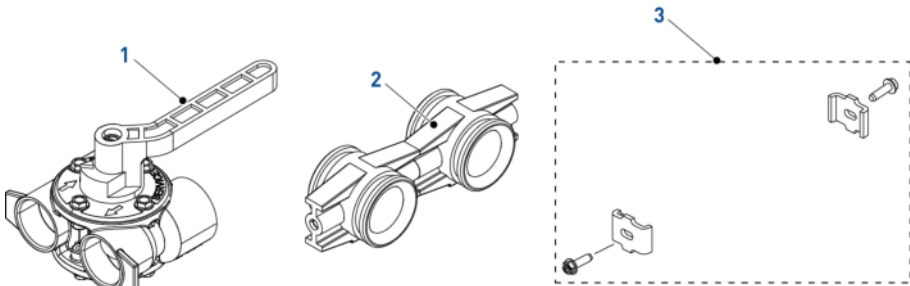

Item	Part number	Description	Packaging quantity
1	BU28502	Bypass 1" BSP Female Stainless Steel	1
2	13709	Coupling Assy residential	1
3	29104	Kit mounting/adapter 2 clips & 2 screws residential	1

11.5.2 1" BSP female brass bypass with mixing

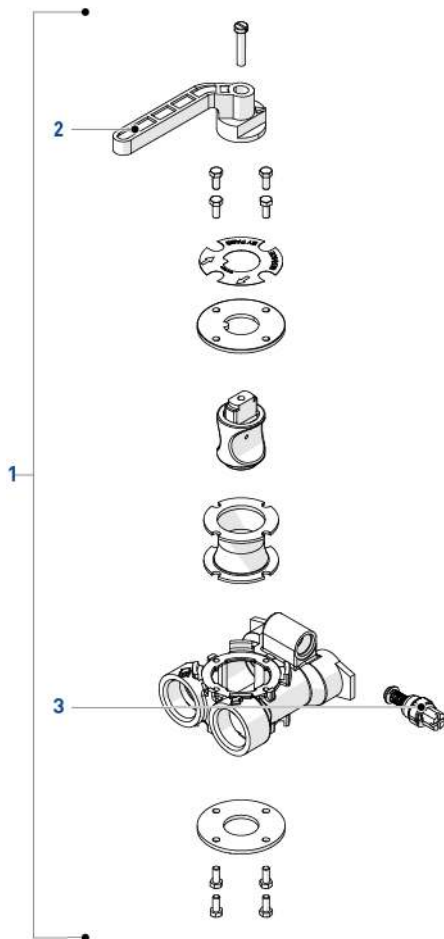

Item	Part number	Description	Packaging quantity
1	24734-10	Bypass 1" BSP female brass with mixing	1
2	26007-10	Eco bypass assy 8 m ³ & red handle	1
-	26006-10	Eco bypass assy 8 m ³ & red handle HW	1
3	24509-01	Mixing assy residential	1

Item	Part number	Description	Packaging quantity
-	24509-02	Mixing assy 4600 Hot Water	1

11.5.3 Plastic bypass (no yoke)

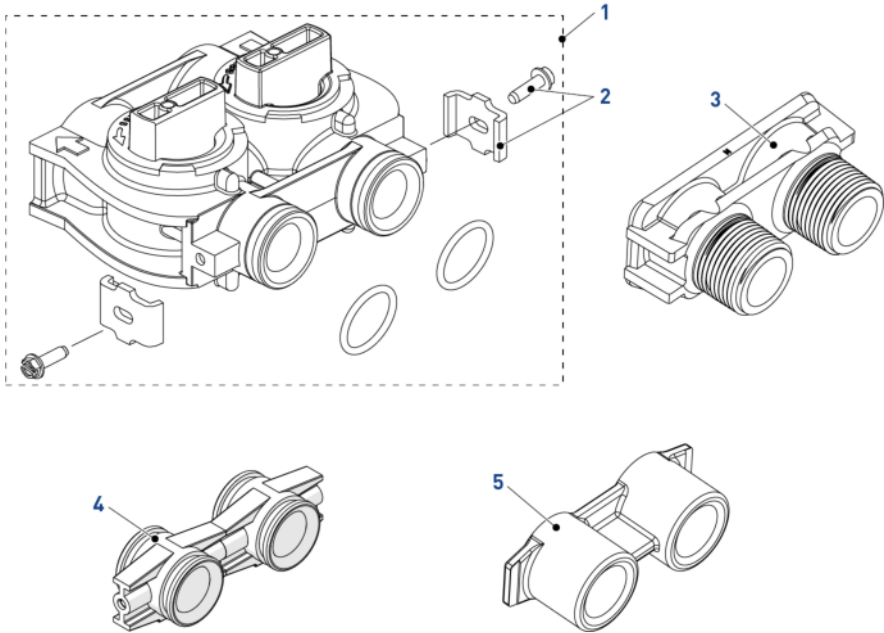

Item	Part number	Description	Packaging quantity
1	BU26054	Bypass plastic	1
2	29104	Kit mounting/adpater 2 clips & 2 screws residential/9000/9100	1
3	18706-10	Yoke, 1", BSP, male, plastic	1
-	18706-12	Yoke, 3/4", BSP, male, plastic	1
-	24689	Yoke, 3/4", BSP, male, brass	1
4	13709	Coupling Assy residential	1
5	13398-10	Yoke 1", BSP, female, brass	1

11.6 Distribution systems parts list

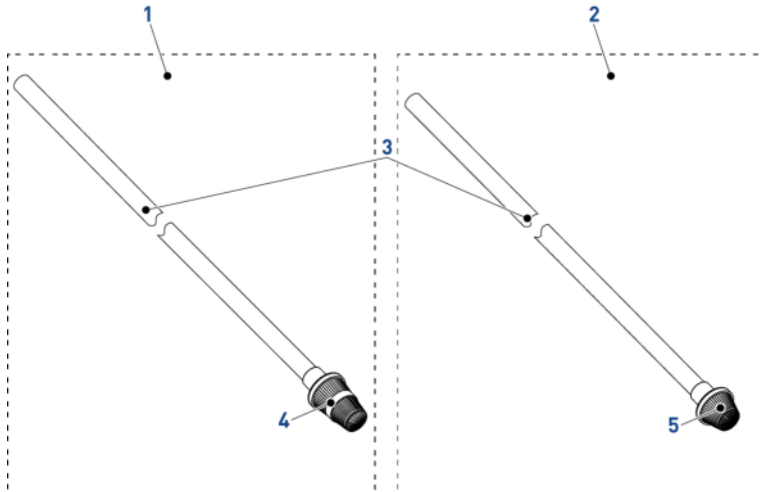

Item	Part number	Description	Packaging quantity
1	27827	Distributor assy, 1" high flow 1 m 10	24
-	25645	Distributor assy, 1" high flow 1 m 95	24
-	BU28508	Distributor assy, 1" high flow HW 1 m 10	24
-	21675	Distributor assy, 1" high flow HW 1 m 88	12
2	27828	Distributor assy, 1" UF & high capacity 1 m 10	24
-	BU28509	Distributor assy, 1" UF & high capacity HW 1 m 10	24
-	25639	Distributor assy, 1" high capacity HW 1 m 88	24
3	BU28648	Distributor tube, 1" - 1 m 85 (ACS)	1
-	BU28650	Distributor tube, 1" - 1 m 06 (ACS)	1
-	12165-01	Distributor tube, 1" - 1 m 78 HW	1
4	25360	Bottom distributor, 1" high flow	1
-	27106	Bottom distributor, 1" high flow HW	1
5	25797	Bottom distributor, 1" UF & high capacity	1
-	27109	Bottom distributor, 1" UF & high capacity HW	1

11.7 Air checks list

500

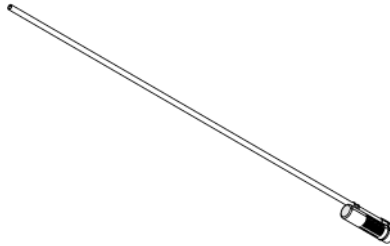

Item	Brine system	Part number	Description	Packaging quantity
-	1600	18168	Air checks 500A, 0.915m	48
-	1600	26773	Air checks 500A, 1m25	48
-	1600	23473	Air checks 500 HW	48

11.8 Meters parts list

11.8.1 SXT controller

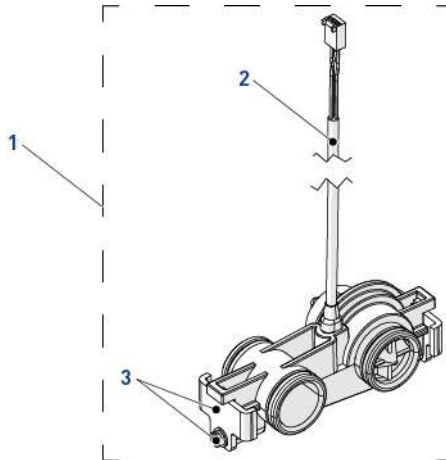

Item	Part number	Description	Packaging quantity
1	60626-01	Meter assy 3/4" turbine SXT	1
2	19791-01SP	Turbine Meter Cable elec 0.450 m	10
3	29104	Kit mounting/adpater clips & screws residential/9000/9100	1

11.8.2 MECH controller

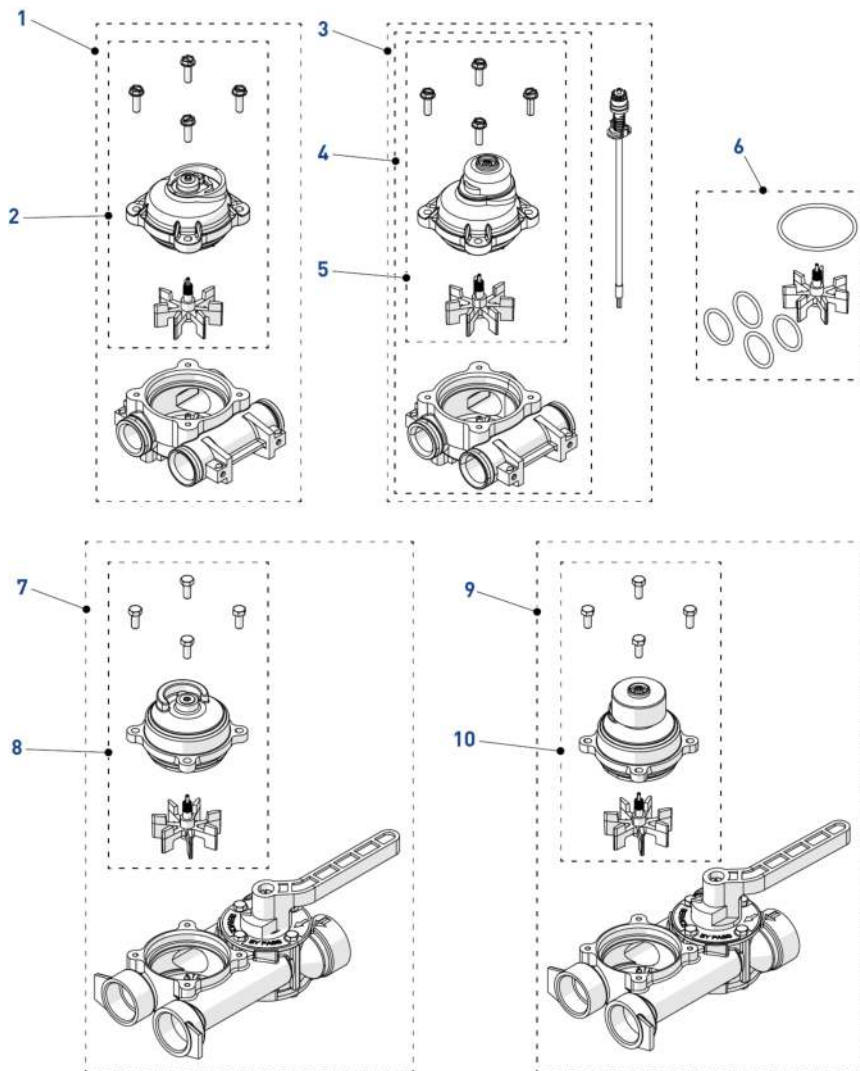

Item	Part number	Description	Packaging quantity
1	24107	Meter assy 3/4" 8 m ³ plastic	1
2	29102	Meter cover assy 8 m ³ with impeller	1
3	29103	Meter assy 3/4" 40 m ³ with meter cable	1
4	24106	Meter assy 3/4" 40 m ³ plastic 9000/9100	1
5	29164	Meter cover assy 40 m ³ with impeller 9000/9100	1

Item	Part number	Description	Packaging quantity
6	29105	Impeller & oring kit for meter assy 3/4"	1
7	26006-10	Eco bypass assy 8 m³ & red handle HW	1
8	29118	Meter cover assy brass with impeller	1
9	26007-10	Eco bypass assy 40 m³ & red handle	1
10	29120	Meter cover assy brass extended with impeller	1

11.9 Additional parts list

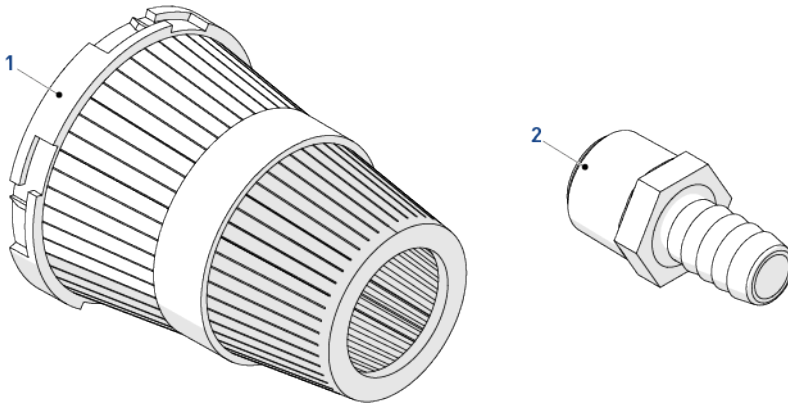

Item	Part number	Description	Packaging quantity
1	18280SP	Top distributor 1" grey	10
-	18280-01SP	Top distributor 1" wide slots natural	10
-	18280-02SP	Top distributor 1" narrow slots red	10
-	18280-10SP	Top distributor 1" HW black	10
2	22359SP	Hose Barb Straight Hot Water	10

12 Disposal

The device must be scrapped in accordance with directive 2012/19/EU or the environmental standards in force in the country of installation. The components included in the system must be separated and recycled in a waste recycling center that conforms with the legislation in force in the country of installation. This will help to reduce the impact on the environment, health, safety and help to promote recycling. Pentair does not collect used product for recycling. Contact your local recycling center for more information.



WWW.PENTAIR.EU