

Foleo 5800 XTRi



IMPORTANT SAFETY INSTRUCTIONS

Read and follow all instructions

Save these instructions

WWW.PENTAIR.EU

Table of Contents

1	Generalities	6
1.1	Scope of the documentation	6
1.2	Release management	6
1.3	Manufacturer identifier, product identification	6
1.4	Intended use	7
1.5	Abbreviations used	7
1.6	Norms	7
1.6.1	Applicable norms	7
1.6.2	Available certificates	7
1.7	Procedure for technical support	7
1.8	Copyright and Trademarks	8
1.9	Limitation of liability	8
2	Safety.....	9
2.1	Safety pictograms definition	9
2.2	Serial label location	10
2.3	Hazards	10
2.3.1	Personnel	10
2.3.2	Transport.....	11
2.3.3	Material	11
2.4	Hygiene and sanitization	11
2.4.1	Sanitary issues	11
2.4.2	Hygiene measures	13
3	Description	14
3.1	Introduction to softeners	14
3.1.1	Softening principles	14
3.1.2	Variable refill function	16
3.1.3	Variable Refil/Brining regeneration cycle (5-cycles operation).....	17
3.2	Technical specifications.....	19
3.2.1	General	19
3.2.2	Performance flow rate characteristics	19
3.3	Outline drawing	22
3.4	Description and component location	23
3.5	Softener's available options	24
3.5.1	Mixing device	24
3.6	Accessories included	24
4	Installation	25
4.1	Warnings	25

4.2	Safety notices for installation	25
4.3	Installation environnement.....	25
4.3.1	General.....	25
4.3.2	Water	25
4.3.3	Electrical	26
4.3.4	Mechanical	26
4.4	Integration constraints	27
4.5	Softener connection to piping.....	28
4.5.1	Block diagram	28
4.5.2	Installation layout.....	29
4.5.3	Tools and material required for installation	29
4.5.4	Inspection/preliminary assembly	30
4.5.5	Softener installation.....	30
4.5.6	Water supply line and bypass connections.....	31
4.5.7	Drain line connection	34
4.5.8	Overflow line connection.....	35
4.6	Electrical connection	36
4.6.1	XTRi controller connection	36
5	Programming	37
5.1	Home screen & commands	37
5.2	Quick program guide	39
5.3	Touchscreen controller quick start	43
5.3.1	Format screen.....	43
5.3.2	Assistance name screen.....	44
5.3.3	Assistance phone screen.....	45
5.3.4	Assistance interval screen.....	45
5.3.5	Day and time screen	46
5.3.6	User assistance screen.....	46
5.3.7	Settings screen	47
5.3.8	Master setting screens	48
5.4	Master setting programming.....	50
5.4.1	Format screen.....	50
5.4.2	Valve screen	51
5.4.3	Regeneration screen.....	53
5.4.4	Relay output screen	56
5.4.5	Meter screen	56
5.4.6	Settings review.....	57
5.4.7	Water Saver Regen screen	57
5.4.8	Remote Regeneration screen	58
5.4.9	Chlorine generation screen	58
5.4.10	Non-factory setting	59
5.5	Diagnostics.....	59
5.5.1	Error log	61
5.6	Resetting the controller.....	61
5.7	Pentair application setup.....	62

5.7.1	Pairing the Foleo water softener with Wi-Fi Devices.....	62
5.7.2	Sign up.....	62
5.7.3	Sign in.....	65
5.7.4	Create a profile.....	66
5.7.5	Add a device.....	67
6	Commissioning	71
6.1	Softener commissioning.....	71
6.1.1	Water filling, draining and waterproofness inspection.....	71
6.1.2	Quick cycling.....	71
6.1.3	Startup.....	72
6.2	Cleaning, disinfection and sanitization.....	72
6.2.1	Cleaning of softeners.....	72
6.2.2	Disinfection with sodium or calcium hypochlorite.....	72
7	Operation.....	74
7.1	Display during operation.....	74
7.2	Display during regeneration.....	74
7.3	Controller operation during programming.....	74
7.4	Manual regeneration.....	75
7.5	Operation during a power failure.....	75
7.6	Remote lockout.....	76
7.7	Sleep mode.....	76
8	Maintenance	77
8.1	General system inspection.....	77
8.1.1	Water quality.....	77
8.1.2	Mechanical checks.....	77
8.1.3	Regeneration test.....	78
8.2	Recommended maintenance plan.....	78
8.2.1	Maintenance instructions.....	80
8.3	Adding salt.....	80
8.4	Recommendations.....	81
8.4.1	Use original spare parts.....	81
8.4.2	Use original approved lubricants.....	81
8.5	Cleaning and maintenance.....	81
8.5.1	First steps.....	81
8.5.2	Softener cover removal.....	82
8.5.3	Brine tank, brine well, safety brine valve and air check cleaning.....	83
8.5.4	Injector and injector screen cleaning.....	85
8.5.5	Controller replacement.....	86
8.5.6	IoT board replacement.....	87
8.5.7	Brine valve and/or piston and seals & spacers replacement.....	88
8.5.8	Other wear and tear parts.....	90
9	Troubleshooting	98

9.1	Controller	98
9.1.1	Error detection	98
9.1.2	Error alerts.....	98
9.2	Valve	100
9.3	System.....	101
10	Spare parts	104
10.1	Softener	104
10.1.1	Safety brine valves 2310 parts list	106
10.2	Valve	107
10.2.1	Valve body parts list	107
10.2.2	Power head parts list	108
10.2.3	Paddle meter parts list	108
10.3	Piping.....	109
11	Disposal	110

1 Generalities

1.1 Scope of the documentation

The documentation provides the necessary information for appropriate use of the product. It informs the user to ensure efficient execution of the installation, operation or maintenance procedures.

The content of this document is based on the information available at the time of publication. The original version of the document was written in English.

For safety and environmental protection reasons, the safety instructions given in this documentation must be strictly followed.

The manufacturer reserves the right to make changes at any time without notice.

This manual is a reference and will not include every system installation situation. The person installing this equipment should have:

- training in the Foleo series, XTRi controllers and water treatment appliances installation;
- knowledge of water conditioning and how to determine proper controller settings;
- basic plumbing skills.

This document is available in other languages on <https://www.pentair.eu/product-finder/product-type/softeners>.

1.2 Release management

Revision	Date	Authors	Description
A	05.09.2018	BRY/FLA	First edition.
B	09.09.2019	BRY	Corrections.
C	15.11.2019	BRY	Bleam sticker change.
D	24.09.2021	BRY	New cover.
E	22.10.2021	ABO	New design.
F	28.04.2025	BRY	XTRi controller.
G	03.03.2026	STF	General corrections, Update of the manufacturer's address.

1.3 Manufacturer identifier, product identification

Manufacturer: **EMEA legal entity**
 Pentair Manufacturing Italy S.R.L.
 Via Tiziano 32
 20145 Milano (MI)
 Italy

Product identification: Foleo 5800 XTRi

1.4 Intended use

- For domestic use only;
- the water softener series Foleo may only and exclusively be used for residential water softening under specified conditions, see Water [→Page 25];
- the water softener series Foleo protects water pipes and connected water-carrying systems from scaling, respectively from malfunctions and damage caused by scaling;
- the water softener series Foleo is designed for continuous supply of water for different family sizes depending on the chosen model.

1.5 Abbreviations used

Assy	Assembly
DLFC	Drain Line Flow Controller
Refill Controller	Brine Line Flow Controller
Regen	Regeneration
SBV	Safety Brine Valve
UF	Up Flow

1.6 Norms

1.6.1 Applicable norms

Comply with the following guidelines:

- 2014/35/UE: Low Voltage Directive;
- 2014/30/UE: Electromagnetic compatibility;
- 2011/65/UE: Restriction of use of certain hazardous substances in electrical and electronic equipment (RoHS);
- UNI EN ISO9001.

Meets the following technical standards:

- EN IEC 61326-1;
- EN IEC 61010-1.

1.6.2 Available certificates

- CE;
 - DM174;
 - ACS.
- Please find beside the certifications for some of our product families. Please note that this list is not an exhaustive list of all our certifications. In case of need for more information please contact us.



1.7 Procedure for technical support

Procedure to follow for any technical support request:

1. Collect the required information for a technical assistance request.

- ⇒ Product identification (see Serial label location [→Page 10] and Recommendations [→Page 81]).
- ⇒ Description of the device problem.

2. Please refer to the Troubleshooting [→Page 98]. If the problem persists contact your local tech support.

1.8 Copyright and Trademarks

All indicated Pentair trademarks and logos are property of Pentair. Third party registered and unregistered trademarks and logos are the property of their respective owners.

© 2026 Pentair. All rights reserved.

1.9 Limitation of liability

Pentair Water Treatment EMEA products benefit, under specific conditions, from a manufacturer warranty that may be invoked by Pentair's direct customers. Users should contact the vendor of this product for applicable conditions and in case of a potential warranty claim.

Any warranty provided by Pentair regarding the product will become invalid in case of:

- installation done by a non-water-professional;
- improper installation, improper programming, improper use, improper operation and/or maintenance leading to any kind of product damages;
- improper or unauthorized intervention on the controller or components;
- incorrect, improper or wrong connection/assembly of systems or products with this product and vice versa;
- use of a non-compatible lubricant, grease or chemicals of any type and not listed by the manufacturer as compatible for the product;
- failure due to wrong configuration and/or sizing.

Pentair accepts no liability for equipment installed by the user upstream or downstream of Pentair products, as well as for process/production processes which are installed and connected around or even related to the installation. Disturbances, failures, direct or indirect damages that are caused by such equipment or processes are also excluded from the warranty. Pentair shall not accept any liability for any loss or damage to profits, revenues, use, production, or contracts, or for any indirect, special or consequential loss or damage whatsoever. Please refer to the Pentair List Price for more information about terms and conditions applicable to this product.

2 Safety

2.1 Safety pictograms definition

DANGER



This combination of symbol and keyword indicates an imminently hazardous situation that will result in serious or fatal injury if not avoided.

WARNING



This combination of symbol and keyword indicates a potentially hazardous situation that can result in serious or fatal injury if not avoided.

CAUTION



This combination of symbol and keyword indicates a potentially hazardous situation that can result in minimal or minor injury if not avoided.

Caution - material



This combination of symbol and keyword indicates a potentially hazardous situation that can result in material damage if not avoided.

Prohibition



Mandatory advice to follow.

Mandatory



Applicable guideline, measure!

Info



Informative comment

2.2 Serial label location

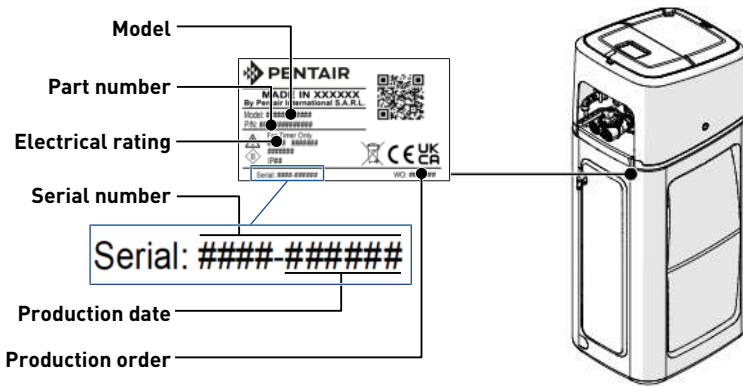

Mandatory



Ensure that the serial label and the safety labels on the device are completely legible and clean!

2.3 Hazards

All the safety and protection instructions contained in this document must be observed in order to avoid temporary or permanent injury, damage to property or environmental pollution.

At the same time, any other legal regulations, accident prevention and environmental protection measures, as well as any recognized technical regulations relating to appropriate and risk-free methods of working which apply in the country and place of use of the device must be adhered to.

Any non-observation of the safety and protection rules, as well as any existing legal and technical regulations, will result in a risk of temporary or permanent injury, damage to property or environmental pollution.

2.3.1 Personnel

CAUTION



Risk of injury due to improper handling!

Only qualified and professional personnel, based on their training, experience and instruction as well as their knowledge of the regulations, the safety rules and operations performed, are authorized to carry out necessary work.

WARNING



Appliance

This appliance can be used by children aged from 8 years and above and persons with reduced physical, sensor or mental capabilities or lack of experience and knowledge if they have been given supervision or instruction concerning use of the appliance in a safe way and understand the hazards involved.

 **WARNING**

Children

Children shall not play with the appliance.

Cleaning and salt refill shall not be made by children without supervision.

Mandatory

Any other maintenance operation must be carried out only by qualified and professional personnel!

2.3.2 Transport

The following points must be observed to ensure proper operation of the system:

- do not lay down or flip over the softener at any time. The media may paste to the upper distributor thus obstructing its slots or enter the valve and may therefore compromise the softener operation;
- pay attention not to hit the softener;
- use all the safety lifting systems to move the softener;
- do not lift the softener by the valve or bypass.

2.3.3 Material

The following points must be observed to ensure proper operation of the system and the safety of user:

- beware of high voltages present on the transformer (100 – 240 VAC);
- do not put your fingers in the system (risk of injuries with moving parts and shock due to electric voltage).

2.4 Hygiene and sanitization

2.4.1 Sanitary issues

Preliminary checks and storage

- Check the integrity of the packaging. Check that there is no damage and no signs of contact with liquid to make sure that no external contamination occurred;
- check that the brine tank and the brine well are clean and free from burr, debris or any scraps;
- the packaging has a protective function and must be removed just before installation. For transportation and storage, appropriate measures should be adopted to prevent the contamination of materials or the objects themselves.

Assembly

- Assemble only with components which are in accordance with DM 174 and ACS or any local norm/certification;
- Assemble only with components which are in accordance with drinking water standards;

- after installation and before use, perform one or more manual regenerations in order to clean the media bed. During such operations, do not use the water for human consumption. Perform a disinfection of the system in the case of installations for treatment of drinking water for human use.

Info

This operation must be repeated in the case of ordinary and extraordinary maintenance.

It should also be repeated whenever the system remains idle for a significant time.

Info

Valid only for Italy

In case of equipment used in accordance with the DM25, apply all the signs and obligations arising from the DM25.

2.4.2 Hygiene measures

DANGER



Do not use with water that is micro-biologically unsafe or of unknown quality without adequate disinfection before or after the softener.

WARNING



Water softeners using sodium chloride for regeneration will add sodium to the water.

Person who are on sodium-restricted diets should consider the added sodium as part of their overall sodium intake.

Disinfection

- The materials used for the construction of our products meet the standards for use with potable water; the manufacturing processes are also geared to preserving these criteria. However, the process of production, distribution, assembly and installation, may create conditions of bacterial proliferation, which may lead to odor problems and water contamination;
- it is therefore strongly recommended to sanitize the products. See Cleaning, disinfection and sanitization [[→Page 72](#)];
- maximum cleanliness is recommended during the assembly and installation;
- for disinfection, use Sodium or Calcium Hypochlorite and perform a manual regeneration.

3 Description

3.1 Introduction to softeners

3.1.1 Softening principles

Softening is an ion exchange process where the hard ions are getting exchange by soft ions, typically sodium or potassium. This is achieved by placing the water in contact with an ion exchange resin and ensuring the contact time is appropriate for the flow rate to produce.

The basic chemistry of softening resins is very simple: the resin is made of small polymer beads with chemical functionality that selectively captures the divalent ions (such as Ca^{2+} and Mg^{2+} - hardness ions) and releases in exchange less tightly held monovalent ions, usually sodium (Na^+) or less frequently potassium. Here below is shown the chemical reactions mechanism for softening:

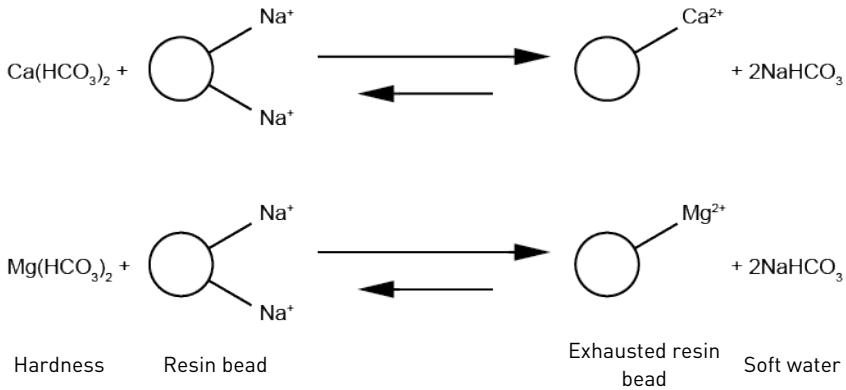

The \rightleftharpoons means that under certain conditions, the reactions can be reversed. This is due to the equilibrium between the water composition and the amount of hardness that can be removed. This reverse reaction is observed at different kinetics and at high monovalent ions concentration. Usually for softening this conditions are obtained using concentrated NaCl (or KCl) solutions that are put in contact with the resin. This is called regeneration:

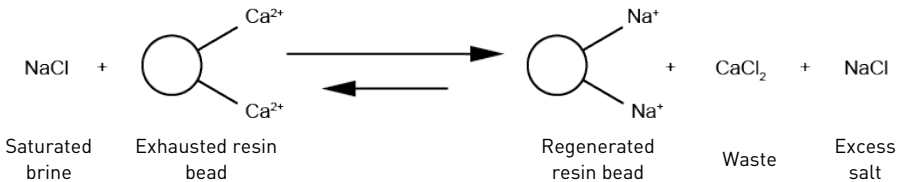

The service and regeneration reaction can be done over and over, so softening systems last years.

A softener consists of different components:

- a tank, filled with softening resin;
- a valve, that will direct the inlet water flow on the resin bed so that the softening or regeneration reaction can take place;
- a timer, that will control when the regeneration phases have to be done;

- a brine tank, where saturated brine solution is prepared for the regenerations.

The present softener will simply allow the previously described reaction to happen, alternating softening period of few days with regeneration that may last up to few hours depending on setting done. The softener is equipped with a controller that will trigger automatically the different phases of service and regeneration upon the programming done.

The valve configuration has been chosen to be in accordance with the volume of resin contained in the tank. Do not intend to modify it or you may cause kinetics changes and may cause regeneration malfunction.

In order to ensure proper softener function, make sure it always contains salt in the brine tank and remains electrically powered. Softener installation, start up and programming must be done by trained professional water treatment specialist. Incorrect installation or wrong programming may cause softener malfunctions or even damage the softener and its components.

Respect programming recommendations for each softener size in order to achieve best optimized softener performances.

Softener requires periodical cleaning/maintenance operations to ensure proper function over years. Those are described in the present manual on chapter Maintenance [[→Page 77](#)].

3.1.2 Variable refill function

The Foleo softener series is designed to feature a variable refill for each regeneration. This is meant to optimize the salt consumption of the water softener and allow yearly salt savings up to 30 % average* for the same volume of softened water therefore reducing the cost as well as the environmental impact of discharging salt to the drain.

How does this work:

The Foleo series feature volumetric delayed regeneration with reserve, meaning that the controller will plan the regeneration before complete capacity depletion based on registered water usage. Therefore when the regeneration is initiated, the capacity is actually not totally depleted. The XTRi controller will take into account the capacity that was really used and will refill the brine tank so that only what has been used for real is regenerated. The refill time is automatically calculated by the controller at each regeneration, using the BLFC rate programmed in the electronic (0.125 for 10 and 15 liters / 0.25 gpm for 20 and 30 liters).

After the variable refill is performed, the softener will return to service for the programmed duration of the Pause cycle (0 - 240 min). This time is used to allow refilled water to dissolve salt and become saturated brine. Be sure to program a sufficient duration according to your local conditions and salt type.

For best performance prefer to set up a regeneration time where there is low to no water consumption.

As an example, assuming the XTRi has a fixed reserve of 30 % of the initial full capacity. Depending on how much water is used of this fixed reserve (let's assume 10 %, meaning 20 % capacity left), the XTRi will calculate a refill time so that only 80 % of the total theoretical brine quantity is produced, saving therefore 20 % salt for this regeneration.

This variable refill function, combined with the upflow regeneration mode of Foleo's series where brine is injected from bottom to top in a packed resin bed at low velocity is ensuring the best optimized performances and savings in water softeners segment.

Info



Any manually started regeneration will initiate a regeneration with 100 % of the theoretical brine quantity to produce regardless from the water usage for the current service cycle. Should a controller initiated regeneration (including remote signal started regenerations and days override regeneration) start while less than 10 % of the capacity is used, in any case the calculated refill time will correspond to a minimum of 10 % of the total theoretical brine quantity.

*Compared to a standard downflow softener with optimized programming and configuration.

3.1.3 Variable Refill/Brining regeneration cycle (5-cycles operation)

Service — Normal Use

Untreated water is directed down through the resin bed and up through the riser tube. The hardness ions attach themselves to the resin and are removed from the raw water being exchanged on the resin beads against sodium ions. The water is conditioned as it passes through the resin bed.

Brine tank refill — Cycle C1

Water is directed to the brine tank, at a rate controlled by the refill controller [BLFC], to create brine for the next regeneration. Refill duration is calculated by the controller on the basis of real water consumption. During brine refill, treated water is available at the valve outlet.

Service — Cycle C2

After the refill, the valve comes back in to service position and stays as long as needed for brine saturation.

Brine draw & slow rinse — Cycle C3

The valve directs water through the brine injector and brine is drawn from the brine tank. The brine is then directed down through the riser tube and up through the resin bed to the drain. The hardness ions are replaced by sodium ions and are sent to the drain. The resin is regenerated during the brine cycle. Then the slow rinse phase starts.

Backwash — cycle C4

The flow of water is reversed by the valve and directed down through the riser tube and up through the resin bed. During the backwash cycle, the bed is expanded and debris is flushed to the drain, while the media bed is remixed.

Rapid rinse — cycle C5

The valve directs water down through the resin bed and up through the riser tube to the drain. Any residual brine is rinsed from the resin bed, while the media bed is recompactad.

Info



For illustration purpose only.

Always verify inlet and outlet marking on the valve.

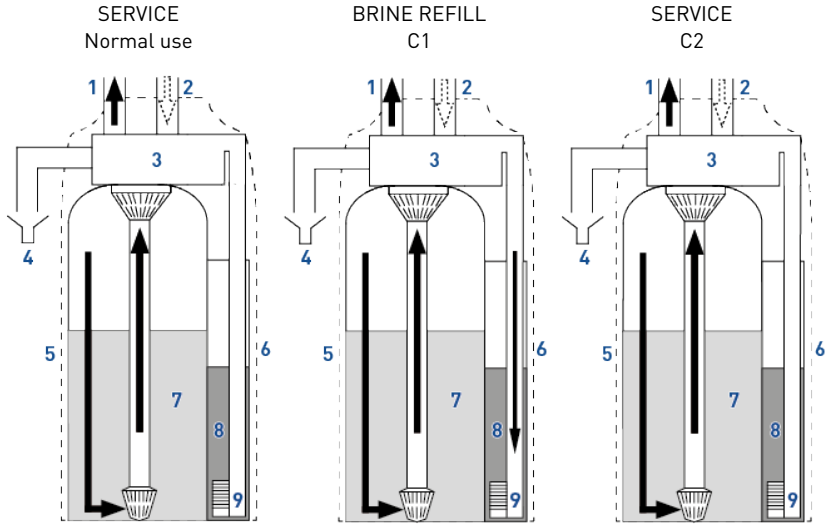

BRINE DRAW/SLOW RINCE
C3

BACKWASH
C4

RAPID RINCE
C5

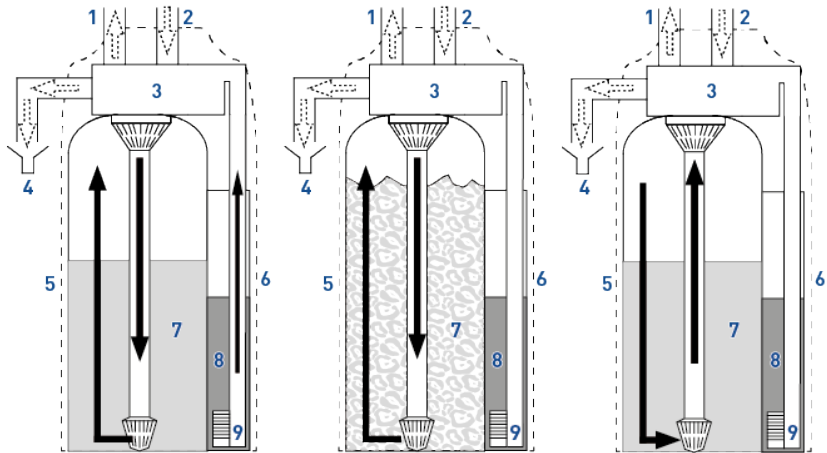

→ Soft water

⋯→ Hard water

- 1 Inlet
- 2 Outlet
- 3 Valve

- 4 Drain
- 5 Media tank
- 6 Brine tank

- 7 Media bead
- 8 Brine
- 9 SBV + air check

3.2 Technical specifications

3.2.1 General

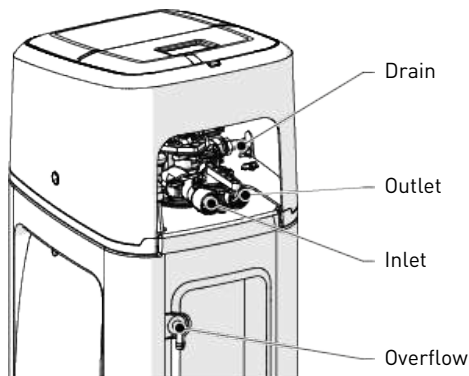

Softener type

Foleo 5800 XTRi	10	15	20	30
-----------------	----	----	----	----

Design specifications/ratings

Softener cabinet	ABS			
Tank body	Glass fiber reinforced HDPE			
Valve body	Glass-filled Noryl® - NSF listed material			
Rubber components	Compounded for cold water - NSF listed material			
Valve material certification	WQA Gold Seal Certified to ORD 0902, NSF/ANSI 44, CE, ACS			
Volume of resin	10 L	15 L	20 L	28 L
Approximative shipping weight	12 kg	18 kg	24 kg	35 kg
Salt storage	15 kg	15 kg	25 kg	25 kg
Operating pressure	1.4 - 8.0 bar			
Hydrostatic test pressure	20 bar			
Water temperature	1 - 43 °C			
Ambient temperature	0 - 52 °C			

3.2.2 Performance flow rate characteristics

Info



Flow rates are indicative data. Maximum flow rate to produce in order to respect the required service velocity for an optimal ion exchange upon resin manufacturers recommendation, regardless of the inlet pressure.

Nominal (residual hardness 0°f)	0.60 m ³ /h	0.90 m ³ /h	1.20 m ³ /h	1.68 m ³ /h
---------------------------------	------------------------	------------------------	------------------------	------------------------

Nominal (residual hardness 5-10°F)	0.72 m ³ /h	1.08 m ³ /h	1.44 m ³ /h	2.02 m ³ /h
Peak (residual hardness 5-10°F)	1.00 m ³ /h	1.50 m ³ /h	2.00 m ³ /h	2.80 m ³ /h

Softening	10	15	20	30
Number of people	1-2	3-4	5-6	7-8

Capacity & salt consumption for the different salt dosage setting

Softener	Foleo 10	Foleo 15
Salt dosage (g/L of resin)	80	80
Salt amount per regen (kg)*	0.8	1.2
Softener capacity [°Fm ³]	40.6	60.9
Capacity in m ³ for 30 °f inlet water hardness and 10 °f residual hardness setting	2.03	3.04
Average estimated salt savings compared to maximum yearly salt consumption that would have a standard softener regenerating with 80 g/L _{resin} calendar override set on 4 days, reserve at 20 %	29.3 %	

Softener	Foleo 20	Foleo 30
Salt dosage (g/L of resin)	80	80
Salt amount per regen (kg)*	1.6	2.24
Softener capacity [°Fm ³]	81.2	113.7
Capacity in m ³ for 30 °f inlet water hardness and 10 °f residual hardness setting	4.06	5.68
Average estimated salt savings compared to maximum yearly salt consumption that would have a standard softener regenerating with 80 g/L _{resin} calendar override set on 4 days, reserve at 20 %	29.3 %	

*Foleo is featured with variable refill therefore the salt quantity required is calculated by the controller at each regeneration start. This maximum amount corresponds to cases where 100 % of the capacity would have been exhausted or to what a standard softener without variable refill would consume.

Info

This example is calculated for a salt dosage fop 80 g/L_{resin}*. Should the inlet hardness be grated the 30 °f it may be required to increase the salt dosage to obtain a proper resin bed re-generation. The same simulation with 120 g/L_{resin} lead to an estimated average salt saving of 35,5 %, while the same simulation done at 160 g/L lead to an estimated salt saving of 46 %.

Softener connections

Inlet/Outlet	1"
Drain line	½" O.D.
Overflow drain line	½"

Electrical

Transformer input voltage	100 to 240 VAC, 50/60 Hz, 0.8A, class II
Transformer output voltage	12 VDC
Softener max. power consumption	30.7 W
Protection rating	IP 20
Transient overvoltages	within the limits of category II
Pollution Degree	3

Temporary overvoltages must be limited in duration and in frequency.

3.3 Outline drawing

Foleo 10 and 15 models

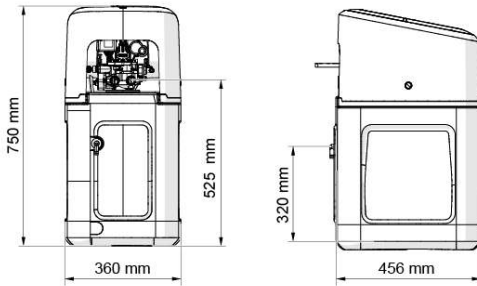

Foleo 20 and 30 models

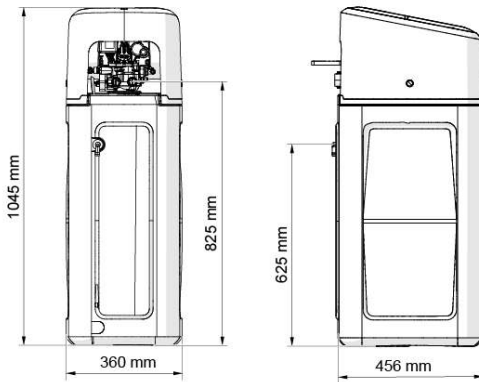

Foleo all models

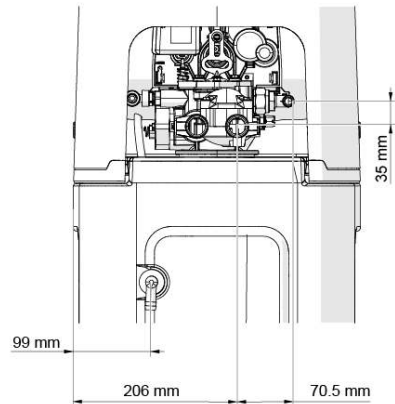

3.4 Description and component location

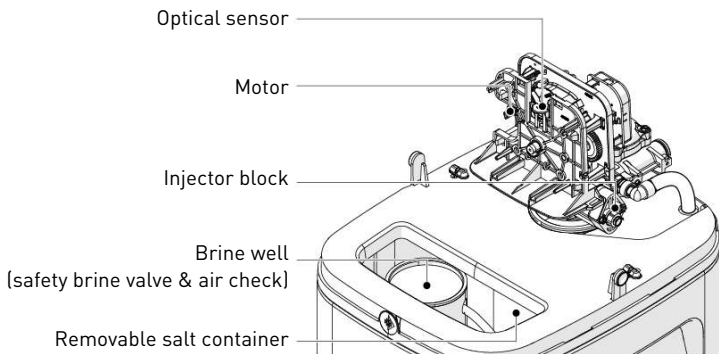
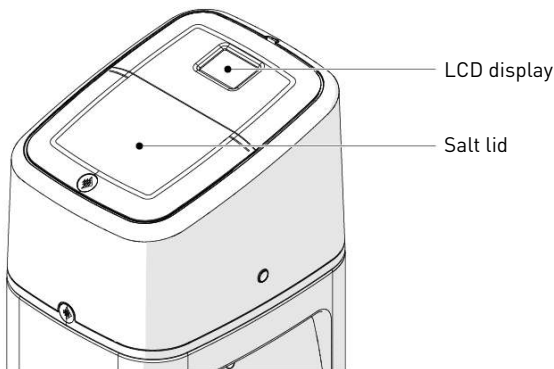
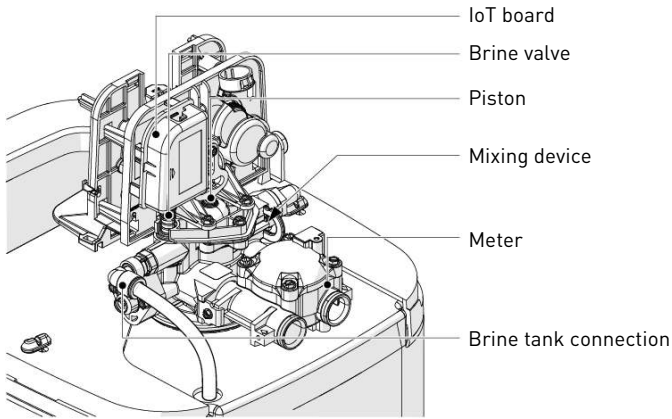

3.5 Softener's available options

3.5.1 Mixing device

The softener is equipped with a mixing device (1) whose function is to regulate the hardness of the water at the outlet. The mixing can be set from 0 % to 50 % of hard water (i.e. 0 turn = 0 % of hard water with 100 % of treated water and 1-½ turn = 50 % of hard water with 50 % of treated water).

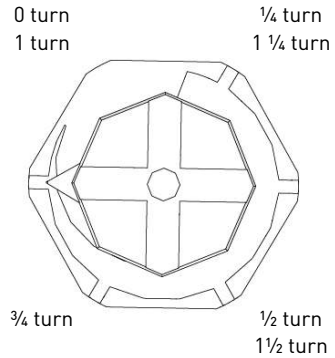
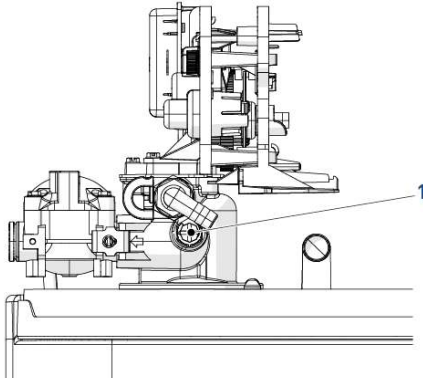

3.6 Accessories included

The following accessories are delivered with the Foleo:

- voltage transformer: 100-240 VAC to 12 VDC;
- by-pass.

4 Installation

4.1 Warnings

CAUTION



Do not lay down or flip over the softener at any time. The media may paste to the upper distributor thus obstructing its slots and may therefore compromise the softener operation.

Softener must be protected against freezing, which can cause cracking of the softener and water leakage.

4.2 Safety notices for installation

- Observe all warnings that appear in this manual;
- only qualified and professional personnel are authorized to carry out installation work.

4.3 Installation environment

4.3.1 General

- Use only regenerant salts designed for water softening. Do not use ice melt, block, or rock salts;
- keep the media tank in an upright position. Do not turn on its side, upside down, or drop it. Turning the tank upside down may cause media to enter the valve or might clog the upper screen;
- follow State and local codes for water testing. Do not use water that is micro-biologically unsafe or of unknown quality;
- when filling the media tank with water, first place the valve in the backwash position, then partly open the manual valve. Fill the tank slowly to prevent media from exiting the tank;
- when installing the water connection (bypass or manifold), first connect to the plumbing system. Allow heated parts to cool and cemented parts to set before installing any plastic parts. Do not get primer or solvent on O-rings, nuts, or the valve.

4.3.2 Water

CAUTION



Do not treat water over 43 °C, hot water would damage the softener and void warranty.

- If you are on a private well system, check minimum water pressure with an accurate gauge (gauges on older water systems are often inaccurate). Static pressure that is less than 2 bar may cause low flow rate and inadequate regeneration, depending by the pressure drop of the system as a minimum of 1.38 bar dynamic pressure is required for the valve's injector to operate effectively.

Mandatory



Do not exceed a maximum of 8.6 bar inlet pressure. Should this happen or be subject to happen, it is necessary to install a pressure regulator upstream the system.

4.3.3 Electrical

There are no user-serviceable parts in the transformer, motor, or controller. In the event of a failure, these should be replaced.

- All electrical connections must be completed according to local codes;
- make sure power source matches the rating on the unit;
- use only the 12 VDC power supply transformer that is supplied.

Mandatory



Plug the supplied transformer in an AC 100-240 V, 50/60 Hz power supply. The use of any other power supply than the one supplied void the warranty of all electronic parts of the valve.

Mandatory



**The unit must be plugged into an outlet.
Make certain the electrical supply cannot be turned off accidentally and is not controlled by a wall switch.**

CAUTION



Due to some house using piping as a source of electrical grounding, a grounding strap must be installed when required.

Electrical components are not waterproof.

- The power outlet must be grounded;
- to disconnect power, unplug the AC cable from its power source;
- do not use any extension cord;
- locate cord where it cannot be accidentally unplugged or cause any bodily harm.

4.3.4 Mechanical

CAUTION



**Do not over-tighten the pipe to piping boss.
Do not put excessive force on the inlet, outlet or drain connections of the valve.**

Prohibition



Use of silicone or petroleum-based lubricants, oils or hydrocarbon-based lubricants, is strictly prohibited with Foleo 5800 XTRi as the valve 5800 is equipped with silicone o-rings that are not compatible with silicone based lubricant.

Caution - material



Risk of damage due to wrong lubricant use

Do not use petroleum-based lubricants such as Vaseline, oils, or hydrocarbon-based lubricants.

Do not use silicon grease.

Use only P-80[®] Emulsion lubricant (water-based lubricant)!

- All plastic connections should be hand-tightened. PTFE (plumber's tape) may be used on connections that do not use an O-ring seal. Do not use pliers or pipe wrenches;
- existing plumbing should be in a good shape and free from limescale. In case of doubt, it is preferable to replace it;
- all plumbing must be completed according to local codes and installed without tension or bending stresses;
- soldering near the drain line should be done before connecting the drain line to the valve. Excessive heat will cause interior damage to the valve;
- do not use lead-based solder for sweat solder connections;
- observe the drain line requirements: maximum 1 m high at 2 bars inlet pressure. Add 50 cm for additional 1 bar at the softener's inlet;
- the valve is designed for minor plumbing misalignments. Do not support the weight of the system on the valve fittings, plumbing, or the bypass;
- it is not recommended to use sealants on the threads. Use PTFE (plumber's tape) on the threads of the 25.4 mm (1") NPT elbow, the drain line connections, and other NPT/BSP threads.

4.4 Integration constraints

Location of a water treatment system is important. The following conditions are required.

CAUTION



The surface for installation (platform or floor) must be solid, flat and level.

Mandatory



Drain must be capable of handling a backwash flow rate of 19 l/min.

- Locate the softener as close as possible from drain discharge point and within 12.2 m maximum of drain discharge point, respecting minimum drain line diameter advises given at chapter Drain line connection [→Page 34];
- room to access equipment for maintenance and adding brine (salt) to tank;
- constant electrical supply to operate the controller;
- total minimum pipe run to water heater of 3 m to prevent backup of HW into system;
- always install check valve before water heater to protect the softener from HW return;
- local drain for discharge as close as possible;
- water line connections with shut off or bypass valves;
- must meet any local and state codes for site of installation;
- use flexible piping to connect main piping to softener;
- be sure all soldered pipes are fully cooled before attaching plastic valve to the plumbing.

4.5 Softener connection to piping

Tip



To prevent your softener from incoming sediment and iron particles, Pentair recommends the installation of a 100 µm pre-filter upstream the unit.

Mandatory



The unit should be installed in accordance with the manufacturer's recommendations and meet all applicable plumbing codes.

4.5.1 Block diagram

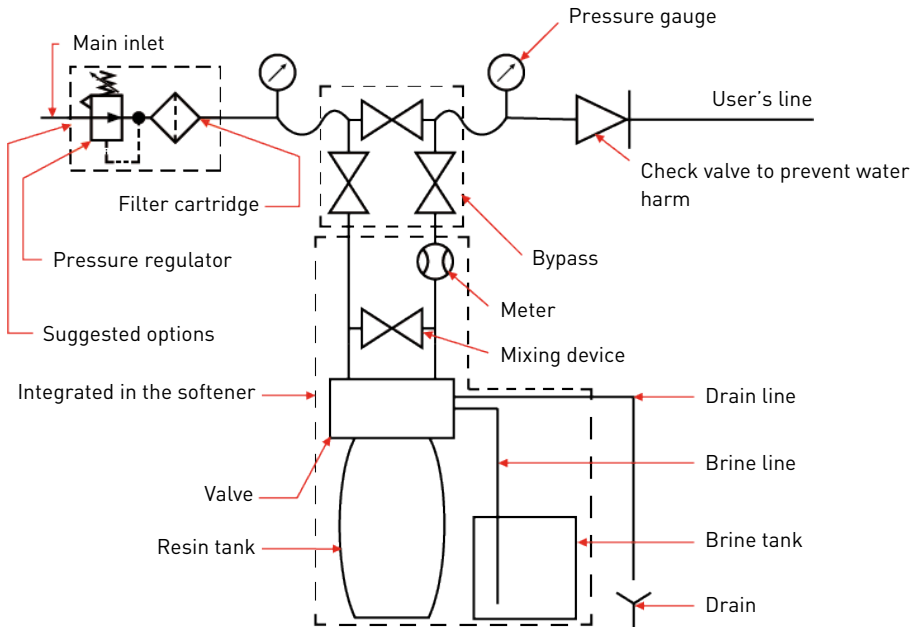

4.5.2 Installation layout

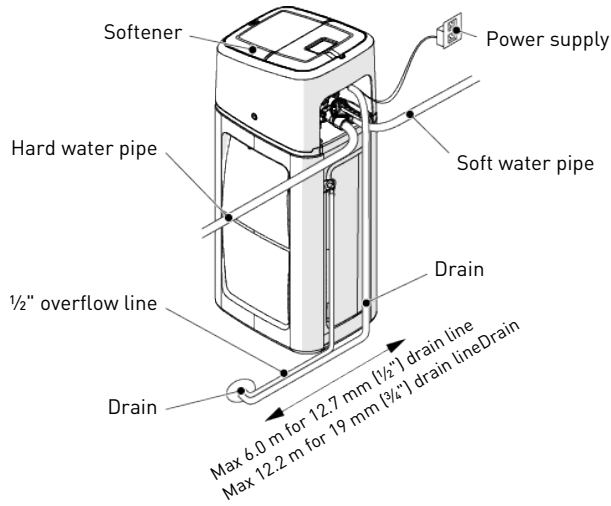

4.5.3 Tools and material required for installation

Info



Not all listed tools may be necessary for installation. Read installation procedures before starting to determine if additional tools are necessary.

Valves, grounding straps, wire, clamps and wall pipes are not supplied with the water softener.

Tip



Use ball or globe valves.

Tools:

- pipe wrenches;
- screw drivers;
- safety glasses;
- safety shoes;
- measuring tape;
- level;
- file;
- utility knife or tube cutter.

Materials:

- softener;

- pipes;
- Teflon[®] tape;
- grounding straps (optional);
- overflow pipe ½";
- valve drain pipe ½".

Material included:

- voltage transformer: 100-240 VAC to 12 VDC;
- by-pass.

4.5.4 Inspection/preliminary assembly

4.5.4.1 Inspection

Mandatory



Any missing or faulty equipment must be specified on the transport documents. Notify the transporter company and supplier immediately.

Info



In some case, some damage can only be observed [when commissioning the softener.]

Check that all delivered equipment corresponds to the shipping list and that it is not damaged.

4.5.4.2 Preliminary installation

Info



This softener doesn't need any preliminary assembly.

4.5.5 Softener installation

1. Shut off power or fuel supply to water heater, see manufacturer's instructions.
2. Shut off all water at main supply water line.
3. Open highest and lowest faucet of the line where softener will be installed to relieve pressure and drain the system.
4. Set the unit in place, see Softener connection to piping [[->Page 28](#)] and Installation layout [[->Page 29](#)].
5. Place the softener in a firm concrete floor or slab base. Be sure the unit is reasonably level.

CAUTION



Do not shim the softener directly for levelling. If necessary to shim, fabricate a platform base to set the tank on and then shim under the platform base.

6. Make necessary piping changes for connecting the softener inlet and outlet to the home piping. Make sure not to reverse inlet and outlet.
7. Installation of supplied bypass is highly recommended, see Bypassing [[->Page 33](#)].

8. Connect the inlet and outlet piping, see Water supply line [→Page 31].

Info



The softener connection threads are 1" BSPT female.

Mandatory



Make sure having the incoming water connected to the right side (looking from the front of the softener).

Mandatory



Do not use pipe joint compound or plumber's putty on the valve body threads and do not over-tighten fitting.

Use only Teflon® tape.

9. Make certain proper piping alignment is maintained. Do not apply heat to any fitting connected to the softener or damage to the valve may occur.

10. Move the softener in position and level.

Tip



To prevent water leaks, connections to the softener must be straight when the softener is levelled.

11. Carefully connect the valve drain line at the back of the softener, see Drain line connection [→Page 34].

12. Connect salt storage tank overflow elbow to drain, see Overflow line connection [→Page 35].

CAUTION



Do not connect valve drain line and overflow drain line together by teeing.

4.5.6 Water supply line and bypass connections

4.5.6.1 Water supply line

The connections should be hand tightened using PTFE (plumber's tape) on the threads if using the threaded connection type.

In case of heat welding (metal type connection), the connections should not be made to the valve when soldering.

Info



See chapter Description and component location [→Page 23] to identify the connections.

When pressurized, any composite tank will expand both vertically and circumferential. In order to compensate the vertical expansion, the piping connections to the valve must be flexible enough to avoid overstress on the valve and tank.

In addition, the valve and tank should not be supporting any part of the piping weight. This is hence compulsory to have the piping fixed to a rigid structure (e.g. frame, skid, wall...) so that the weight of it is not applying any stress on the valve and tank.

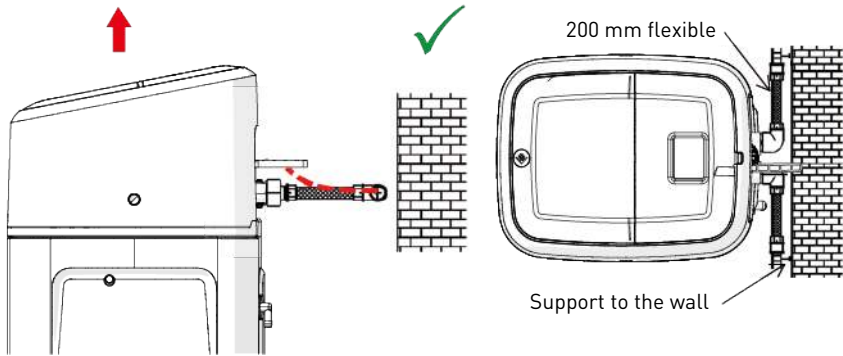

- The diagrams above illustrate how the flexible piping connection should be mounted;
- in order to adequately compensate the tank elongation, the flexible tubes must be installed **horizontally**;
- should the flexible piping connection be installed in vertical position, instead of compensating the elongation, it will create additional stresses on the valve & tank assembly. Therefore, this is to be avoided;
- the flexible piping connection must also be installed stretched, avoiding excessive length. For instance 20 - 40 cm is enough;
- excessively long and non-stretched flexible piping connection will create stresses on the valve and tank assembly when the system is pressurized, as illustrated in the below picture: on the left the assembly when the system is unpressurised, on the right the flexible piping connection when put under pressure tends to lift up the valve when stretching up. This configuration is even more dramatic when using semi-flexible piping;
- failure to provide enough vertical compensation may lead to different kinds of damage, either on the valve thread which is connected to the tank, or on the female thread connection of the tank. In some cases, damage may also be seen on the valve inlet and outlet connections;

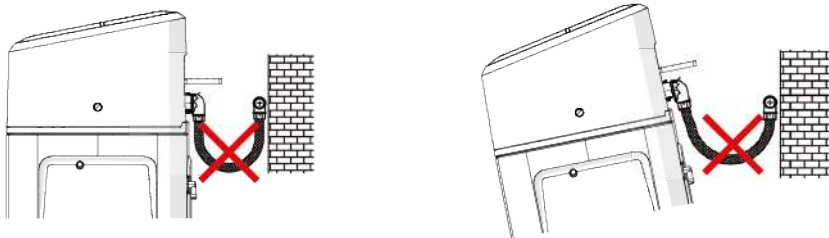

- in any case, any failure caused by improper installations and/or piping connections may void the warranty of Pentair products;

- in the same way, using lubricant* on the valve thread is not allowed and will void the warranty for the valve and tank. Indeed, using lubricant there will cause the valve to be over-torqued, which may lead to valve thread or tank thread damage even if the connection to piping has been done following the above procedure.

*Note: do not use petroleum or hydrocarbon-based lubricants. Using these types of lubricants will structurally damage valve and cause failures. Use only 100 % silicone lubricants.

4.5.6.2 Bypassing

A bypass valve system should be installed on all water conditioning systems. Bypass valves isolate the softener from the water system and allow unconditioned water to be used. Service or routine maintenance procedures may also require that the system is bypassed.

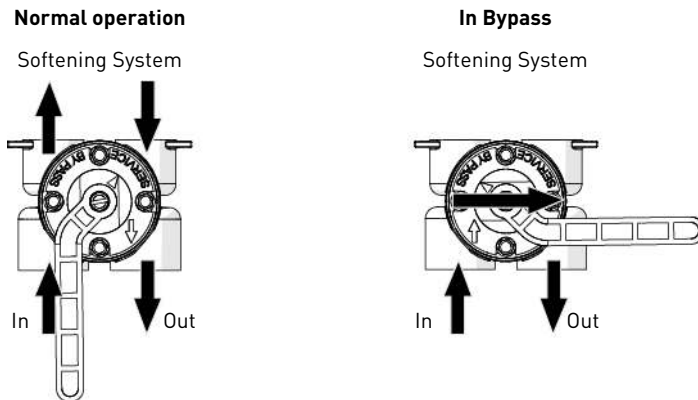

Caution - material



Risk of damage due to bad mounting!

Do not solder pipes with lead-based solder.

Do not use tools to tighten plastic fittings. Over time, stress may break the connections.

Do not use petroleum grease on gaskets when connecting bypass plumbing. Do not use silicon grease. Use only P-80® Emulsion lubricant (water based lubricant). Using another lubricant may damage the valve.



CAUTION



Do not solder pipes with lead-based solder.

Do not use tools to tighten plastic fittings.

Over time, stress may break the connections.

Prohibition



Use of silicone or petroleum-based lubricants, oils or hydrocarbon-based lubricants, is strictly prohibited with Foleo 5800 XTRi as the valve 5800 is equipped with silicone o-rings that are not compatible with silicone based lubricant.

Mandatory

Use only P-80® Emulsion lubricant (water based lubricant).

Using another lubricant may damage the valve.

4.5.7 Drain line connection
Info

Standard commercial practices are expressed here.

Local codes may require changes to the following suggestions.

Check with local authorities before installing a system.

Caution - material

Risk of damage due to over-force!

The drain line plastic elbow must always be hand-tighten without using the elbow as a lever.

The drain plastic elbow is not designed to support the weight of the tube. The tube has to have its own support.

Do not over tighten the hose tightening ring on its plastic support.

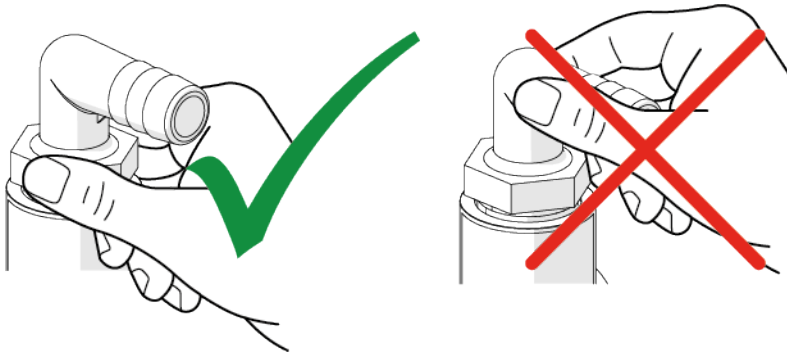

The drain line may be elevated up to 1.8 m providing the run does not exceed 4.6 m and water pressure at the softener is not less than 2.76 bar. Elevation can increase by 61 cm for each additional 0.69 bar of water pressure at the drain connector.

Where the drain line is elevated but empties into a drain below the level of the valve, form a 18 cm loop at the far end of the line so that the bottom of the loop is level with the drain line connection. This will provide an adequate siphon trap.

Where the drain empties into an overhead sewer line, a sink-type trap must be used.

Secure the end of the drain line to prevent it from moving.

Mandatory



Waste connections or the drain outlet shall be designed and constructed to provide connection to the sanitary waste system through an air-gap of 2 pipe diameters or 25.4 mm (1"), whichever is larger.

Caution - material

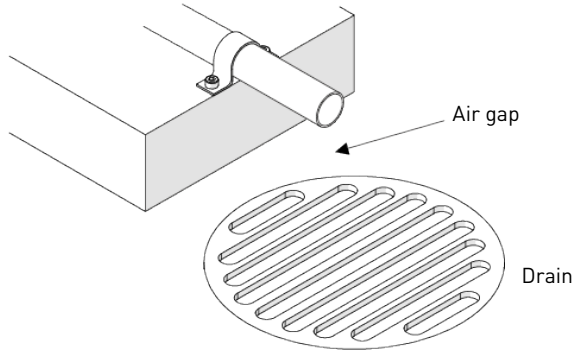

Risk of damage due to lack of gap!

Never insert the drain line directly into a drain, sewer line or trap. Always allow an air gap between the drain line and the waste water to prevent the possibility of sewage being back-siphoned into the softener.



4.5.8 Overflow line connection

In the event of a malfunction, the brine tank overflow fitting will direct "overflow" to the drain instead of spilling on the floor. This fitting is at the back of the cabinet.

To connect the overflow line, locate the barbed elbow at the back of the cabinet and connect a 1/2" tubing (not supplied) from the elbow to the drain.

Do not elevate overflow higher than overflow fitting.

Do not tie into drain line of softener. Overflow line must be a direct, separate line from overflow fitting to drain, sewer or tub. Allow an air gap as per drain line instructions.

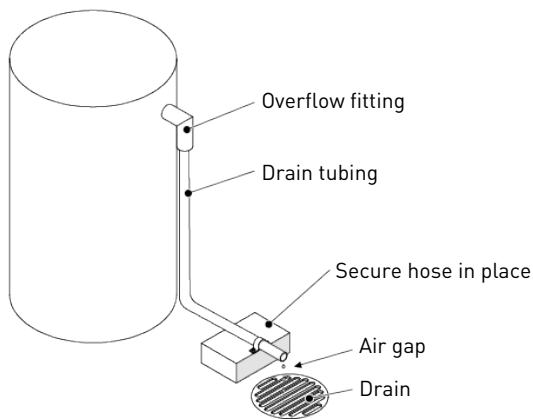

Caution - material



Risk of flooding due to lack of floor drain!

Floor drain is always recommended to avoid flooding in case of overflow.

4.6 Electrical connection

4.6.1 XTRi controller connection

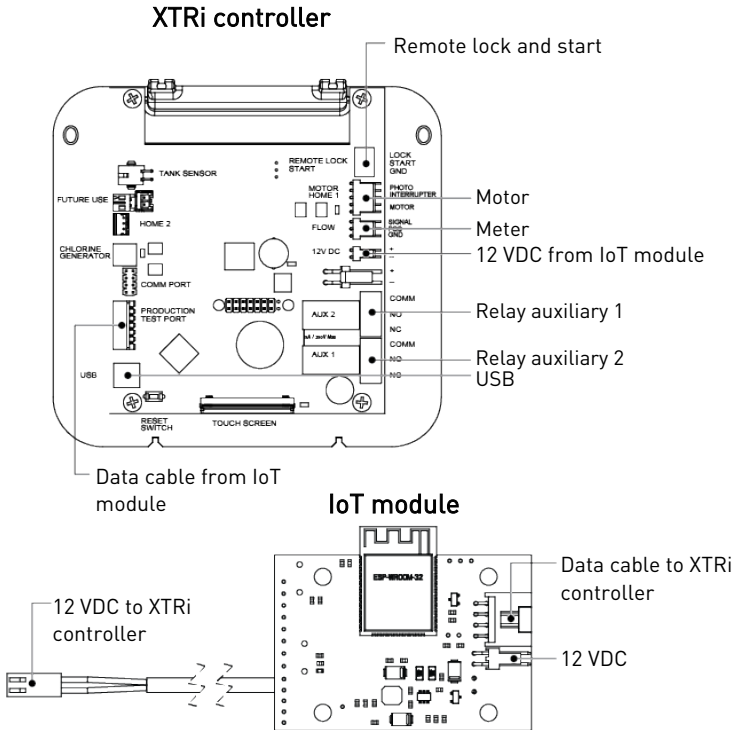

5 Programming

5.1 Home screen & commands

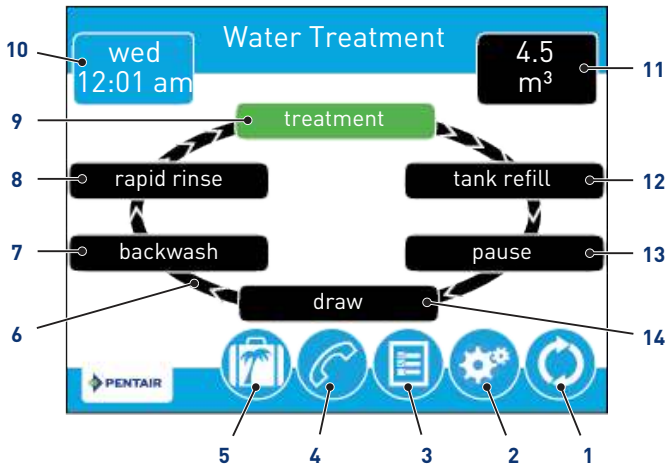





Info



If no button is pushed for five minutes, the screen will enter a power save mode. The unit will continue to operate, but the screen will be blank. Touch anywhere on the screen to exit power save mode.

Not all buttons appear on all screens.

- | | | |
|---|---|--|
| 1 |  | <p>Regeneration</p> <ul style="list-style-type: none"> Displays the regeneration screen, which allows you to start a regeneration and manually cycle through the regeneration steps. |
| 2 |  | <p>Settings</p> <ul style="list-style-type: none"> Displays the settings screen, which allows you to adjust commonly used settings. Pressing this button while in the settings screen provides access to the master settings screen, which allows you to fully program the valve. |
| 3 |  | <p>Diagnostics</p> <ul style="list-style-type: none"> Displays the diagnostics screen, which can assist in performing maintenance and troubleshooting performance issues with the valve. |
| 4 |  | <p>Assistance</p> <ul style="list-style-type: none"> Displays a name and phone number to call for unit service. |
| 5 |  | <p>Vacation</p> <ul style="list-style-type: none"> Halts all scheduled regenerations when pressed; press again to resume normal operation. |
| 6 | | <p>Regeneration cycle wheel</p> <ul style="list-style-type: none"> Displays the cycle steps the valve will step through during service and regeneration; the current cycle step is always shown on green. |

Info



On metered units, the "Treatment" step on the regeneration cycle wheel will flash when water is flowing through the unit.

- 7 Backwash
 - Water flows from the bottom of the vessel to the top of the vessel to clean and mix the media.
- 8 Rapid Rinse
 - Water flows from the top of the vessel to the bottom of the vessel to rinse the media.
- 9 Treatment
 - The unit is treating water.
- 10 Day and time
 - Displays the currently programmed day of the week and time. This button will flash at the start-up and if the supercapacitor is discharged
- 11 Next scheduled regeneration
 - Displays the time to next scheduled regeneration, or volume remaining until regeneration in meter systems.
- 12 Tank Refill
 - Brine tank is refilled with water.
- 13 Pause
 - Valve comes back in service position to allow brine preparation after refill. Shown if variable refill/brining regeneration flow has been selected in master setting.
- 14 Draw
 - Brine is drawn into the media and then slowly rinsed out.
- Custom
 - Shown if custom regeneration flow has been selected in master setting.
- Home
 - Displays the home screen.
- Arrows
 - Displayed in the upper-left and upper-right corners of the screen, these arrows allow you to navigate from one screen to another.
 - Allow you to change the values of certain settings when programming the controller.

Info



Settings on previous screen are not saved unless is pressed.



Alarm

- Displayed when an error has occurred; accompanied with an audible alarm. Press to silence the audible alarm.



Error

- Displayed when an error has occurred. Press to display the error screen for more detailed error information.



Error log

- Press to show error list with date and time.



Advance

- This arrow allows you to advance through cycle steps during a regeneration.



Reset

- Displayed in the diagnostics screen by pushing on totalizer and peak flow buttons to reset totalizer and peak flow data, and in master settings screen to reset parameters to factory or non-factory settings.



Non-factory settings

- Press to save all the configuration in a custom profile.



Brightness/sound

- Displays the Brightness/Sound screen, to adjust the backlight of the control screen and to mute the alarms of the control.



Accept

- Press to save or accept changes in controller configuration.



Cancel

- Press to cancel configuration and exit to previous screen without saving.

The buttons below are only available for XTRi controller.



Alert

- Will display when there is no internet connection.



WiFi

- Represents signal strength to WiFi router.



Bluetooth

- When displayed in black, bluetooth signal is open. When displayed in white, bluetooth connection is engaged.

5.2 Quick program guide

Info



Some items may not be shown depending on controller configuration.

Info



The controller will discard any changes and exit master settings if any button is not pressed for five minutes.

Screen name	Parameters	Values	Notes
Format, Format	Language	English French German Italian Spanish Dutch Portuguese	Changes the language to display screen text and button labels.
	Units	Metric	All programmed units and values are recalculated after adjusting this setting.
	Hardness units	mg/L or ppm German degrees French degrees Clark degrees	Changes hardness units used in displaying hardness parameters and calculating system capacity and editing exchange capacity and hardness settings.
Format, Assistance name	Free-form text	A - Z and space	Name of service provider to display when viewing the assistance screen. 24 character limit.
Format, Assistance phone	Free-form text	0 - 9 and space	Phone number of service provider to display when viewing the assistance screen. 14 character limit.
Format, Assistance interval	Interval	Month based: 1 - 60 Regen based: 5 - 2000 OFF	Set to automatically display the assistance screen after a certain number of months or regenerations.

Screen name	Parameters	Values	Notes
Valve	System	4	Type 4 (single system) is currently the only available selection.
	Valve	5800	
	Regen type	Softener delayed	Regeneration type is described in detail on Variable Refill/Brining regeneration cycle [5-cycles operation] [->Page 17].
	Media volume	10, 15, 20 or 28 L	Respectively for Foleo 10, Foleo 15, Foleo 20 and Foleo 30.
	Salt dosage	80 g/L	Programmable up to 200.
	BLFC size	0.125 – 0.25 gpm	0.125 for Foleo 10 and Foleo 15. 0.250 for Foleo 20 and Foleo 30.
	Capacity	g/L CaCO ₃ or °Hm ³	Only required on softener metered systems to calculate treated water capacity and reserve. Represents total system capacity between regenerations.
	Hardness		Calculates treated water capacity and reserve. Represents hardness of untreated water.
	Calendar override regeneration	Off - 1 - 99 days	Report to local regulation.
	Regeneration time	HH:MM	Set at a time of no or low water usage.
	Reserve	Fixed reserve 30%	Only available when softener meter delayed regeneration type is selected. Selecting fixed % or fixed volume will display additional configuration options.
Regeneration	Regeneration flow	Variable refill/brining	Cycle steps on the home screen and during regeneration will change to reflect the cycle steps and order. Variable refill/brining calculates refill time based on salt dosage, media volume, and BLFC Size, and it is not possible to change it.
Relay output	Aux.1/Aux.2	Off	
Meter	Meter type	0.75" Paddle	
	Emergency regeneration	Off	
	Continuous flow detect	Off	Gives an alarm if continuous flow is detected at the outlet.

Screen name	Parameters	Values	Notes
Setting review	Displays a summary of all programmed settings.		
Water Saver Regen	Water saver regen.	Off	
Remote regeneration	Remote signal duration	Off	
Cl generation* Low salt	Cl generation / Low salt	Off	Chlorine generation together with low salt detection will be performed during brine draw cycle.
	Regen interval	1 – 255 Regeneration	This parameter determines the regeneration frequency on which there will be chlorine generation. If you don't have the chlorinator, please check that this parameter is set as "Off".

* This option is not available on Foleo produced after 2022.

Programming factory parameters

	Foleo 10	Foleo 15	Foleo 20	Foleo 30
Format				
Language	English	English	English	English
Units	Metric	Metric	Metric	Metric
Assistance Interval	Month based	Month based	Month based	Month based
Interval Value	24	24	24	24
Hardness units	mg/l	mg/l	mg/l	mg/l
Set control Time	Off	Off	Off	Off
24h format	Off	Off	Off	Off
Non-Factory	Off	Off	Off	Off
Valve				
Regen Type	Softener meter delayed	Softener meter delayed	Softener meter delayed	Softener meter delayed
Regen flow	Variable refill/brining	Variable refill/brining	Variable refill/brining	Variable refill/brining
Meter Type	0.75" Paddle	0.75" Paddle	0.75" Paddle	0.75" Paddle
Valve	5800	5800	5800	5800
Day override/ time-driven	Off	Off	Off	Off
Regen. Time	02:00	02:00	02:00	02:00
Continous flow detect	Off	Off	Off	Off

	Foleo 10	Foleo 15	Foleo 20	Foleo 30
Regeneration				
Media Volume [l]	10	15	20	28
Salt Dosage [g/l]	80	80	80	80
BLFC size [gpm]	0.125	0.125	0.25	0.25
Hardness [mg/l]	300	300	300	300
Capacity [grams]	406	609	812	1137
Reserve	fixed %	fixed %	fixed %	fixed %
Reserve %	30	30	30	30
Remote Signal duration	1	1	1	1
Step #1 tank refill	5	8	5	7
Step #2 pause	120	120	120	120
Step #3 draw	46	69	67	94
Step #4 backwash	4	4	5	6
Step #5 rapid rinse	4	4	5	6
Relay Out put				
Auxiliary 1	Off	Off	Off	Off
Auxiliary 2	Off	Off	Off	Off
SelClGen	0	0	0	0

5.3 Touchscreen controller quick start

Info



Press  on any quick start screen to reset the screen back to its default settings, excepted on the "Assistance interval" screen.

Steps Assistance name screen [[→Page 44](#)] and Assistance phone screen [[→Page 45](#)] are optional and are not required to start the system. All controller settings may be changed after the unit is in service.

If the screen is blank after plugging in the unit, touch the screen to turn the screen on.

5.3.1 Format screen

After plugging in the unit for the first time, the format screen is displayed.

Info



Happens until Assistance Name is set.

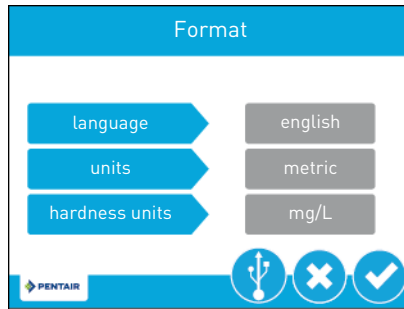

Press the **language** button and use the arrows to adjust the system's displayed language: English, French, German, Italian, Spanish, Dutch or Portuguese.

Press the **units** button and use the arrows to adjust the system's units of measure (either U.S. or metric).

Press the **hardness units** button and use the arrows to adjust the system's hardness units of measure (grains per gallon, mg/L or ppm, German degrees, French degrees, or Clark degrees). Hardness units are adjustable only if metric units are selected.

Press to validate the selection and move to the assistance name screen.

5.3.2 Assistance name screen



Using the keypad, type the name of the water treatment professional or company that the homeowner may call for system service (optional).

To enter a letter using the keypad, quickly press the keypad button the number of times that correspond with the position of the correct letter on the button. For example, to enter the letter "c", quickly press the **abc** button three times.

Press to validate the selection and move to the assistance phone screen.

5.3.3 Assistance phone screen





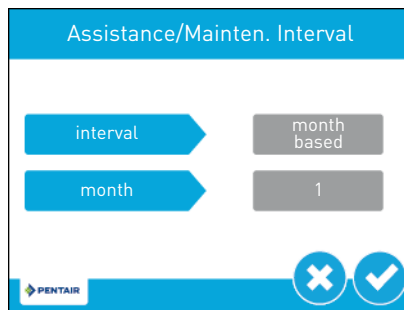

Enter the phone number of the water treatment professional or company that the homeowner may call for system service (optional).

Press  to validate the selection and move to the assistance interval screen.

5.3.4 Assistance interval screen



Use the assistance interval screen to set the interval in which the homeowner will need to call a water treatment professional or company for system service (optional). The assistance interval can be based on a set number of months (month based) or a number of regenerations (regen based).

Press the **interval** button and use the arrows   to select a month-based or regen-based assistance interval. Press either the **month** or **regen.** button (depending on your previous selection), and use the arrows   to select the number of months (up to 60) or regenerations (up to 2000) until the homeowner will need to call for service.

Press  to validate the selection and move to the home screen.

Info



Once the interval is elapsed and the maintenance has been done, this interval must be set again to the desired interval which will remove the maintenance icon at the same time.

5.3.5 Day and time screen

On the home screen, the flashing **Day and Time** button indicates that the day of the week and time need to be set. If the date and time are incorrect, press the **Day and Time** button to update to the correct day and time.

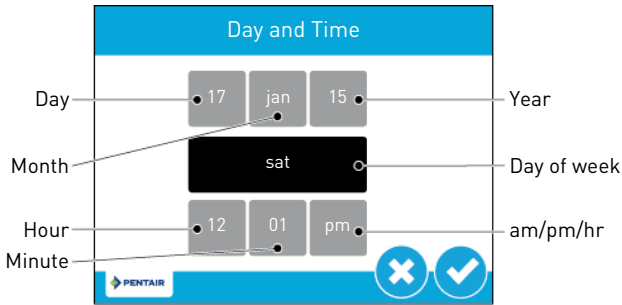

Press the **Hour**, **Minute**, and **am/pm/hr** buttons and use the arrows to adjust the values to the correct time. Setting the value of the **am/pm/hr** button to **hr** changes the display to a 24 hour clock.

Press the **Day**, **Month**, and **Year** buttons and use the arrows to adjust the values to the correct date. **Day of week** will be automatically set with the date.

Press to validate and to return to the home screen, or to exit without saving.

5.3.6 User assistance screen

The assistance screen displays the name and phone number that the homeowner may call for service of the unit.

From the master settings or home screens, press the assistance button to access the user assistance screen.



Info



If no assistance name and phone as been set, "for service or assistance: please contact your local water professional" will be displayed.

The Assistance screen is also displayed automatically when the system reaches the programmed assistance interval.

5.3.7 Settings screen

The settings screen allows you to change basic controller settings including time of regeneration and water hardness. These settings improve the operational efficiency of the system and can be adjusted independently from other controller settings without needing to enter master settings.

Info



Settings can not be accessed during a regeneration. If a regeneration has to start while in the settings menu, it will not start until exit the menu.

From the home screen, press the settings button to access the settings screen.

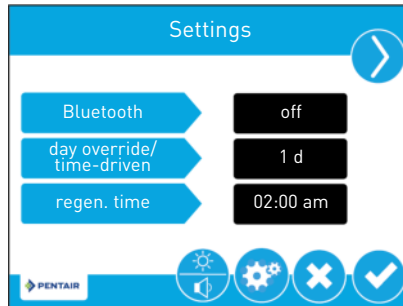

Bluetooth: Turns ON the bluetooth signal when you need to connect to WIFI. It will automatically turn to OFF when WiFi is connected.

Press **day override/time-driven** and use the arrows to adjust the number of days since last regeneration in which a new regeneration will automatically be run whether one is scheduled or not.

Press **regen. time** and use the arrows to adjust the time of day when an automatic regeneration cycle will begin.

Press and to switch screens.

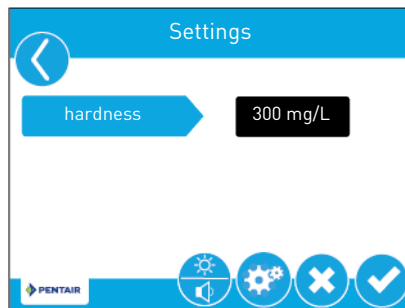

Press **hardness** and use the arrows to adjust the hardness setting. This value should match the hardness of the incoming untreated water supply.

Info



If immediate volumetric regeneration has been set, regeneration time will have no influence on it and regeneration will start as soon as capacity end.

Changing the hardness setting recalculates treatment volume and regeneration interval. This setting should only be changed on the advice of a professional.

The hardness parameter is not accessible in timeclock and filter mode.

Press to save your changes or press to return to the home screen without saving.

Additional features

Additional features may be accessed from the Settings screen by pressing the buttons at the bottom of the screen:



Master settings

- Displays the master settings screen, which allows you to fully program the valve.



Brightness/
sound:

- Displays the Brightness/Sound screen, which allows you to adjust the backlight of the control screen and allows you to mute the alarms of the control.

5.3.8 Master setting screens

The master settings screens include all configurable parameters available in the controller.

From the settings screen, press the settings button . A warning message appears:

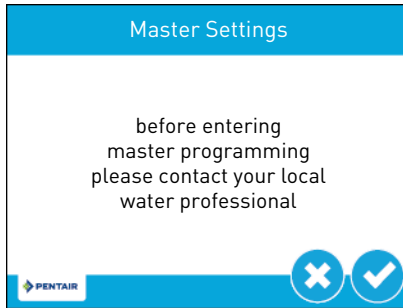

Press to continue to the password screen or press to return to the home screen.

The Password screen displays a numeric keypad:

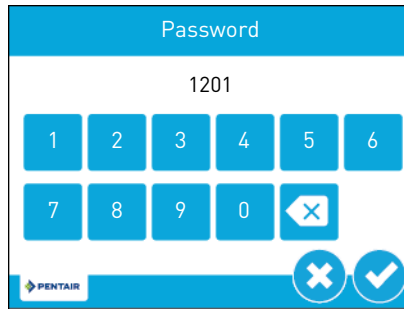

Enter the master settings password **1201** and press to continue to the master settings screen, or press to return to the home screen.

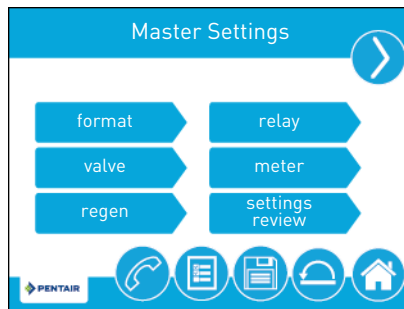

While in the master settings screens, press to save all set parameters to a custom profile (see Non-factory setting [→Page 59]) or press the home button to return to the home screen.

Features of the master settings screens are described below. See Master setting programming [→Page 50] and Format screen [→Page 50] for more detailed information.

format: Contains settings for Language, Units, Assistance Name, Assistance Phone, and Assistance Interval. See **Quick program guide** [→Page 39] for more information about these settings.

Info



Differently from what happens if the menu is acceded from the quick start, when acceded from master setting, push to exit the menu without saving the modifications.

valve: Contains settings for system, valve, and regeneration type. Plus, depending of the settings, media volume, salt dosage, BLFC size, capacity, hardness, day override, reserve, volume override and regeneration time.

regen: Contains settings for regeneration flow and cycles duration.

relay: Contains settings for Aux 1 and Aux 2 relays.

meter: Contains settings for meter types.

settings review: Displays a summary of all programmed settings.

Press the screen navigation arrow at the top right of the screen to navigate to the secondary master settings screen.

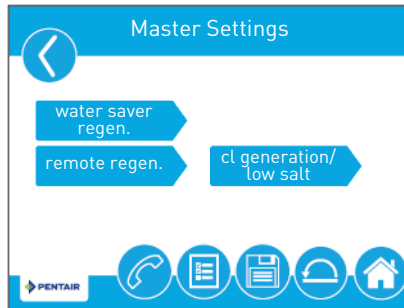

water saver regen.: Set a low water usage regeneration, see **Water Saver Regen screen** [→Page 57].

remote regen.: Contains settings for triggering a regeneration via a remote input.

cl generation/low salt*: Contains settings for chlorine generation and salt alarm.

* This option is not available on Foleo produced after 2022.

5.4 Master setting programming

Info



If a regeneration is scheduled to occur while in master settings, the scheduled regeneration will start as soon as exiting the master setting.

Due to the complexity of these settings and the potential for errors, master settings should only be accessed by your local water professional.

Caution - material



Incorrect system operating due to improper master settings adjusting !

Before entering master settings please contact your professional water dealer.

The following is a detailed overview of settings available in Master Settings. Please see Format screen [→Page 50] for the complete set of values and ranges available to program while in master settings.

5.4.1 Format screen

From the master settings screen press the **format** button to display the format screen.

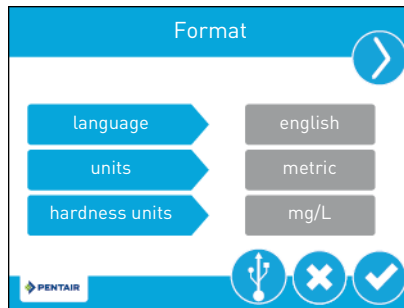

language: Displays the language used on the controller: English, French, German, Italian, Spanish, Dutch or Portuguese.

units: Contains settings for the unit type (either US or Metric) to be used in the controller.

hardness units: Contains settings for hardness units of measure (grains per gallon, mg/L or ppm, German degrees, French degrees, or Clark degrees).

Info



Hardness units are adjustable only if metric units are selected.

Degree hardness units are converted to ppm upon input. Degree inputs may be rounded up or down to the nearest ppm equivalent.

Press the screen navigation arrows at the upper-right and left of the screen to navigate to the assistance name, assistance phone, and assistance interval screens. See Quick program guide [→Page 39] for more information about these settings.

Press  to save changes or press  to return to the master setting screen without saving.

5.4.2 Valve screen

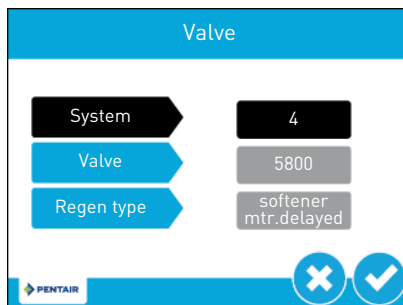

From the main master settings screen press the **valve** button to display the valve screen.



system: Displays the system type. Type 4 (single system) is currently the only available selection.

valve: Set to 5800.

regen type: Set to softener metered delayed.

Press  to save and pass to the next screen or press  to return to the master settings screen without saving.

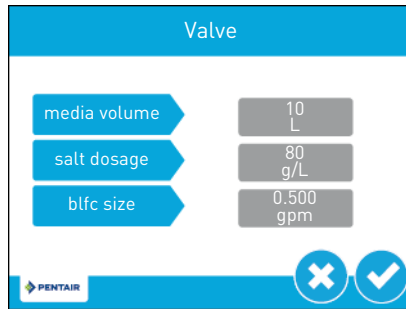

media volume: Set to 10 L, 15 L, 20 L or 28 L, respectively for Foleo 10, Foleo 15, Foleo 20 and Foleo 30.

salt dosage: Adjust the salt dosage from 80 to 200 mg/L, depending of hardness water outlet desired.

blfc size: BLFC size set to 0.500 gpm as standard. For Foleo 10 and 15 models, set to 0.125 gpm. For Foleo 20 and 30 models, set to 0.25 gpm.

Press to save and pass to the next screen or press to return to the master settings screen without saving.

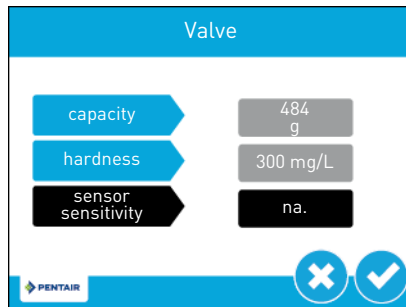

capacity: Set to 406 g as equivalent CaCO_3 , 609 g as equivalent CaCO_3 , 812 g as equivalent CaCO_3 or 1137 g as equivalent CaCO_3 , respectively for Foleo 10, Foleo 15, Foleo 20 and Foleo 30.

hardness: Set to system inlet water hardness.

sensor sensitivity: Option not available.

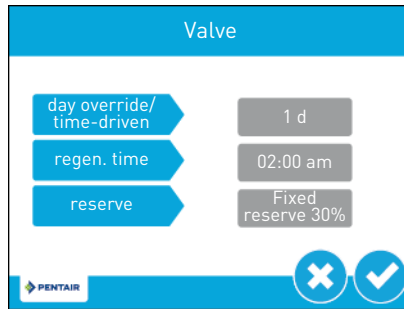

Press to save and pass to the next screen or press to return to the master settings screen without saving.



day override/time-driven: Adjust the day override regarding on local regulation.

regen. time: Adjust the regeneration time, set to low or no water usage time as much as possible.

reserve: Set to variable reserve.



Press  to save and pass to the next screen or press  to return to the master settings screen without saving.

5.4.3 Regeneration screen

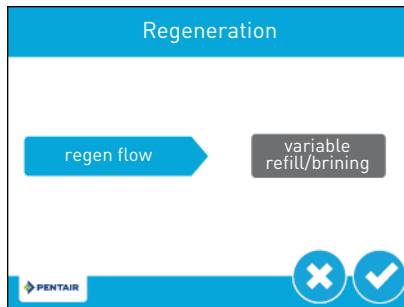
From the master settings screen press the **regen.** button to display the regeneration screen.



regen flow: Set to variable refill/brining.

Press  to save and pass to the next screen or press  to return to the master settings screen without saving.

When regeneration flow was set to a downflow option, the following warning messages appear:

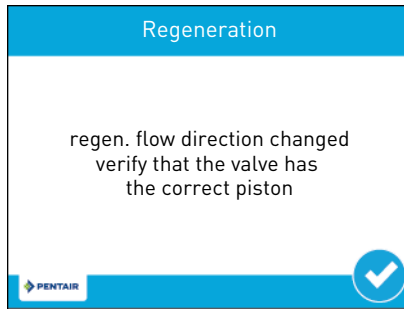

Press  pass to the next screen.

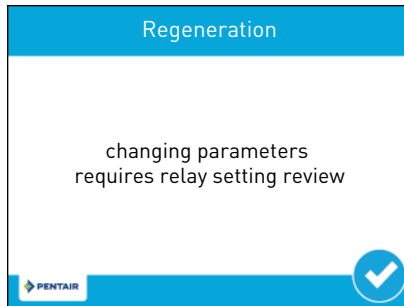

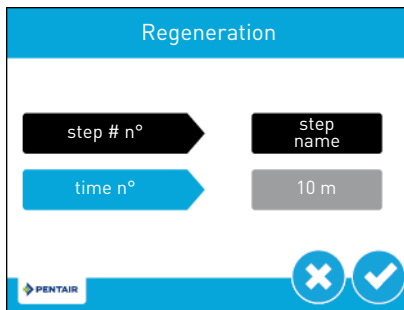

Press  pass to the next screen.



step # n°: Step name [pause, backwash, draw, rapid rinse, tank refill].

time n°: Adjust the step timing, see **Cycles times and water consumption** [[→Page 55](#)].

Press  to save and pass to the next screen or press  to return to the regeneration screen without saving.

5.4.3.1 Cycles times and water consumption

Softener	Foleo 10					Foleo 15				
Salt dosage (g/L _{resin})**	80	100	120	160	200	80	100	120	160	200
Water to dissolve the required salt quantity [L]	2.24	2.80	3.36	4.48	5.60	3.36	4.20	5.04	6.72	8.40
Brine to draw [L]	2.52	3.15	3.78	5.04	6.30	3.78	4.73	5.67	7.56	9.45
Refill*	5	6	8	10	12	8	9	11	15	18
Pause	120					120				
Brine draw*	7	8	10	13	16	10	12	15	19	24
Slow rinse	37					55				
Backwash	4					5				
Rapid rinse	4					5				
Water consumption per regen [L]*	62.9	63.9	66.0	68.6	71.2	85.0	86.5	89.1	93.2	97.4

Softener	Foleo 20					Foleo 30				
Salt dosage (g/L _{resin})**	80	100	120	160	200	80	100	120	160	200
Water to dissolve the required salt quantity [L]	4.48	5.60	6.72	8.96	11.20	6.27	7.84	9.41	12.55	15.69
Brine to draw [L]	5.04	6.30	7.56	10.08	12.60	7.06	8.82	10.59	14.12	17.65
Refill*	5	6	8	10	12	7	9	10	14	17
Pause	120					120				
Brine draw*	9	11	13	17	22	12	15	18	24	30
Slow rinse	37					51				
Backwash	4					6				
Rapid rinse	4					6				
Water consumption per regen [L]*	118.9	119.6	122.5	129.0	137.3	167.1	171.8	176.5	186.6	196.0

* for a 100% regeneration.

** choose salt dosage upon inlet hardness level and required capacity.

5.4.4 Relay output screen

From the master settings screen press the **relay** button to display the relay output screen.

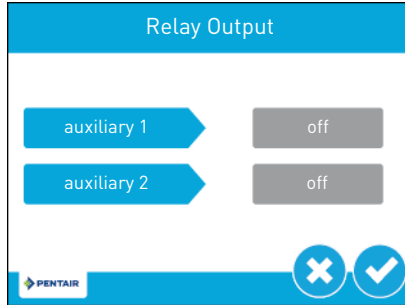

Press to save and to return to the master settings screen or press to return to the master settings screen without saving.

auxiliary 1/auxiliary 2: Set to off.

5.4.5 Meter screen

From the master settings screen press the **meter** button to display the meter screen.

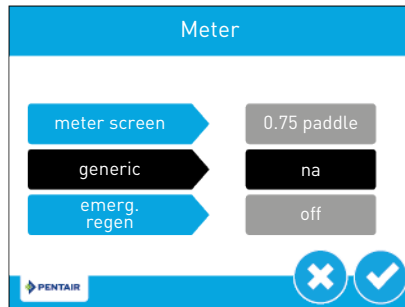



meter type: Set to 0.75" paddle.

emerg. regen.: set to off, this option would create an immediate regeneration as the capacity is depleted and exceeded by 50 %.

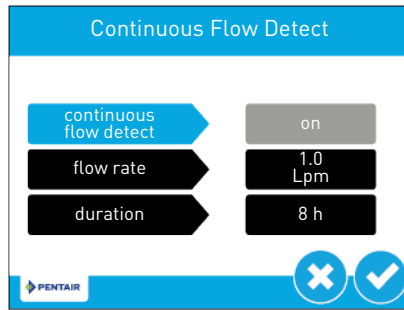
Press to save and to go to the continuous flow detect screen or press to return to the master settings screen without saving.



continuous flow detect: Set to on. Triggers an alarm when continuous flow smaller than 0.5 gpm or 1 Lpm is detected by the flow meter over a 8 hours period.

Press  to save and to return to the master settings screen or press  to return to the master settings screen without saving.

5.4.6 Settings review

From the master settings screen press the **settings review** button to display the settings review screen, which display a read-only summary of all programmed settings in the controller.

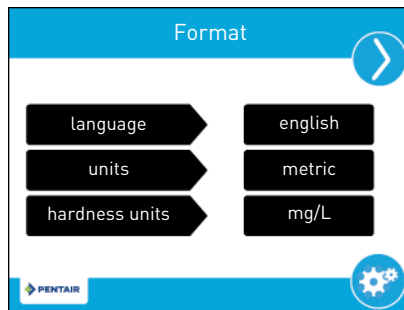

Use the navigation arrows at the top of the screen to scroll through the parameters currently set in the controller. The settings review screens are formatted similarly to the corresponding screen where each parameter was set.



Press  to return to master settings.

5.4.7 Water Saver Regen screen

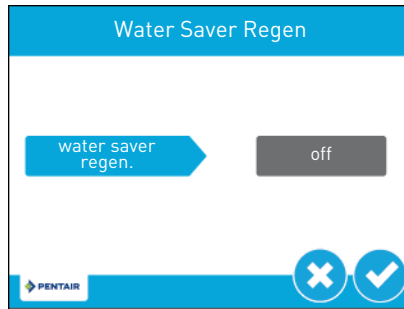
From the secondary master settings screen press the **water saver regen.** button to display the water saver regen. screen.



water saver regen.: Set to off. When activated, the backwash duration is reduced by 50 % and the fat rinse duration is reduced by 66 %, classic regeneration happening still at the programmed regeneration frequency (1-25 regenerations).



Press  to save and to return to the master settings screen or press  to return to the master settings screen without saving.

5.4.8 Remote Regeneration screen

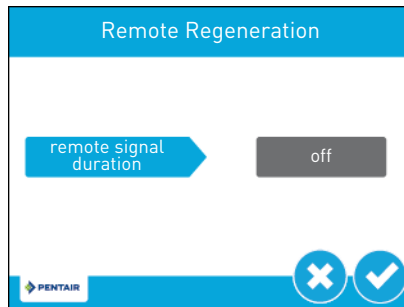
From the secondary master settings screen press the **remote regen** button to display the remote regeneration screen.



remote signal duration: Set to off.

Press  to save and to return to the master settings screen or press  to return to the master settings screen without saving.

5.4.9 Chlorine generation screen



Mandatory

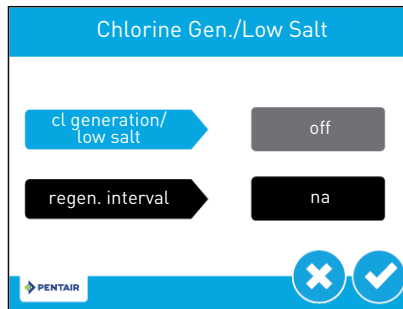

Chlorine generator must be set to off!





cl generation/low salt: If necessary, set to OFF.

Press  to save and to return to the master settings screen or press  to return to the master settings screen without saving.

5.4.10 Non-factory setting

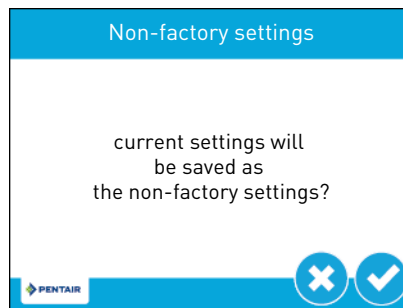
After all parameters in master setting have been set, press  on the master settings screen to display the non-factory settings screen.



Press  to save all programmed master settings parameters to non-factory settings. At any point, the controller can be reset to these saved custom settings (see Error Log [→Page 61]). Press  to return to the master settings screen without saving.

Info



By performing a custom reset, any setting that is subsequently programmed without saving to non-factory settings will be reset to the previously saved non-factory settings in the controller.

5.5 Diagnostics

The controller records and displays a variety of diagnostic data to assist with troubleshooting performance issues and fine-tuning system efficiency.

From the master settings or home screens, press the diagnostics button  to access the diagnostics screen.

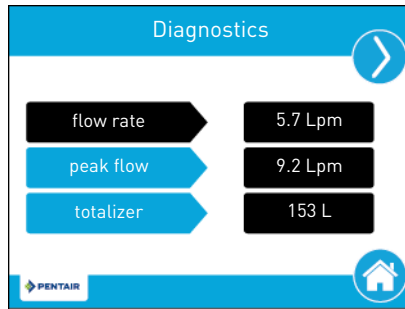

Press the screen navigation arrows at the upper-right and left of the screen to view each diagnostic parameter.

Press the home button to return to the home screen.



Info

If a regeneration is scheduled to occur while in the Diagnostic screen, the scheduled regeneration will start as soon as exit the diagnostic.

Only Peak Flow and Totalizer can be changed, they can be reset to zero by entering the parameter and then pressing .

Totalizer has a maximum value of 99 999 999. If this number is reached, the totalizer must be reset to zero to continue tracking this value.



Parameter	Description
Flow rate	Displays the current flow rate.
Peak flow	Displays maximum flow rate of water since last reset. By entering the parameter, date and time of occurrence will be displayed.
Totalizer	Displays total volume of water used since last reset.
Last Regen	Displays time occurred after last regeneration.
Reserve (only available for softener meter delayed regeneration type)	Displays the reserve volume based on the reserve type selected under master settings
Software Version	Displays the software version installed on the controller.
No. of Regens	Displays how many manually and system-initiated regenerations the system has gone through since last reset.
Regen. Interval	Displays the average length of time between regenerations based on the past four regenerations.

Parameter	Description
Daily Usage	Displays average water usage for each day of the week based on the usage on that day for the past six weeks. Enter the parameter to display average water daily usage. Select each day to display daily consumption for each day of the past six weeks together with dates. Use the arrows  and  to come back to diagnostics screen.
Usage Since Regen.	Displays water usage since last regeneration.
Last Settings Change	Displays the time occurred after the last update to master settings.
Seal Life	Not available.

5.5.1 Error log

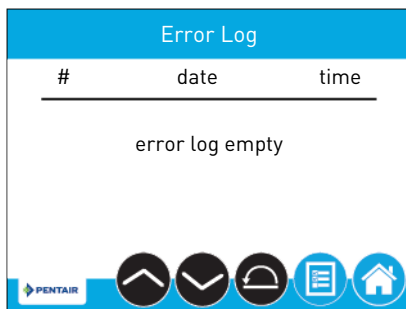
Error log screen shows the list of logging attempts with date and time. From the diagnostics screen press  to display the error log screen.



To clear all error logs, press  to activate the button, press  again to clear the list. Then enter **1201** at the password prompt screen and press  to validate.

5.6 Resetting the controller

From the master settings screen press  to display the reset screen.

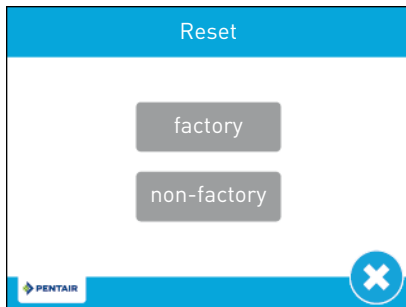

Press the **factory** button to reset all controller parameters to their factory defaults, or press the **non-factory** button to reset controller parameters to previously saved custom settings [see **Non-factory setting** [->Page 59]].

Info



Factory reset will reset the XTRi controller firmware default values; this will require the Foleo unit to be fully reprogrammed. We strongly suggest avoiding the factory reset.

Non-factory reset will reset the controller but will maintain Foleo specific settings. This type of reset is the preferred one.

A warning screen appears before parameters are reset. Press to confirm the reset or press to return to master settings.

5.7 Pentair application setup

5.7.1 Pairing the Foleo water softener with Wi-Fi Devices

The Foleo water softener can be paired with a smartphone or tablet.

End users can download and install the Pentair Pool App from the or .

WiFi connection must be 2.4 GHz.

5.7.2 Sign up

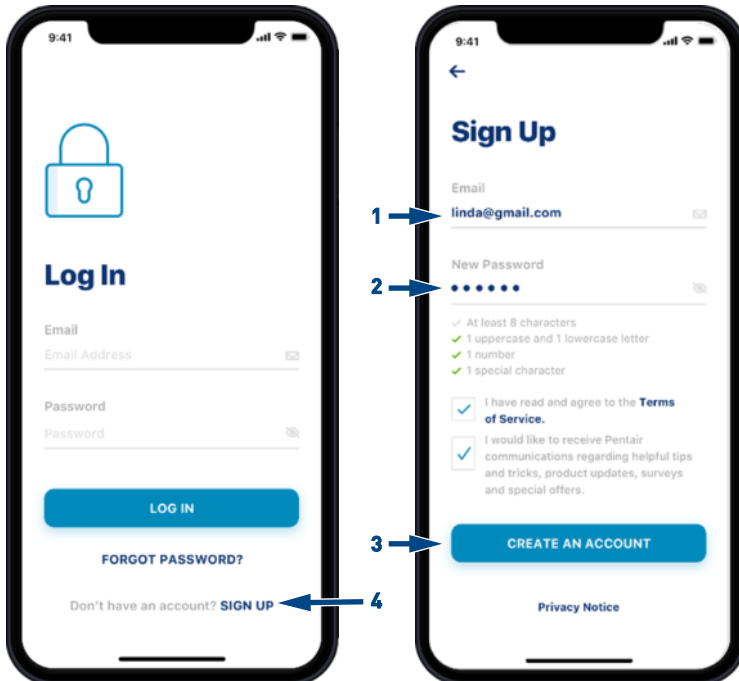

End users will need to create an account to monitor their water softeners.

1. From the Log In page, press **SIGN UP (4)** to create a new account.
 - ⇒ If you already have an account, skip to Sign in [→Page 65].
2. Add an email address (1) and set a password (2).
3. Press on **CREATE AN ACCOUNT (3)**.
 - ⇒ An email will be sent to the email box for verification.

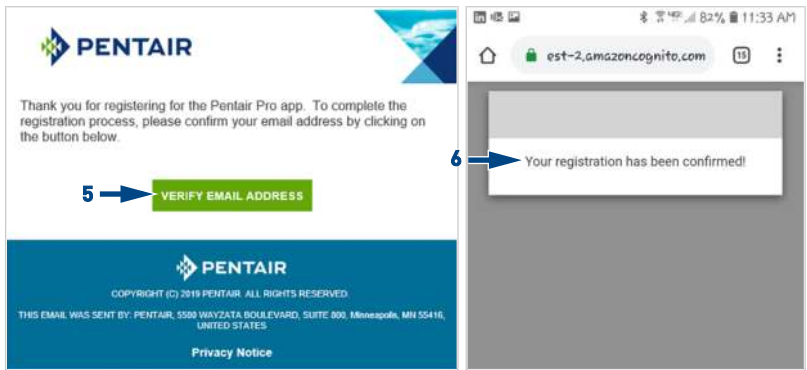

4. Open the received email and click on **VERIFY EMAIL ADDRESS (5)** to complete the process (6).

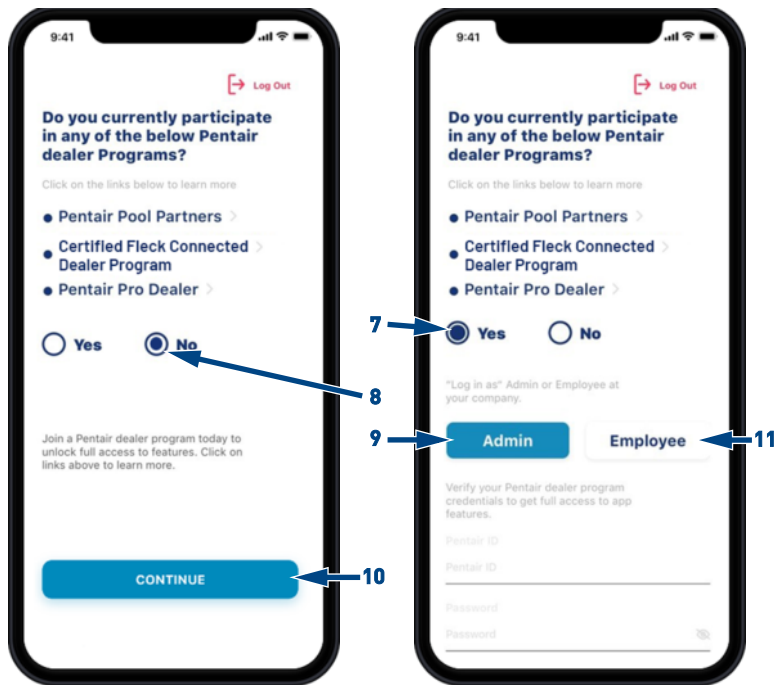

5. For Pentair Partner Center non-member, select **No (8)** and press on **CONTINUE (10)**.
 ⇒ The app goes to Sign in [→Page 65].
6. For Pentair Partner Center member, select **Yes (7)** and select **Admin (9)** or **Employee (11)**.

Info



The Admin for the partner portal must be the initial sign up for the app.

Pentair Partner Center employees will be able to be invited to be part of the Pro app team through the Pentair Pro Web App. The Pentair ID and password is the same as the Partner Center email and password.

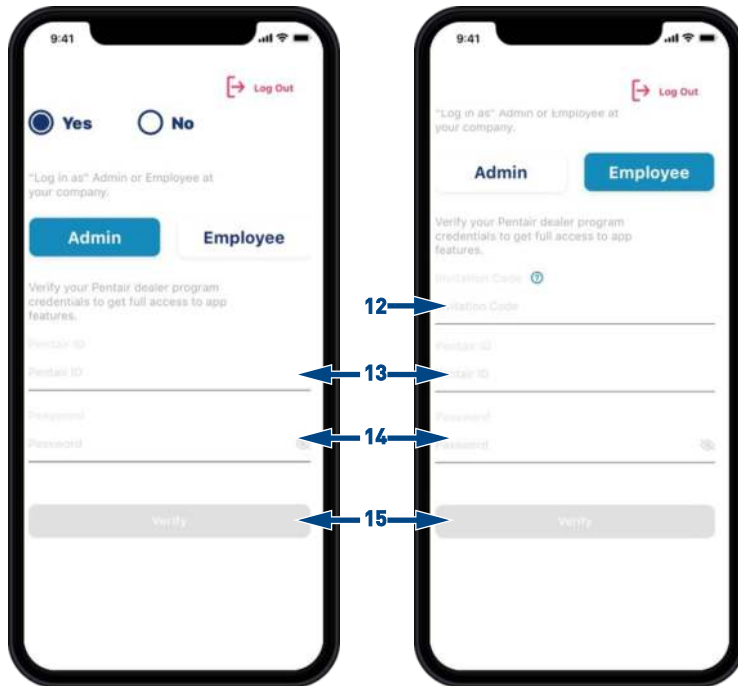

7. Only for Employee, enter the Invitation code **(12)**.
 ⇒ The invitation code is created by the administrator.
8. Enter the Pentair ID **(13)** (Pentair Centermail).
9. Enter the password **(14)**.
10. Press on **Verify (15)**.

5.7.3 Sign in

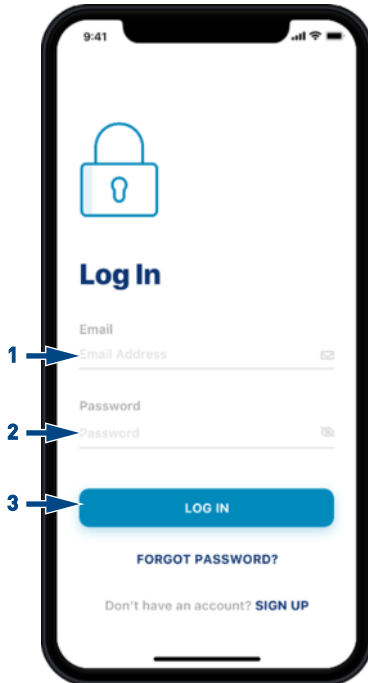

1. Enter the verified email (1) and password (2).
2. Press on **LOG IN** (3).

5.7.4 Create a profile

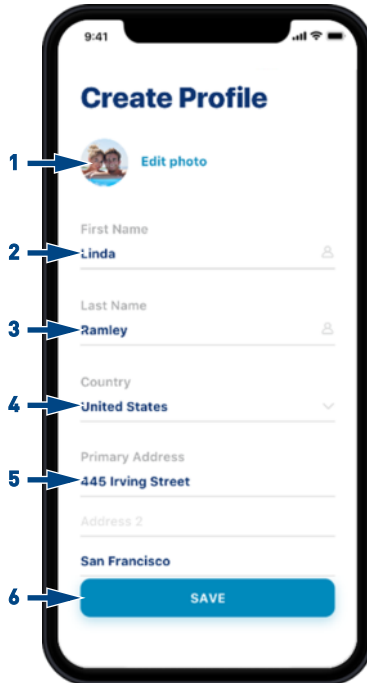



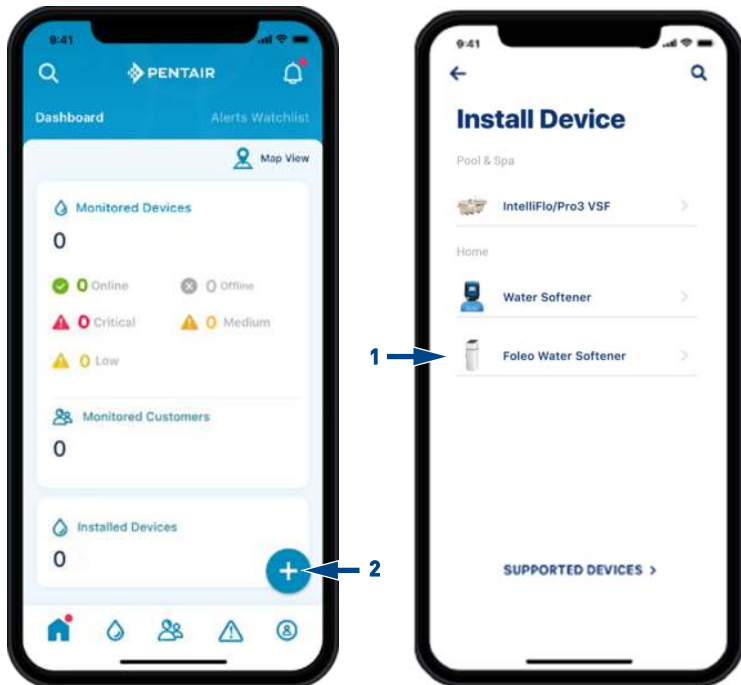

1. Press on Edit photo (1) to select a profile picture.
2. Enter the first name (2) and the name (3) of the device owner.
3. Enter the country (4) and the address (5) where the device is installed.
4. Press on **SAVE** (6) to register.
 - ⇒ The app goes to Dashboard to Add a device [→Page 67].

5.7.5 Add a device

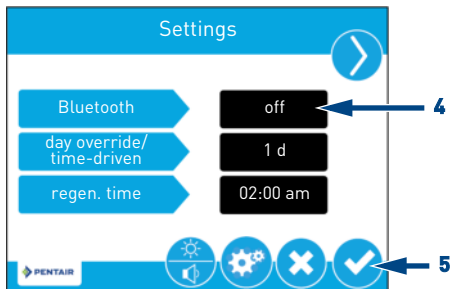
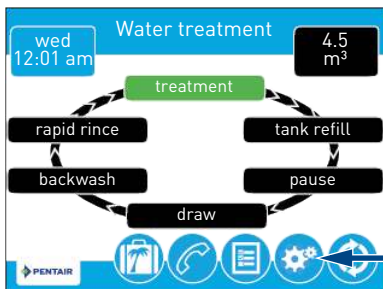

1. To add a device, click on the + [2].
2. Select Water Softener [1].



3. From the XTRi controller, press  [3] on the main screen to proceed the settings.
4. Turn the Bluetooth to **ON** [4] and then press  [5].
 - ⇒ A Bluetooth icon will appear in the upper right- hand corner of the main screen.
 - ⇒  : Bluetooth is open, but not connected.
 - ⇒  : Bluetooth signal is open and connected.

⇒  will show up on the screen until a WiFi connection has been established.

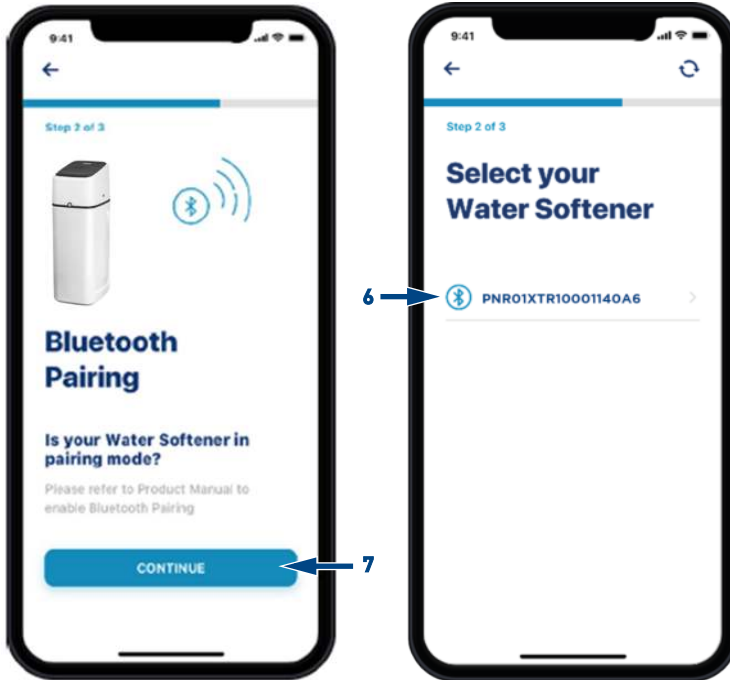

5. Once the Bluetooth signal is open on the screen, press on **CONTINUE** (7) to scan for the device.

⇒ Some available devices will appear.

6. Select the desired device (6).

⇒ You can see here your PNR Softener code.

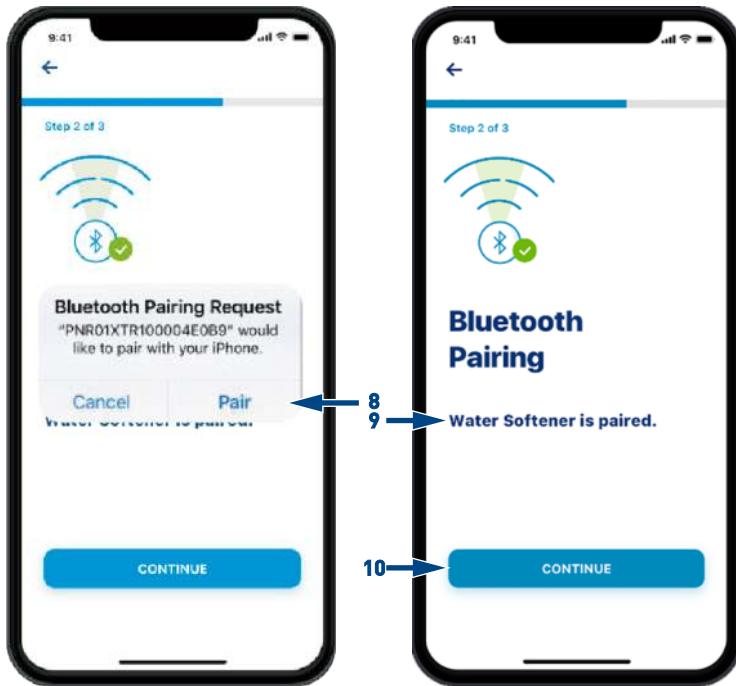

7. Press on **Pair** (8) to authorize the pairing of the device.
8. Wait that pairing is complete (9).
 - ⇒ For Pentair Pro App, set up is complete.
 - ⇒ For Pentair Pool app, please proceed to the screens to set up the WiFi connections as referenced in the Pentair Home Homeowner Guide.
9. Press on **CONTINUE** (10).



⇒ In the Pentair Pro app, the device **(11)** will now show up in the installed devices with their PNR numbers.

6 Commissioning

Info



This chapter is given for variable refill/brining regeneration types only.

Contact your supplier if you need assistance.

6.1 Softener commissioning

6.1.1 Water filling, draining and waterproofness inspection

Once the previous initial programming steps are performed, that the softener is in place and hydraulically connected to the main water line (see Softener installation [→Page 30]), the unit can be started up.

Follow these steps carefully:

1. With the bypass still in bypass position (inlet and outlet of the valve closed), plug in the XTRI controller to the power source.
2. Proceed to programming according to your system specification if not done yet.
3. Start a manual regeneration by pressing the regen button and select **Regen now**. Advance to backwash cycle by pressing . The piston will move into backwash position. Once in this position, unplug the XTRI controller from the power source.
4. Open the nearest faucet close to the system.
5. With the bypass still in bypass position, put the bypass slowly in service position. The valve and tank will slowly get filled with raw water, allowing air to be purged by the drain and/or by the open faucet next to the system. Open the inlet progressively until fully open position.
6. Once the drain runs clear and the bypass valve is fully in service position, plug in again the XTRI controller to the power source.

6.1.2 Quick cycling

1. Push on the regen button once to move the piston to rapid rinse cycle position. Leave the valve 1 minute in this position and advance to service. Start again a manual regeneration, see Manual regeneration [→Page 75]. When refill cycle is displayed, let the valve run the entire cycle and check the level of water in the brine tank or cabinet.

Info



Even variable refill/brining is set on, since it has been no water consumption, but a manual regeneration is started, a 100 % regeneration, regardless from consumption, is started.

2. When refill cycle is finished, the piston moves to brine draw position. Check to see in the brine tank if the water level decrease.
3. Once the draw function is observed and confirmed (level of water in the brine tank or cabinet has decreased), you may go through each remaining cycles pushing on the regen button until rapid rinse. Leave the complete cycle run to be sure that the brine draw in the system during draw test is rinsed out.

6.1.3 Startup

1. Fill the brine tank in the cabinet with salt.
2. Adjust the safety brine valve in the brine well to make sure the overflow elbow is installed above the float level.
3. After the softener has been running a few minutes in service, proceed to hardness test on outlet water to make sure the water is treated as per requirements, and eventually adjust the mixing device accordingly.

Info



Pentair advise to set a residual hardness between 50 and 100 mg/L of CaCO₃.

6.2 Cleaning, disinfection and sanitization

The construction materials of the modern water softener will not support bacterial growth, nor will these materials contaminate a water supply. During normal use, a softener may become fouled with organic matter, or in some cases with bacteria from the water supply. This may result in an off-taste or odour in the water. In this case, the tank of the softener must be cleaned and disinfected.

Some softeners may need to be disinfected after installation and some softeners will require periodic disinfection during their normal lifetime.

Depending on the conditions of use, the softener type, the type of ion exchanger, and the disinfectant available, a choice can be made among the following methods.

6.2.1 Cleaning of softeners

Make sure the brine tanks remains free from debris, waste, scraps that could be drown in the valve during brine draw cycles of regenerations. Make sure the softener and its parts remains clean to ensure proper function. Note that camshaft positioning is made by a optical sensor. Should this optical sensor be obstructed, malfunctions may happen.

6.2.2 Disinfection with sodium or calcium hypochlorite

These materials are satisfactory for use with polystyrene resins, synthetic gel zeolite, greensand and bentonites.

6.2.2.1 5.25 % Sodium hypochlorite

If stronger solutions are used, such as those sold for commercial laundries, adjust the dosage accordingly.

Dosage

Polystyrene resin: set 1.25 ml per liter of resin.

Brine tank softeners

Backwash the softener and add the required amount of hypochlorite solution to the well of the brine tank. The brine tank should have water in it to permit the solution to be carried into the softener.

Proceed with the normal regeneration.

6.2.2.2 Calcium hypochlorite

Calcium hypochlorite, 70 % available chlorine, is available in several forms including tablets and granules. These solid materials may be used directly without dissolving before use.

Dosage

Measure 0.11 ml per liter of resin.

Brine tank softeners

Backwash the softener and add the required amount of hypochlorite to the well of the brine tank. The brine tank should have water in it to allow the chlorine solution from being carried into the softener.

Proceed with the normal regeneration.

7 Operation

7.1 Display during operation

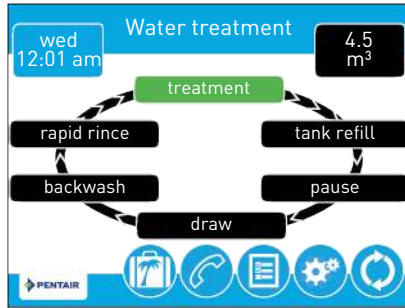

7.2 Display during regeneration

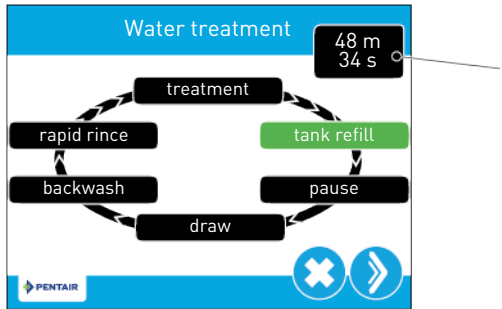

During regeneration, the regeneration cycle wheel shows the regeneration step the valve is advancing to, or has reached (green), and the time remaining in that step **(1)**. Once all regeneration steps are complete the valve returns to treatment position and resumes normal operation. The time remaining in regeneration will be displayed on the home screen in hours and minutes.

Pressing the button during a regeneration cycle immediately advances the valve to the next cycle step position and resumes normal step timing. The button is only shown when the valve is in position and the motor has stopped.

7.3 Controller operation during programming



The controller can only be programmed with the valve in treatment. While being programmed the controller continues to operate normally, monitoring water usage and keeping all displays up to date. Controller programming is stored in memory permanently until reset.

7.4 Manual regeneration

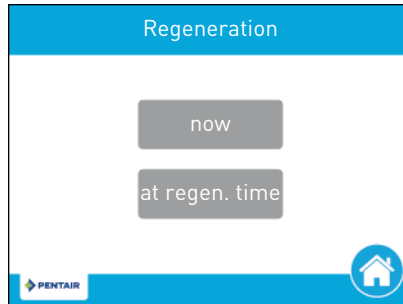
From the home screen, press the regeneration button  to access the regeneration screen.



Press **now** to begin a regeneration immediately, or press **at regen. time** to queue the regeneration for the programmed regeneration time (2:00 AM default for softeners, 12:00 AM default for filters). Pressing **at regen. time** again will cancel the manual regeneration.

1. During regeneration, press the button  to immediately advance to the next cycle step. Once in regeneration, the volume or time will be displayed below the button .

Info



When a manual regeneration is launched, 100 % of the resin bead is regenerated.

7.5 Operation during a power failure

The XTRi controller includes internal power backup. In the event of power failure, the controller shifts into a power-saving mode. The controller stops monitoring water usage. The display and motor shut down, but it continues to keep track of the time and day for a minimum of eight hours.

The system configuration settings are stored in a non-volatile memory and are stored indefinitely with or without power. After a long power outage, the time of day button may flash indicating it needs to be reset. Press the button to stop the time of day from flashing and reset time if needed.

If power fails while the unit is in regeneration, the controller will save the current valve position before it shuts down. When power is restored, the controller will resume the regeneration cycle from the point where power failed. If power remains off for more than eight hours, upon power restoration the regeneration is cancelled and the piston returns to service.

Caution - material



If power fails during a regeneration cycle, the valve will remain in its current position until power is restored.

The valve system should include all required safety components to prevent overflows resulting from a power failure during regeneration.

Caution - material**Risk of damage due to power failure!**

Without power, the valve stays in its current position until power is restored.

The system should include all required safety components to prevent overflows resulting from a power failure during regeneration.

The controller will not start a new regeneration cycle without power. If the valve misses a scheduled regeneration due to a power failure, it will queue a regeneration. Once power is restored, the controller will initiate a regeneration cycle the next time that the time of day equals the programmed regeneration time. Typically, this means that the valve will regenerate one day after it was originally scheduled. If the treated water output is important and power interruptions are expected, the system should be set up with a sufficient reserve capacity to compensate for regeneration delays.

7.6 Remote lockout

If a remote lockout is installed, the controller will not allow the system to go into regeneration until the regeneration lockout input signal to the controller is cleared. This requires opening the contact closure to clear the lockout condition. See Electrical connection [→Page 36].

7.7 Sleep mode

The controller will go into sleep mode if no button is pressed after five minutes. All other controller functions will continue to operate. The display will wake from sleep mode when any part of the display is touched.

8 Maintenance

Mandatory



Cleaning and maintenance shall take place at regular intervals in order to guarantee the proper functioning of the complete system, and be documented in the Maintenance chapter in the User Guide document.

Mandatory



The maintenance and service operation must be done by qualified personnel only.

Failure in respecting this may void the warranty.

8.1 General system inspection

Tip



Has to be done once a year at minimum!

Disinfect and clean the system at least once a year or if the treated water has an off-taste or an unusual odour.

8.1.1 Water quality

1. Raw water total hardness.
2. Treated water hardness.

8.1.2 Mechanical checks

1. Inspect general condition of valve and associated ancillaries and check for any leaks, ensure valve connection to piping is made with adequate flexibility as per manufacturer instruction.
2. Inspection of electrical connections, verify wiring connections and search for evidence of overloading.
3. Verify settings of electronic or electromechanical timer, verify regeneration frequency, make sure the valve configuration corresponds to the settings.
4. Check water meter, if present, report water meter settings, compare with previous inspection.
5. Verify total water consumption compared to previous visit.
6. If pressure gauges are installed before and after softening system, verify and record static and dynamic pressure, reporting pressure drop. Verify that inlet pressure respects valve and softening system limits.
7. If pressure gauges are not present, but suitable points exist, install temporary pressure gauge(s) to perform precedent point.

8.1.3 Regeneration test

1. Check condition of brine tank and any associated equipment.
2. Check salt level in brine tank.
3. Initiate regeneration test.
 - ⇒ Check brine draw during brine draw stage.
 - ⇒ Check brine tank refill.
 - ⇒ Check operation of safety brine valve, where fitted.
 - ⇒ Check for brine draw off levels.
 - ⇒ Check for resin loss at the drain during regeneration.
 - ⇒ Where fitted, check for satisfactory operation of solenoid, i.e. outlet shut off during regeneration and/or brine line shut off valve(s).
4. Test and record Total Hardness of outlet water from softener vessel(s).

8.2 Recommended maintenance plan

Items	1 year	2 year	3 year	4 year	5 year
Injector & filter	Clean	Clean	Clean	Clean	Clean/replace if necessary
BLFC***	Clean	Clean	Clean	Clean	Clean/replace if necessary
DLFC***	Clean	Clean	Clean	Clean	Clean/replace if necessary
Bypass (contains Orings***)	Clean	Clean	Clean	Clean	Clean/replace if necessary
Piston*	****	Replace	****	Replace	****
Seals & spacers*	****	Replace	****	Replace	****
Brine valve	Check/clean/replace if necessary	Check/clean/replace if necessary	Check/clean/replace if necessary	Check/clean/replace if necessary	Check/clean/replace if necessary
O-rings***	Check for watertightness /clean or replace in case of leakage	Check for watertightness /clean or replace in case of leakage	Check for watertightness /clean or replace in case of leakage	Check for watertightness /clean or replace in case of leakage	Check for watertightness /clean or replace in case of leakage
Motor	Check	Check	Check	Check	Replace
Optical sensor	Check	Check	Check	Check	Replace
Gearing	Check	Check	Check	Check	Check/replace if necessary
Encoding wheel	Clean	Clean	Clean	Clean	Clean

Items	1 year	2 year	3 year	4 year	5 year
Inlet hardness	Check	Check	Check	Check	Check
Residual hardness	Check/adapt mixing screw if necessary	Check/adapt mixing screw if necessary	Check/adapt mixing screw if necessary	Check/adapt mixing screw if necessary	Check/adapt mixing screw if necessary
Electronic/settings**	Check	Check	Check	Check	Check/replace if necessary
Transformer**	Check	Check	Check	Check	Check/replace if necessary
Meter*	Check and Clean	Check and Clean	Check and Clean	Check and Clean	Replace
Meter cable	Check	Check	Check	Check	Replace
Valve watertightness	Check	Check	Check	Check	Check
Valve to piping watertightness	Check	Check	Check	Check	Check
Brine tank & brine well	Clean	Clean	Clean	Clean	Clean
Safety brine valve	Check and clean	Check and clean	Check and clean	Check and clean	Check/clean/replace if necessary
Air check	Check and clean	Check and clean	Check and clean	Check and clean	Check/clean/replace if necessary
Brine tube	Clean	Clean	Clean	Clean	Check/clean/replace if necessary
Brine line	Clean	Clean	Clean	Clean	Check/clean/replace if necessary
Cabinet body and cover (external)	Clean	Clean	Clean	Clean	Clean

* Wear parts - durability strongly affected by raw water quality and regeneration frequency.

** Electronic parts - durability strongly affected by power source quality and stability.

*** Elastomer durability is strongly affected by raw water concentration in chlorine and its derivative.

**** Seals & Spacer cartridge is equipped with O-rings that ensure watertightness by compression, therefore by unmounting/remounting the same cartridge may cause it not to be watertight anymore, each time the seals & and spacer cartridge is extracted from the valve body it must be pre-placed by a new one. Note that extraction the piston may also extract the Seals and spacer cartridge at the same time for this reason it not advised to unmount the piston, clean and lubricate it with silicon grease as with former residential fleck valves for the regular maintenance, but only to replace it at least every 3 years.

8.2.1 Maintenance instructions

- Disinfect and clean the system at least once a year or if the treated water has an off-taste or an unusual odour.

8.3 Adding salt

Tip



Do not fill the brine tank with too much salt if you are approaching to brine tank cleaning date.

1. Open the salt lid (1) pressing at point (2).
2. Make sure the brine well (4) is closed by its cap.
3. Dump salt in the funnel (3) leaving the brine well (4) uncovered for a minimum of 2 cm.
4. Close the salt lid (1).

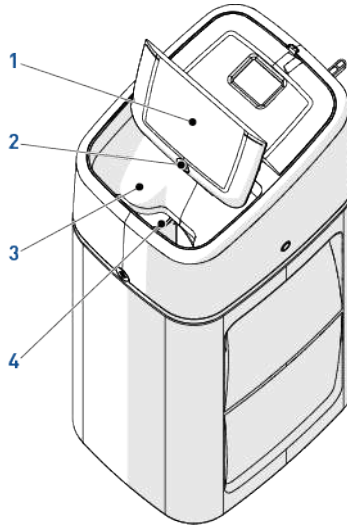

8.4 Recommendations

8.4.1 Use original spare parts

Caution - material



Risk of damage due to use of non-genuine spare parts

To ensure correct operation and safety of the device, only use original spare parts and accessories recommended by the manufacturer.

Usage of non-genuine spare parts voids all warranties.

Parts to keep in stock for potential replacements are the pistons, S&S kit, injectors, optical sensor and motors, controllers and power adapter BLFC and DLFC.

Refer to maintenance sheet.

8.4.2 Use original approved lubricants

- P-80[®] Emulsion lubricant (water base lubricant).

8.5 Cleaning and maintenance

8.5.1 First steps

Before any cleaning or maintenance procedure, complete the following steps:

Mandatory



These operations must be performed before any cleaning or maintenance procedure!

1. Unplug the wall-mounted transformer.
2. Shut off water supply or put bypass valve(s) into bypass position.
3. Relieve system pressure before performing any operations.

8.5.2 Softener cover removal

CAUTION

 **Do not pull on the cables. Release the connectors from components by pressing on their locking clips.**

1. Unclip (3) and open the controller cover (2).
2. Unlock the cover (1) from the slide clips (4) (one on each side of the cover).
3. Remove the cover (1).
4. Reverse above procedure steps to rebuild.

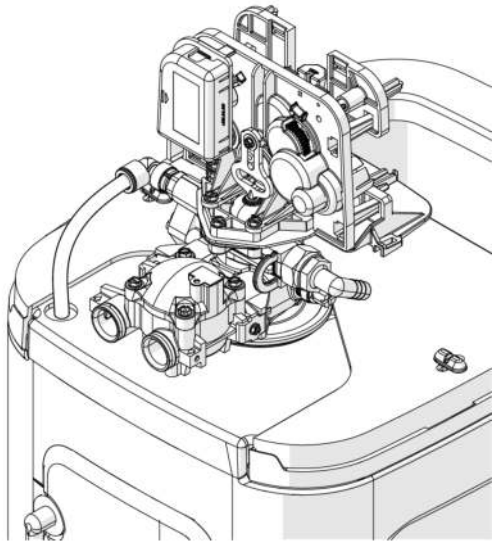
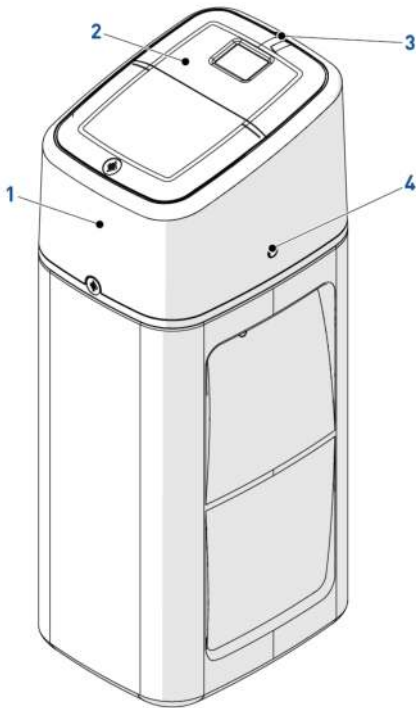

8.5.3 Brine tank, brine well, safety brine valve and air check cleaning

1. Remove the softener cover (2), see First steps [→Page 81] and Softener cover removal [→Page 82].
2. Turn the clips (11) 90 degrees, remove the cabinet plate (10) and the brine well cover (9).
3. Remove the safety brine valve clip (6).
4. Unscrew the nut and pulled the brine valve tube (4) out of the safety brine valve body (5).
5. Remove the brine tank (12) and brine well (7) from cabinet (3).
6. Transfer the remaining salt from brine tank (12) to a basket.

 CAUTION

Do not lay down or flip over the softener to empty the brine tank.

7. Remove the brine valve body (5) and the air check (13) from the brine well (7).
8. Clean the brine tank (12), the brine well (7), the brine valve (4), the brine valve body (5) the air check (13) and the salt funnel (1) with water and sponges.
9. Reverse above procedure steps to rebuild.
10. Fill the brine tank (12) with salt, see Adding salt [→Page 80].

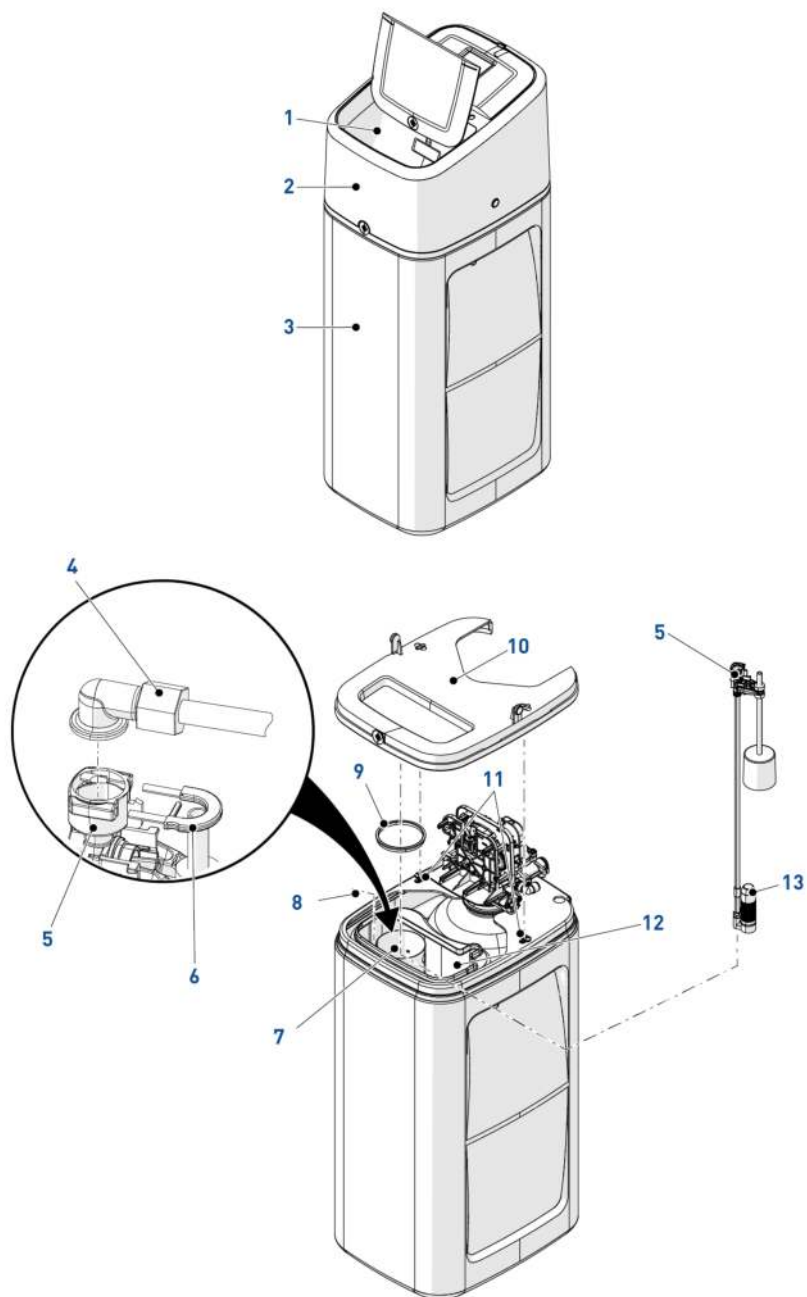

8.5.4 Injector and injector screen cleaning

1. Remove the softener cover, see First steps [→Page 81] and Softener cover removal [→Page 82].
2. Remove the injector cap screws (3).
3. Remove the injector cap (2).
4. Remove the seal (4) taking note of its position.

Caution - material



Depending of configuration, the position of the seal can be different as shown. The mid part of the seal should be aligned with the position of the injector.

5. Using a flat screw driver remove the injector (5).

Caution - material



To avoid any damage on the injector, use only the dedicated puller to remove it.

6. Remove the screen (6).
7. Clean or change the injector (5), the screen (6) and the seal (4).
8. Lubricate all seals with approved lubricant only.

Caution - material



Using another type of lubricant, such as petroleum-based lubricants (Vaseline, oils, or hydrocarbon-based lubricants) or silicone grease, may damage the valve.

9. Reverse above procedure steps to rebuild.

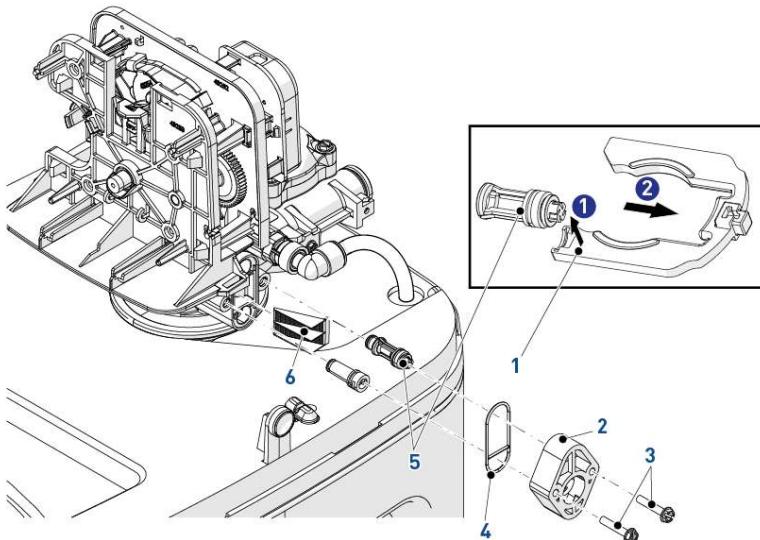

8.5.5 Controller replacement

Caution - material



Do not pull on the cables. Release the connectors from components by pressing on their locking clips.

1. Unclip (2) and remove the controller cover (1).
2. Put the controller cover (1) in a vertical position on the Bypass.
3. Unscrew (6) and remove the cover box (5).
4. Unclip (3) and remove the controller (4) from the cover box (5).
5. Disconnect the controller cables (not shown).
6. Change the controller (4).
7. Reverse above procedure steps to rebuild, see XTRi controller connection [→Page 36].

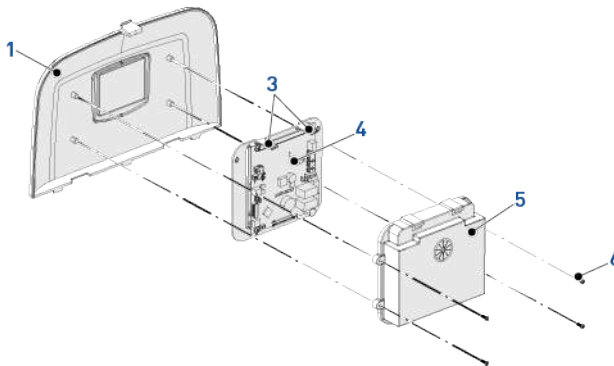
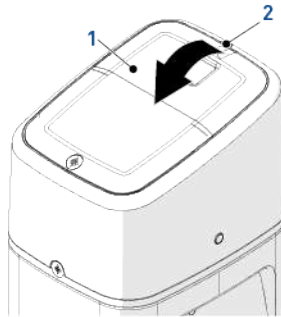

8.5.6 IoT board replacement

1. Remove the softener cover, see First steps [→Page 81] and Softener cover removal [→Page 82].
2. Press on the clip (5) and remove the board cover (4).
3. Disconnect the IoT board (3).
4. Free the board clips (2) and release the IoT board (3) from support (1).
5. Clip the new IoT board (3) on the support (1).
6. Connect the new IoT board (3), see XTRi controller connection [→Page 36].
7. Fit in place the board cover (4).
8. Fit in place the softener cover, see Softener cover removal [→Page 82].

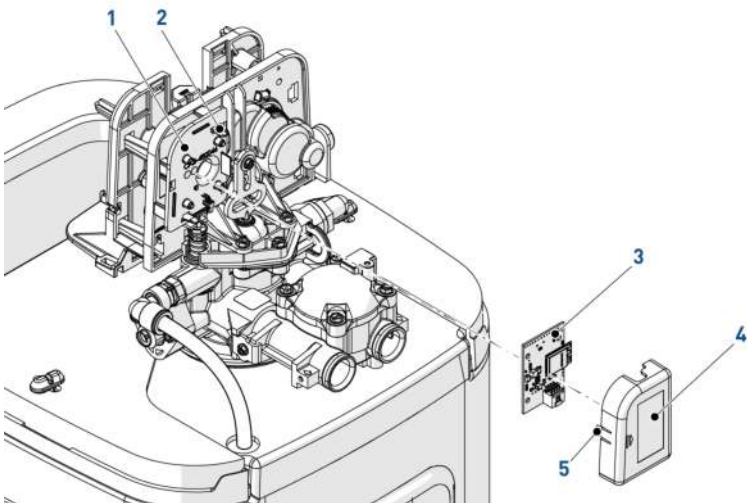

8.5.7 Brine valve and/or piston and seals & spacers replacement

1. Remove the gearing system, see Power head disassembly/replacement [→Page 93].
2. Remove the screws (1).
3. Remove the piston (3) and the top plate (2) by pulling the top plate (2) on the points indicated by arrows.
4. Remove the brine valve (7).
5. Change the piston (3) and the seals & spacers cartridge (5).

Mandatory



Pentair recommends always to change piston and seals & spacers simultaneously!

Info



The larger spacer (6) is the lower part of the seals & spacers cartridge.

6. Change or clean the brine valve (7).
7. Lubricate all seals (4 + 5 + 7) and with approved P-80® Emulsion lubricant only.

Caution - material



Risk of damage due to wrong lubricant use

Do not use petroleum-based lubricants such as Vaseline, oils, or hydrocarbon-based lubricants.

Do not use silicon grease.

Use only P-80® Emulsion lubricant (water-based lubricant)!

8. Reverse above procedure steps to rebuild.

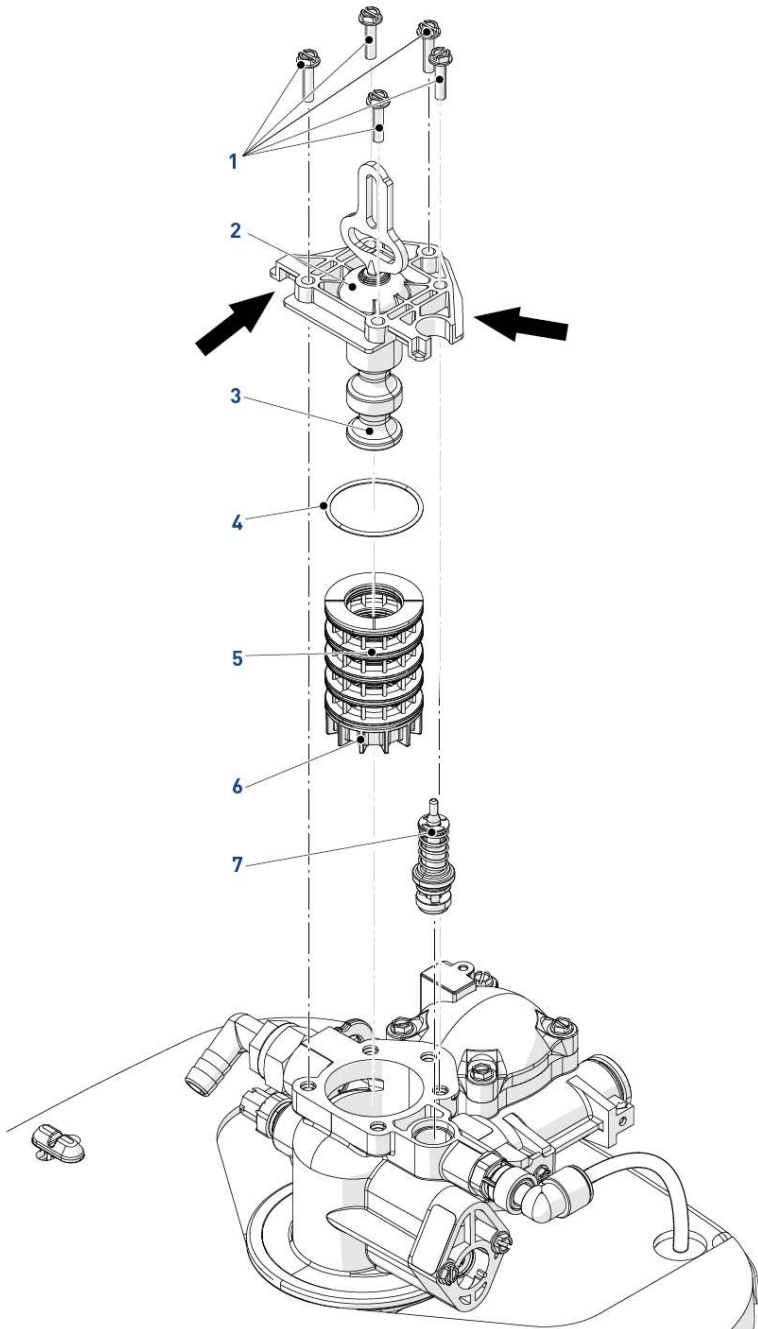

8.5.8 Other wear and tear parts

8.5.8.1 DLFC cleaning

1. Remove the softener cover, see First steps [→Page 81] and Softener cover removal [→Page 82].
2. Remove the DLFC locking clip (1) and the DLFC housing (4).
3. Insert one of the pin of the DLFC locking clip (1) in the DLFC washer (2) and extract it from the DLFC housing (4).
4. Clean DLFC (2) using a soft brush or compressed air.
5. Lubricate the seal (3) with approved P-80® Emulsion lubricant only.

Caution - material



Using another type of lubricant, such as petroleum-based lubricants (Vaseline, oils, or hydro-carbon-based lubricants) or silicone grease, may damage the valve.

6. Reverse above procedure steps to rebuild.

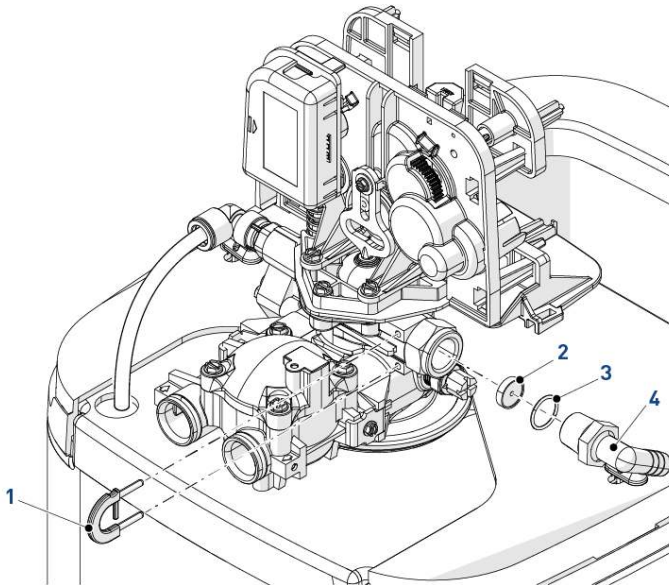

8.5.8.2 Motor replacement

1. Remove the softener cover, see First steps [→Page 81] and Softener cover removal [→Page 82].
2. Disconnect the optical sensor (3).
3. Open the motor clips (1) and pull out the old motor (2).

Caution - material



Do not pull on motor cables to extract the motor from its location.

4. Change the motor (2).
5. Reverse above procedure steps to rebuild.

Tip



When re-inserting the motor, it may be required to manually turn the gear (4) of the gearbox to align the motor and the gearbox making the motor inserting easier.

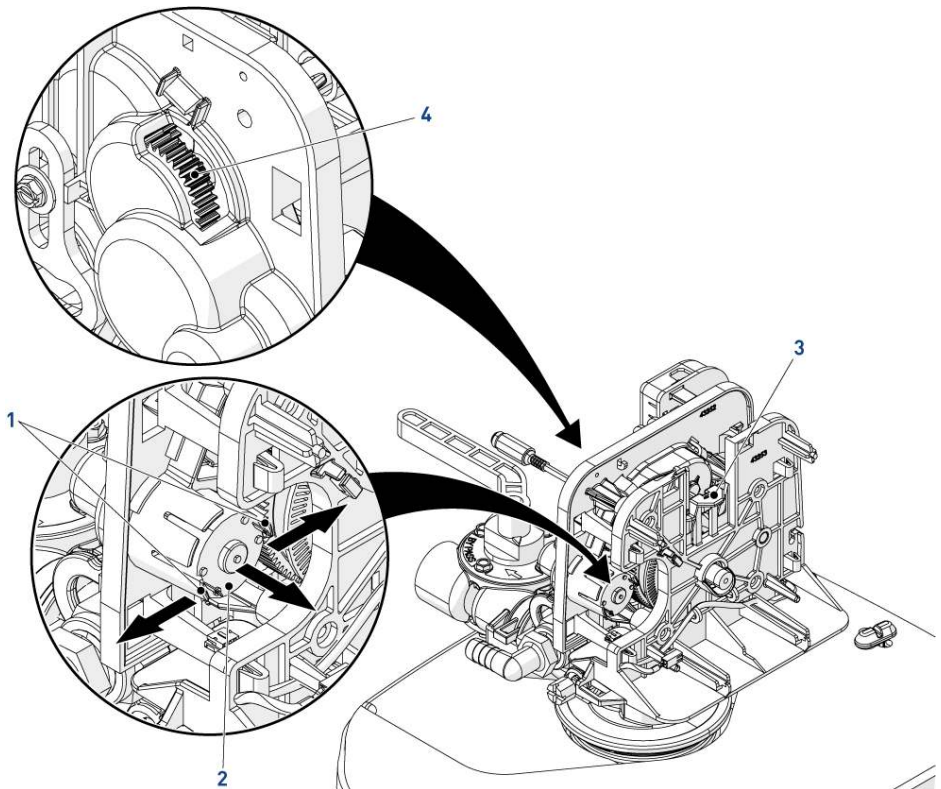

8.5.8.3 BLFC cleaning

1. Remove the softener cover, see First steps [→Page 81] and Softener cover removal [→Page 82].
2. Disconnect the tube (7) (push fit system (6)).
3. Using a wrench, unscrew the BLFC holder (5) from valve (1).
4. Using pliers, remove the grid (2) from BLFC holder (5).
5. Remove the BLFC (3) from the grid (2).
6. Clean or change the BLFC (3).
7. Lubricate the seal (4) with approved P-80® Emulsion lubricant only.

Caution - material



Using another type of lubricant, such as petroleum-based lubricants (Vaseline, oils, or hydro-carbon-based lubricants) or silicone grease, may damage the valve.

8. Reverse above procedure steps to rebuild.

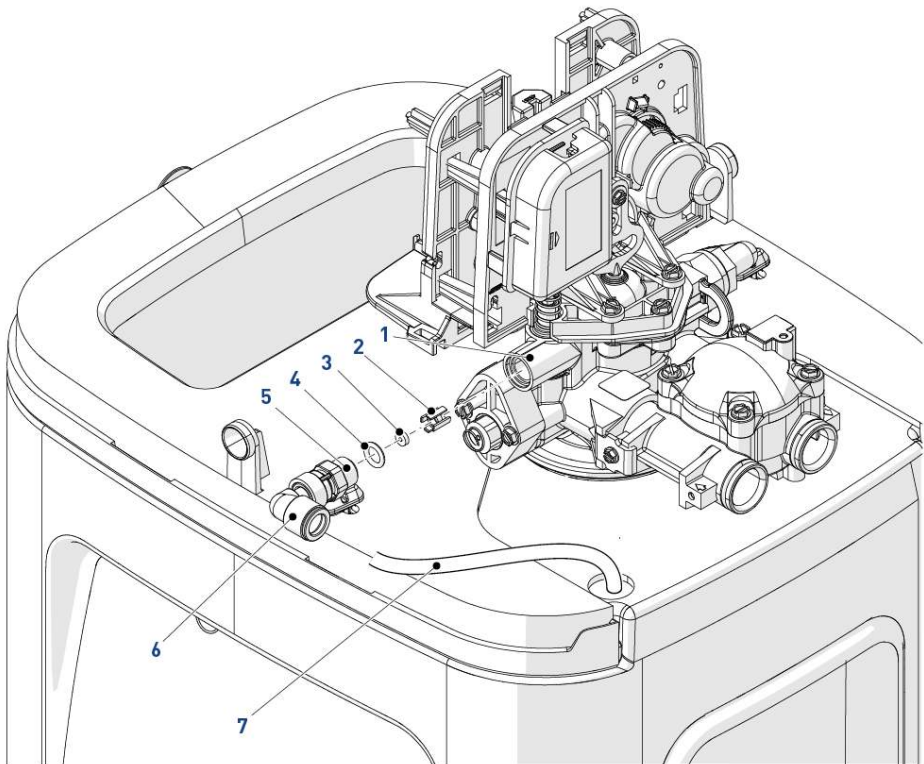

8.5.8.4 Power head disassembly/replacement

1. Remove softener cover, see First steps [→Page 81] and Softener cover removal [→Page 82].
2. Using a 6 mm wrench or flat screwdriver, unscrew (2).
3. Using a 8 mm wrench or flat screwdriver, unscrew (1).
4. Separate the power head (3) from the valve body (4).
5. Change the power head (3).
6. Reverse above procedure steps to rebuild.

Caution - material

- ! When assembling the gearing system (3) on the valve body (4), make sure to put the brighter part of the piston axe (5) on the left when looking at the valve from behind as shown.

Tip



These operations need to be performed before any cleaning or maintenance procedure.

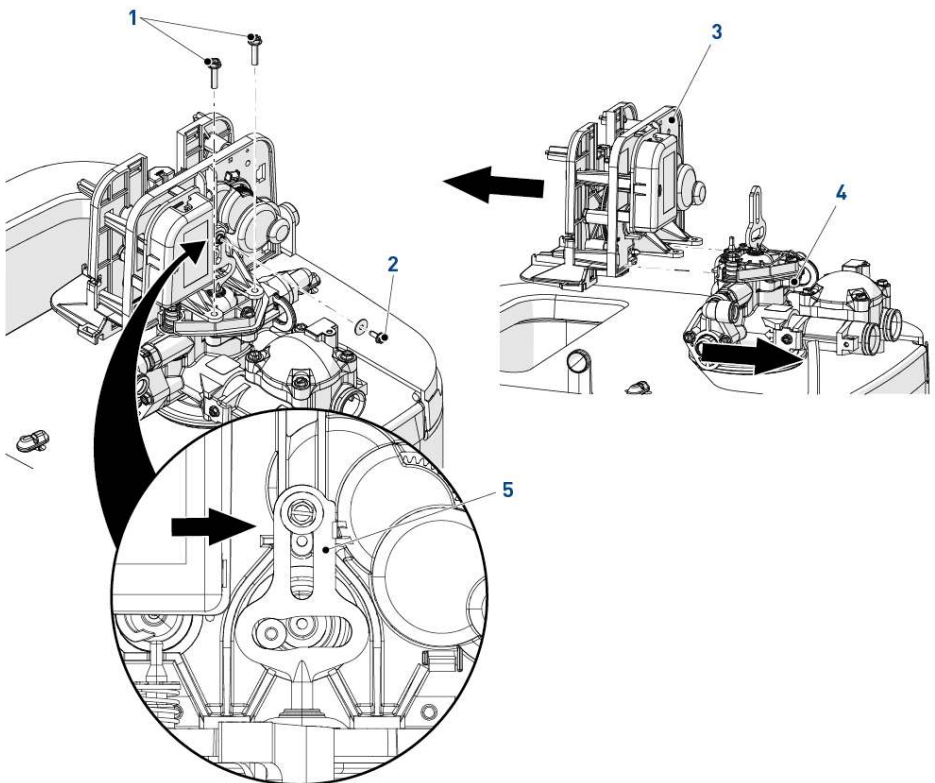

8.5.8.5 Optical sensor replacement

1. Remove the softener cover, see First steps [→Page 81] and Softener cover removal [→Page 82].
2. Disconnect the wire from the motor to the optical sensor (4).
3. Release the optical sensor support (1) by pushing it back and up as shown.
4. Release the optical sensor (3) from its support (1) by pressing the clips (2).
5. Change the optical sensor (3).
6. Reverse above procedure steps to rebuild.

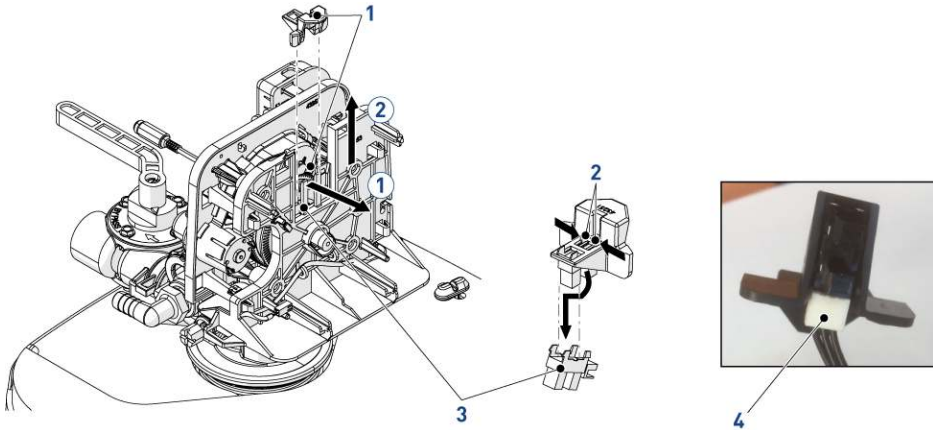

8.5.8.6 Encoding wheel cleaning

1. Remove the optical sensor, see Optical sensor replacement [→Page 94].
1. Remove the softener cover, see First steps [→Page 81] and Softener cover removal [→Page 82].
2. Remove the plate (7) by pushing the 4 clips (1).
3. Remove and clean the encoding wheel (6).
4. Eventually, removing the encoding wheel will cause the brine cam (3) and the gearbox output wheel (5) to fall. Remount starting with the brine cam (3), aligning the positioning holes (4) with the backplate hole (2).
5. Reverse above procedure steps to rebuild.

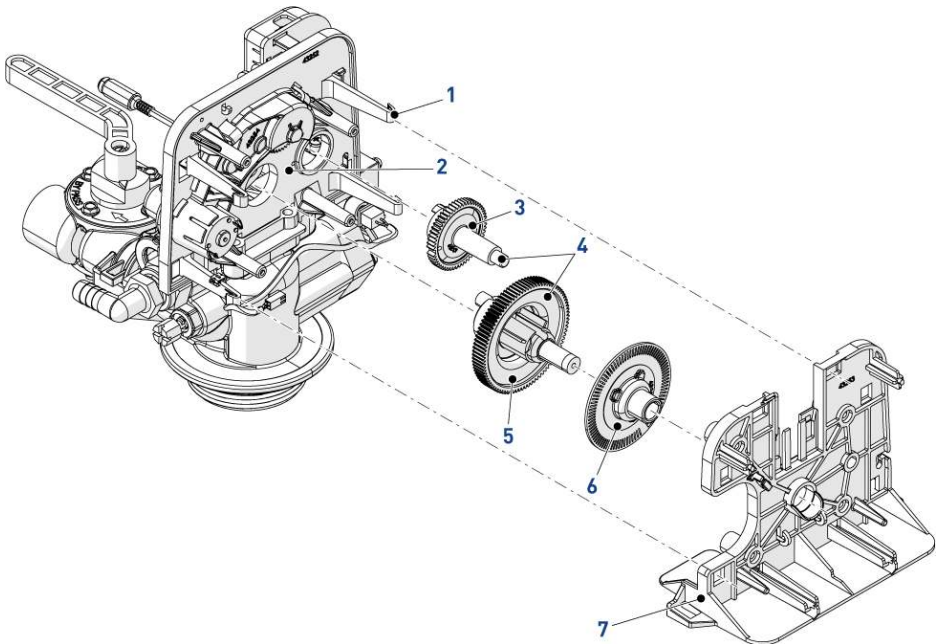

8.5.8.7 Disassembling/assembling valve from/on tank

1. Remove the softener cover, see First steps [→Page 81] and Softener cover removal [→Page 82].
2. Disconnect the wires from the IoT board, see Electrical connection [→Page 36].
3. Release the tube **(6)** from push-fit fitting **(1)**.
4. Remove the DLFC clip **(3)** and extract the DLFC assembly and elbow **(2)**.
5. Unscrew **(5)** and remove the meter **(4)**.
6. Unscrew, counter-clockwise, the valve **(8)** from tank **(7)**.
7. Perform maintenance or change the valve **(8)**.
8. Lubricate the valve tank adapter and riser tube O-rings with approved P-80[®] Emulsion lubricant only.

CAUTION



Using another type of lubricant, such as petroleum-based lubricants (Vaseline, oils, or hydro-carbon-based lubricants) or silicone grease, may damage the valve.

9. Spin the valve **(8)** onto the tank **(7)**, ensuring the threads are not cross-threaded.
10. Rotate the valve **(8)** clockwise and freely, without using force until it comes to a stop.

Info



This stop position is considered point zero.

11. Rotate the valve **(8)** clockwise from point zero to between ¼ turn and ½ turn.

CAUTION



Do NOT exceed 27 Nm of torque when installing the valve.

Exceeding this limit may damage the threads and cause failure.

12. Reverse steps **1.** to **4.** to rebuild.

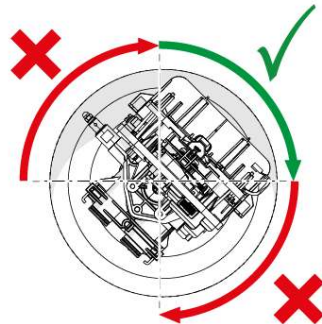
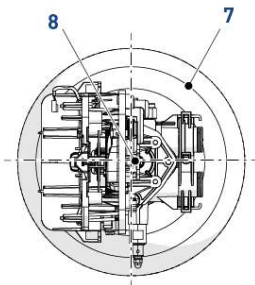
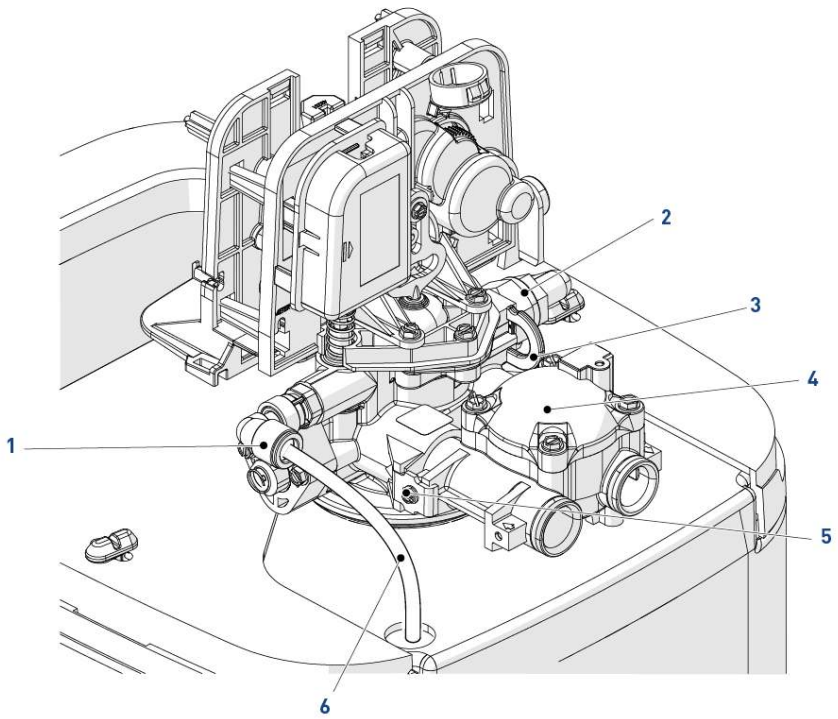

9 Troubleshooting

9.1 Controller

9.1.1 Error detection

If an error in valve or controller function occurs, an alarm will sound and the home screen will display the error alert button and the alarm button .

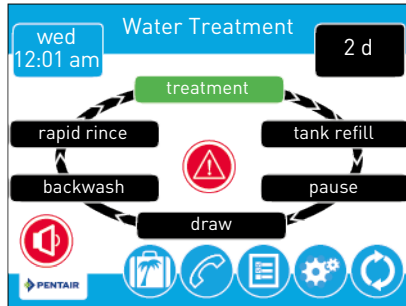

Press the alarm button to mute the alarm.

Press the error alert button to view information about the error.

If the display is in sleep mode when an error occurs, the screen will turn on for five minutes. The controller will beep once every 10 seconds until the error is cleared. If the error is not cleared after five minutes, the screen will switch to power saving mode and display the error alert button as a screen saver.

9.1.2 Error alerts

Info



An error alert appears on the home screen if an error condition is detected. Press the error alert button to view the error message.

Most error alerts are cleared at regeneration. If the error persists following a regeneration attempt the appropriate reset and recovery procedure below or contact technical support.

Error screen display	App Display	Cause	Reset and recovery
Optical Sensor Undesired change detected in the optical sensor	Optical sensor	An undesired optical sensor state change occurred.	Non-critical error. Extra optical sensor pulse detected. Press the Regeneration button to advance motor to clear error.

Error screen display	App Display	Cause	Reset and recovery
Flow meter error Continuous Flow	Flow meter	The flow meter has reported continuous flow for more than 24 hours.	Error will clear when flow to meter drops below 0.5 gpm or 1 Lpm. If continuous flow is expected, turn plumbing leak detection off in Master Settings.
Over current Motor over current detected	Over current	Motor drew too much current.	Attempt to perform a manual regeneration. If error continues, call technical support.
Flow meter error No flow detected	Flow meter	No flow has been detected for 7 days.	Error will clear when a flow pulse is detected. Check to ensure meter cable is properly installed and meter spins freely. Clear meter of debris if necessary. If error continues, call technical support.
No regeneration for 100 days	No regen 100 days	The valve has not regenerated in more than 100 days.	Initiate a regeneration see Manual regeneration [→Page 75].
Service Interval	Service interval	Service Interval controller has expired.	From within Master Settings, navigate to the Assistance/Mainten. Interval screen and set a new Service Interval time.
Motor Stall Motor Run-On No changes detected in the optical sensor for 6 seconds	Motor stall	No state changes in the optical sensor are detected for six seconds.	<p>Unplug the unit and plug back in. Allow the control to attempt to find position again.</p> <p>Verify the optical sensor is in place with the wires connected to the circuit board. Verify the motor and drive train components are in good condition and assembled properly. Check the valve and verify that the piston travels freely. Replace/reassemble the various components as necessary.</p> <p>Plug the unit back in and observe its behaviour. If the error reoccurs, unplug the unit, put it into bypass and contact technical support.</p>
- NA -	IOT Conn Failure	XTRi & IoT Board Communication not working.	Remove data cable. Reset IoT Board by reset button on top, then plug data cable back in.

Error screen display	App Display	Cause	Reset and recovery
- NA -	Offline	WiFi Connection has been disrupted for more than 60 minutes.	Verify that WiFi is not experiencing any issues.
Memory Corruption Error		Internal memory inconsistent or corrupted.	<ol style="list-style-type: none"> 1. Cycle power to XTRi /XTRi controller. 2. Drain supercap and cycle power to XTRi/XTRi controller. 3. If error continues, call technical support.

9.2 Valve

Problem	Cause	Solution
Flowing or dripping water at drain or brine line after regeneration.	Foreign debris caught between piston and seals & spacers.	Replace piston and seals & spacers.
	Incorrect piston position.	Clean the encoding wheel, clean or replace the optical sensor, check motor and gearing and replace if necessary.
Loss of capacity/hardness leakage at end of cycle.	Seasonal raw water hardness increase.	Check programming and update inlet hardness.
	Brine concentration and/or quantity.	Keep brine tank full of salt at all times. Clean it yearly. Salt may be bridged. If using a salt grid plate ensure refill water is over it.
	Resin fouling.	Call your supplier, find out how to confirm it, clean the resin and prevent future fouling. Eventually installing a pre-filter must be done.
	Poor distribution, channelling (uneven bed surface).	Call your supplier. Check distributors and backwash flow rate.
	Internal valve leak.	Call your supplier. Replace spacers, seals and/or piston.
	Resin age.	Call your supplier.
Valve cycles continuously.	Faulty controller.	Replace controller.
	Wrong programming.	Check programming.

Problem	Cause	Solution
Continuous flow to drain.	Foreign material in control valve.	Call your supplier. Clean valve, rebuild unit.
	Internal control valve leakage.	
	Valve jammed in regeneration position.	
	Motor stopped or jammed during regeneration.	Replace motor.

9.3 System

Issue	Cause	Reset and recovery
Water softener fails to regenerate automatically.	Cord plugged into intermittent or switched off power source.	Connect to constant power source.
	Disconnected/faulty meter cable.	Reconnect/replace cable.
	Defective power cord.	Replace cord.
	Defective controller, meter or sensor.	Replace or repair.
	Bad programming.	Program correctly.
Regeneration at wrong time.	Controller improperly set, due to power failure.	Update time of day and day of week programming.
Hard water leakage after regeneration.	Improper regeneration.	Control brine dosage setting and repeat regeneration.
	External bypass valve leaking.	Repair/replace bypass.
	O-ring around riser pipe damaged.	Replace o-ring.
	Incorrect controller settings.	Check that controller setting match with your actual softener model.
System regenerate always with 100% salt setting (possible variable refill malfunction).	Meter blocked.	Clean or change meter.
	Meter cable defective.	Change meter cable.
	Incorrect controller settings.	Check that controller setting match with your actual softener model.
	Water consumption depleted unit capacity.	Reset and recovery. Check water consumption in diagnostic mode. If registered water consumption match with unit capacity, this is then a normal behaviour. If not, contact your supplier.
No conditioned water after regeneration.	No brine in brine tank.	Add brine to brine tank.
	Injector plugged.	Clean injector and screen.

Issue	Cause	Reset and recovery
No water flow display on controller while water is currently being used.	Bypass valve in bypass.	Shift bypass valve to non-bypass position.
	Meter probe disconnected or not fully connected to meter housing.	Fully insert probe into meter housing.
	Restricted paddle meter rotation due to foreign matter in meter.	Remove meter housing, free up paddle and flush with clean water. Paddle should spin freely. If not, replace meter.
Run out of conditioned water between regenerations.	Improper regeneration.	Control brine dosage set and repeat regeneration.
	Incorrect brine setting.	Set brine to proper level. See Valve screen [→Page 51].
	Incorrect hardness or capacity settings.	Set hardness and capacity settings Regeneration screen [→Page 53] and Format screen [→Page 43].
	Water hardness has increased.	Check hardness settings. See Regeneration screen [→Page 53].
	Restricted paddle meter rotation due to foreign matter in meter.	Remove meter housing, free up paddle and flush with clean water. Paddle should spin freely. If not, replace meter.
	Too much water used between the first cycle of regeneration and brine draw.	Set regeneration times at low or no water usage. See Regeneration screen [→Page 53]. Eventually installing the optional Pentair® fast brine valve will be necessary. Contact your supplier.

Issue	Cause	Reset and recovery
Brine tank overflow.	Air leak in brine line.	Check all connections in brine line for any leaks.
	Incorrect BLFC size with regards to injector size.	Use of too small BLFC with large injector will reduce draw rates.
	BLFC/DLFC causing inconsistent brine draw clogged with resin or other debris.	Clean BLFC & DLFC.
	Incorrect controller settings.	Check that controller setting match with your actual softener model and/or valve configuration.
	Injector plugged causing refill instead of drawing.	Clean injector. See Injector and injector screen cleaning [→Page 85].
	Valve fails to draw brine in brine draw cycle.	Check for seals & spacers integrity. Clean or replace if necessary.
		Check upper screen cleanliness. Clean or replace if necessary.
		Check inlet pressure. Make sure it is above 1.4 bar dynamic.
Check safety brine valve and air check. Clean, repair or change if necessary.		
Check for leak/air intake in brine line. Change if necessary.		
Check if brine line is not plugged or partially obstructed. Remove plug if necessary.		
Check if drain line is not plugged or partially obstructed. Remove plug if necessary.		

10 Spare parts

10.1 Softener

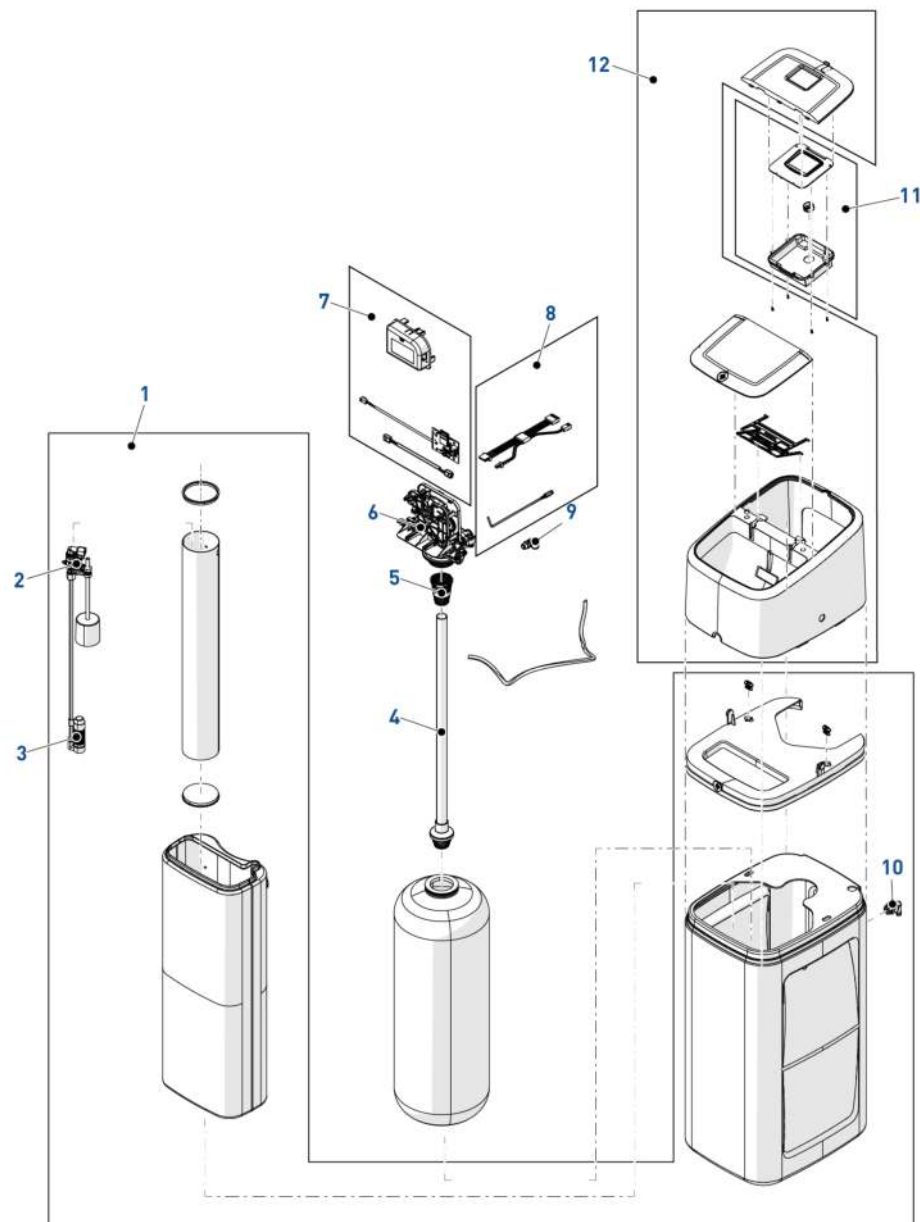

Item	Part number	Description	Package quantity
1	K-CAB-5000011	Foleo cabinet assy mini	1
-	K-CAB-5000012	Foleo cabinet assy maxi	1
2	60014SP	Safety brine valve	10
3	18168	Air Check 500 (0.915 m)	48
4	27827-DW	Riser tube	24
5	18280SP	Top distributor 1" grey	10
6	CAB-V580XRI-008	Complete valve Foleo 10	1
-	CAB-V580XRI-009	Complete valve Foleo 15	1
-	CAB-V580XRI-010	Complete valve Foleo 20	1
-	CAB-V580XRI-011	Complete valve Foleo 30	1
7	K-CAB-500011	Wifi upgrade kit	1
8	K-CAB-5000013	Foleo kit cables	10
9	27121SP	Quick Fit elbow 3/8"	10
10	E011180	Overflow elbow	50
11	K-CAB-5000014	Foleo PCB assy, programmed as 20 L	1
12	CAB-400040	Foleo cover assy	1

10.1.1 Safety brine valves 2310 parts list

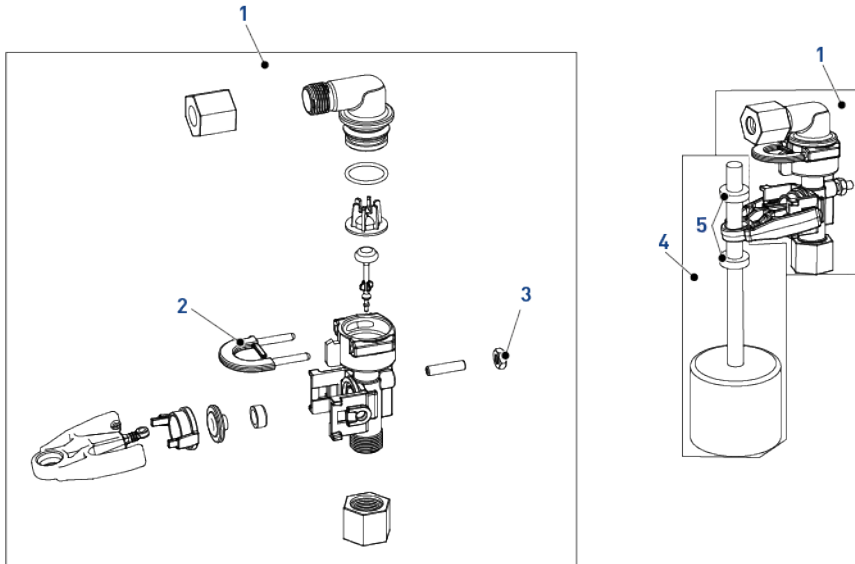

Item	Part number	Description	Packaging quantity
1	60014SP	Body assy SBV, 2310	10
2	18312SP	Retainer, Drain	10
3	19805SP	Nut SBV, 2310, Plastic	50
4	60068-30SP	New float assy, 2310	10
5	10150SP	Grommet pass rod, 2300/2310/2350	50

10.2 Valve

10.2.1 Valve body parts list

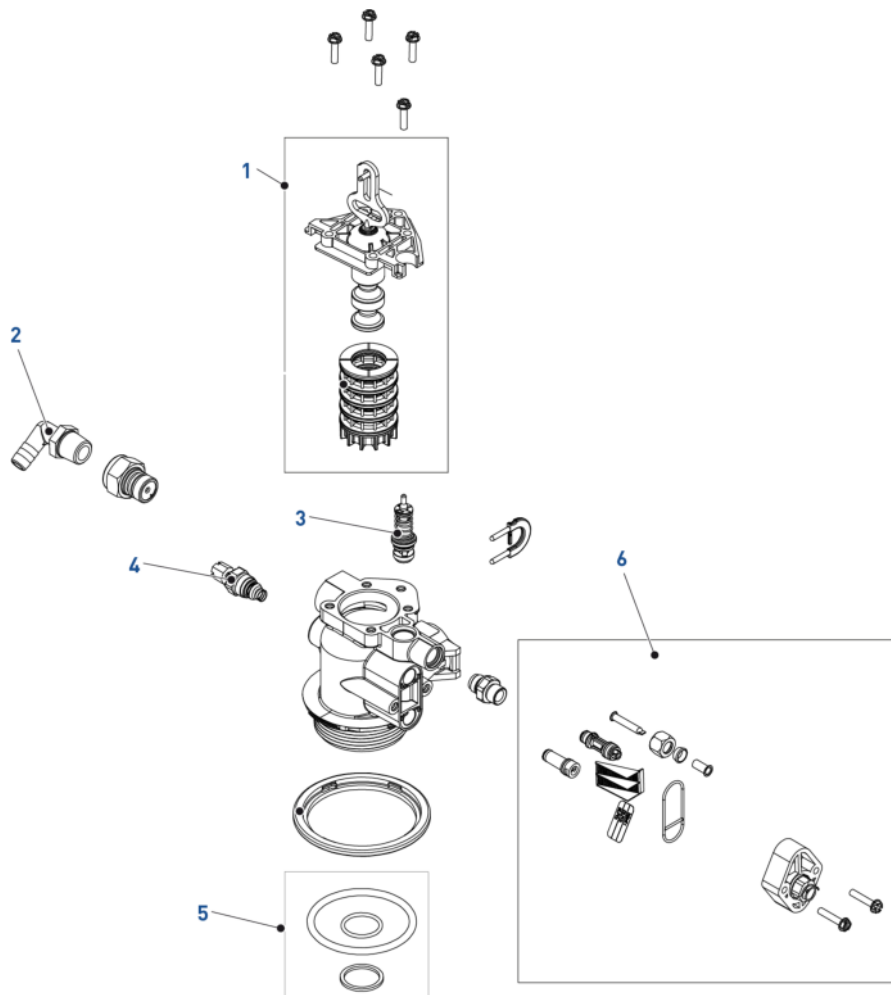

Item	Part number	Description	Packaging quantity
1	BR61838	Piston assy 5800 UF	1
2	21511SP	Hose Barb 90° ½" x ½", black grey	10
3	24114	BV assy 1600 Residential	1
4	24509-01	Mixing assy residential	1
5	29152	Kit O-rings tank adapter 5800/5000/9100/2510	10
6	29154	Injector kit 5800 UF #000 to 3	1

10.2.2 Power head parts list

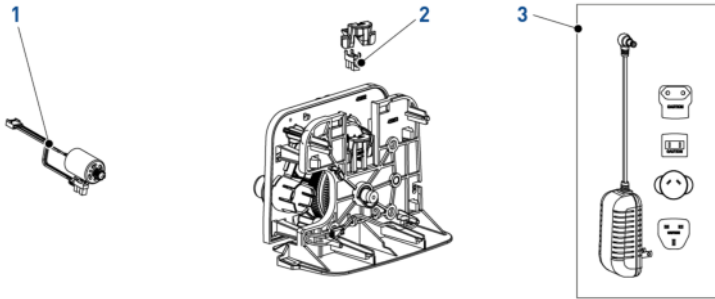

Item	Part number	Description	Package quantity
1	BR61835	Motor assembly, 5800	1
2	1235373	Optical sensor, module photo interrupter sensor Logix	1
3	BR44162	Transformer, international, 230VAC-12VDC, 5800	1

10.2.3 Paddle meter parts list

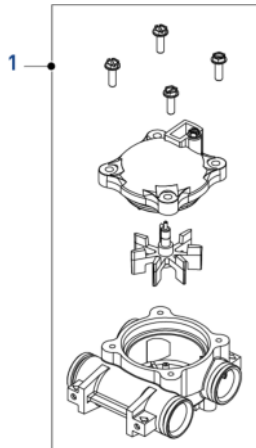

Item	Part number	Description	Package quantity
1	26702	Meter assy 3/4" Electronic	1

10.3 Piping

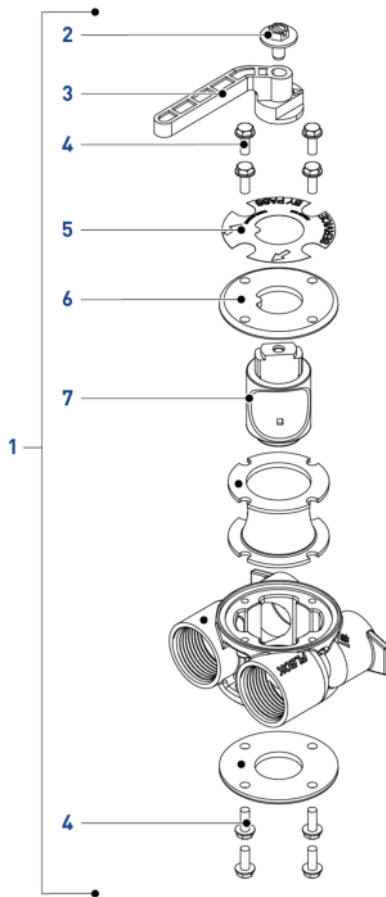

Item	Part number	Description	Package quantity
1	BU28502	Bypass Stainless Steel 1" BSP	1
2	13386SP	Screw Hex Hd Mach 1/4-20 X 1 Or Slot Hex	10
3	N/A	Bypass handle red	10
4	N/A	Screw, Hex washer head 10-24 x 0.5"	8
5	N/A	Label bypass standard	1
6	N/A	Cover bypass, Top	1
7	N/A	Plug, bypass	1

11 Disposal

The device must be scrapped in accordance with directive 2012/19/EU or the environmental standards in force in the country of installation. The components included in the system must be separated and recycled in a waste recycling center that conforms with the legislation in force in the country of installation. This will help to reduce the impact on the environment, health, safety and help to promote recycling. Pentair does not collect used product for recycling. Contact your local recycling center for more information.



Notes

WWW.PENTAIR.EU