

FOLEO

Smart softener



- ▶ Programming the device can be done via your smartphone.
- ▶ Monitor your water softener and water usage from a distance.
- ▶ Receive an alert when your salt needs refilling.





FOLEO 5800 XTRI

Smart softener

10L / 15L / 20L / 30L



Integrated Stainless steel By-Pass

Simplified and faster initial installation on the inlet and outlet pipe connections: no more expensive, complicated and cumbersome wall pipe bypass.

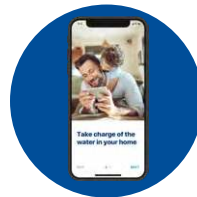

Smart connectivity

This softener features wifi and Bluetooth® wireless technology to sync with the Pentair Home app and the Pentair Pro app.



Smart tilting salt lid opening

The ergonomic and easy to open salt lid transforms the salt recharge process from a painful operation into an easier and faster one.

FEATURES

- ▶ Assembled with 100% Pentair components
- ▶ Features Fleck 5800 XTRi variable brining valve, upflow regeneration
- ▶ Large, touch screen display
- ▶ Easy access to settings with the new electronic mounted on cabinet cover
- ▶ Inlet/Outlet connections: 1 inch – BSPT, female
- ▶ Drain line connection: ½ inch – BSPT, male
- ▶ Removable salt compartment
- ▶ The Pentair Home app provides homeowners with instant status information and remote monitoring all of connected Pentair water devices, anytime, from anywhere. For peace of mind at their fingertips.
- ▶ The Pentair Pro app sends alerts to monitor customers' devices in real-time to the pro, to help diagnose issues and save time on service calls.
- ▶ Power requirements: 220 VAC/50 Hz
- ▶ Water pressure range: 1.5-8 bar
- ▶ Water temperature range: 2-38°C
- ▶ High quality acid cationic strong resin
- ▶ Cabinet body: made in polyethylene high density
- ▶ HP Cover: made in ABS
- ▶ Certifications: CE, ACS, DM25
- ▶ All raw materials are RoHs Reach certified

TECHNICAL SPECIFICATIONS

Characteristics	Foleo 10	Foleo 15	Foleo 20	Foleo 30
Part number	4000116W	4000117W	4000118W	4000119W
Resin volume (L)	10 L	15 L	20 L	28 L
Number of people	1-2	3-4	5-6	7-8
Nominal flow rate (m ³ /h) (residual hardness 0 ^o f)	0.60 m ³ /h	0.90 m ³ /h	1.20 m ³ /h	1.68 m ³ /h
Nominal flow rate (m ³ /h) (residual hardness 5-10 ^o f)	0.72 m ³ /h	1.08 m ³ /h	1.44 m ³ /h	2.02 m ³ /h
Peak flow rate (m ³ /h) (residual hardness 5-10 ^o f)	1.00 m ³ /h	1.50 m ³ /h	2 m ³ /h	2.80 m ³ /h
Salt dosage g/resin (standard settings)	80 g/l	80 g/l	80 g/l	80 g/l
Salt consumption per regeneration (kg)	0.8 kg	1.2 kg	1.6 kg	2.24 kg
Water consumption per regeneration (L)	42 L	48 L	77 L	99 L
Softener capacity °f x m ³	48.4 °f • m ³	72.6 °f • m ³	96.8 °f • m ³	135.52 °f • m ³
Capacity in m ³ for 30 ^o f inlet water hardness and 10 ^o f residual hardness setting	2.42 m ³	3.63 m ³	4.84 m ³	6.78 m ³
Maximum yearly salt savings % versus a standard <i>Regenerating with 80 g/Resin calendar override set on 4 days. Reserve at 20%. softener</i>	50%			
Stainless steel bypass	included			
Removable salt compartment	included			
Salt compartment capacity (kg)	15 kg	15 kg	25 kg	25 kg
System interface	Touch screen monitor			
Packaging dimension (WxLxH) mm	400x600x760		400x600x1200	
Product weight	12 kg	18 kg	24 kg	35 kg
Packaging dimension (WxLxH) mm	360x456x750		360x456x1045	
Quantity per pallet	10		5	
Pallet dimensions (WxLxH) mm	1000x1200x1720		1000x1200x1400	

Note: This example is calculated for a salt dosage for 80 g/L resin. Should the inlet hardness be greater than 30°F it may be required to increase the salt dosage to obtain proper resin bed regeneration. The same simulation with 120 g/L resin led to an estimated average salt saving of 35.5%, while the same simulation done at 160 g/L led to an estimated salt saving of 50%.
 * Foleo is featured with variable refill therefore the salt quantity required is calculated by the controller at each regeneration start. This maximum amount corresponds to cases where 100% of the capacity would have been exhausted or to what a standard softener without variable refill would consume.
 ** The Foleo Smart Softener automatically calculates the exchange capacity based on standard efficiency values each time the system is powered up after being disconnected for long period of time. The values showed in this techsheet are not the default ones but could be achieved under specific conditions (hardness lower than 30 °F) and the Foleo is set to those values during startup.



OUTLINE DRAWINGS

Foleo 10L-15L

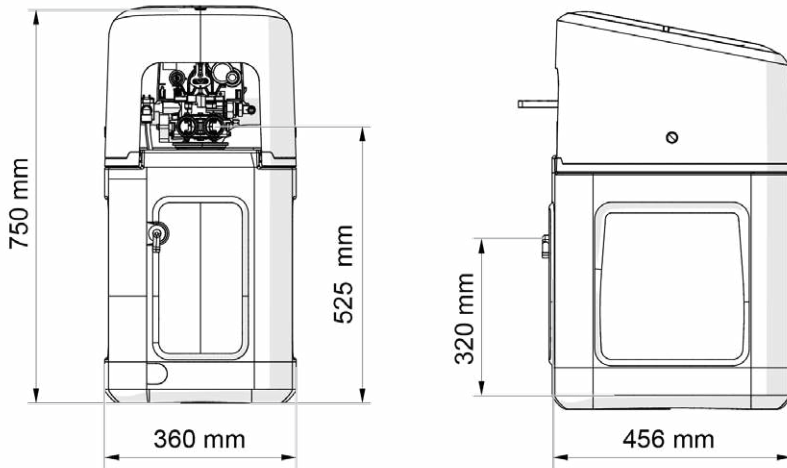

Foleo 20L-30L

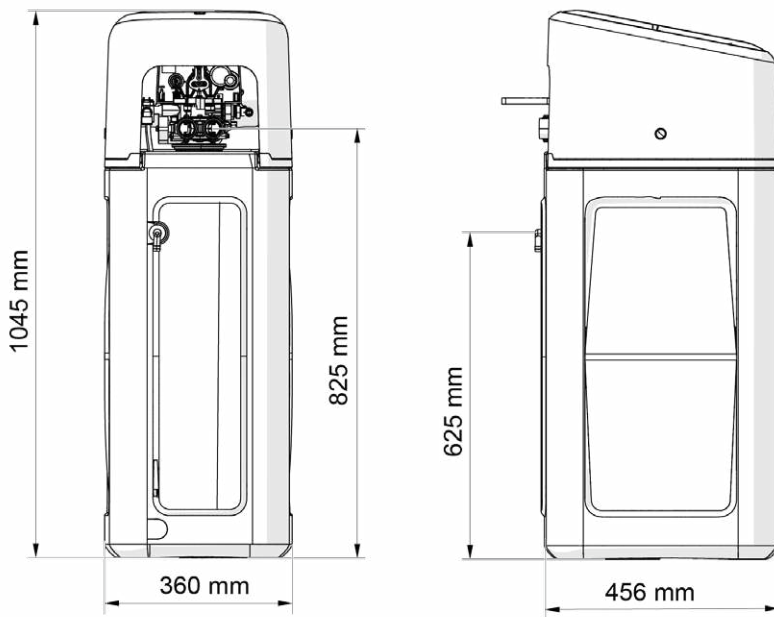

www.pentair.eu

All indicated Pentair trademarks and logos are property of Pentair. Third party registered and unregistered trademarks and logos are the property of their respective owners. Apple App Store® is a registered trademark of Apple, Inc. Google Play™ is a registered trademark of Google, LLC. The Bluetooth® word mark and logos are registered trademarks owned by Bluetooth SIG, Inc. and any use of such marks by Pentair is under license.