

INSTRUCTION MANUAL

F2000-B2B, F2000-B2M
FILTRATION SYSTEMS

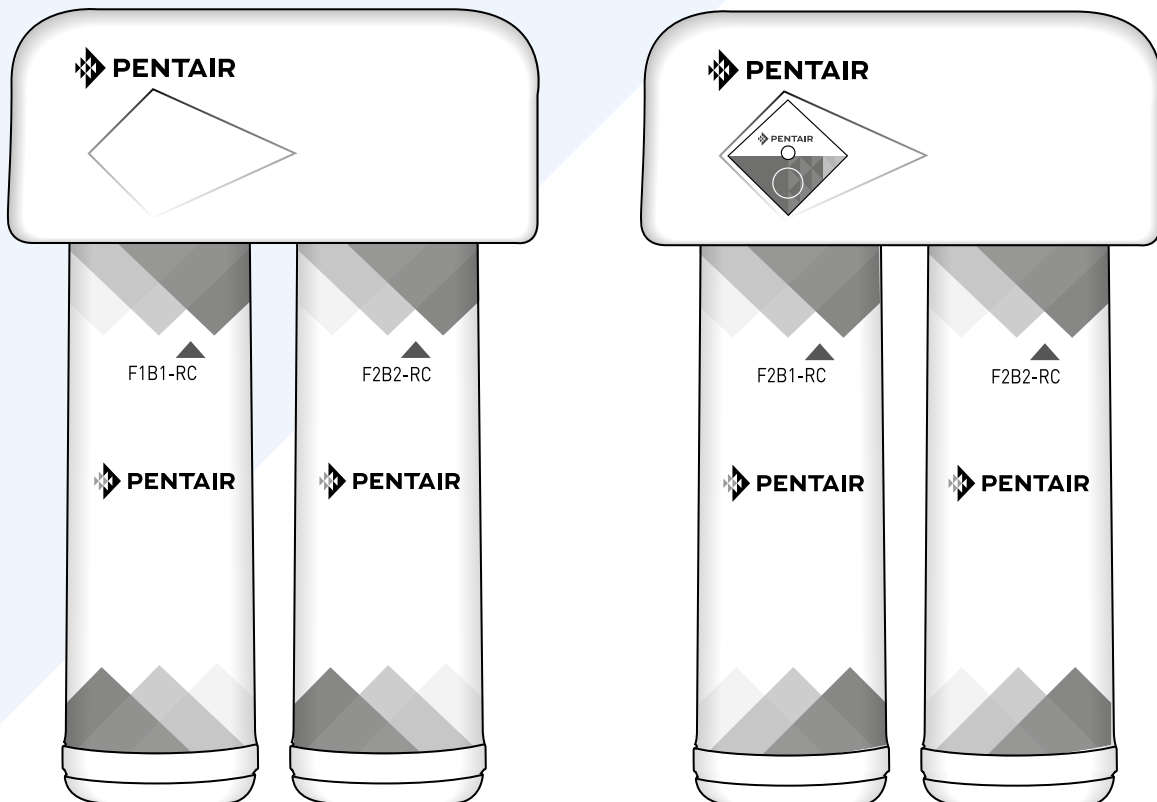

SPECIFICATIONS

Temperature range:..... 4,4-37,8°C
Pressure range:2,75-6,89 bar
Service flow rate @ 4,1 bar:
Model: F2000-B2B 2,27 Lpm
Model: F2000-B2M 2,27 Lpm
Rated service life:
Model: F2000-B2B 2'555 L
Model: F2000-B2M 2'555 L
Dimensions:317mm x 203mm x 133mm
(12,5" x 8" x 5,25")

Weight:

Model: F2000-B2B (system only)..... 2 kg
Model: F2000-B2M (system only) 2 kg

PARTS INCLUDED

- Filter system with cartridges
- Installation hardware kit
- Lead-free drinking water faucet
- 3/8" (white and blue) plastic tubing

PRECAUTIONS

⚠ WARNING Do not use with water that is microbiologically unsafe or of unknown quality without adequate disinfection before or after the system. Systems certified for cyst reduction may be used on disinfected waters that may contain filterable cysts. Chemical and mechanical reduction unit.

⚠ CAUTION System must be protected against freezing, which can cause cracking of the filter and water leakage.

NOTE:

- For cold water use only.
- Make certain that installation complies with all state and local laws and regulations.
- The system must be maintained according to manufacturer's recommendations, including replacement of filter cartridges. The contaminants or other substances removed or reduced by the selected cartridge are not necessarily in your water. Ask your local water municipality for a copy of their water analysis, or have your water tested by a reputable water testing lab.
- After prolonged periods of non-use (such as during a vacation) it is recommended that the system be flushed thoroughly. Let water run for 5-6 minutes before using.
- The filter cartridges used with this system have a limited service life. Changes in taste, odor, and/or flow of the water being filtered indicate the cartridge should be replaced.

TOOLS AND MATERIALS REQUIRED

- Safety glasses
- Adjustable wrench
- Tube cutter or utility knife
- Hand or electric drill (cordless recommended)
- File
- 1/4" drill bit

If sink does not have hole for separate faucet:

- Center punch
- 3/4" drill bit or hole saw
- 3/32" drill bit

CARTRIDGE SEQUENCE

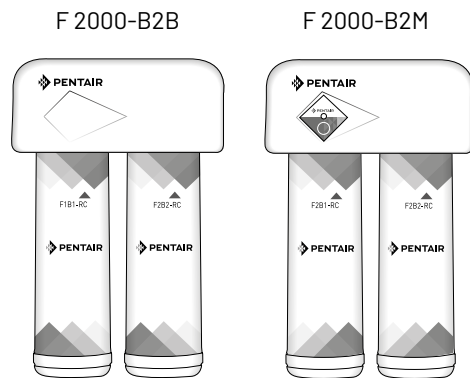

INSTALLATION

NOTE:

- For standard under-sink installation on 1/2" 14 NPS threads or 3/8" x 3/8" compression
- Please read all instructions and precautions before installing and using your filtration systems
- Numbered diagrams correspond with numbered steps

1. Installing the water supply adapter

The supply adapter fits 1/2"-14 NPS supply threads or 3/8" x 3/8" compression. If local codes permit, it may be used to connect the system to the cold water supply line. If local codes do not permit the use of the supply adapter, alternate connectors can be obtained from your local supplier.

- Turn off cold water supply line. If cold water line does not have a shut-off valve under the sink, you should install one.
- Turn on the cold water faucet and allow all water to drain from line.
- Disconnect riser cold water supply valve.
- Ensure the sealing gasket is fully seated into the feed adapter valve female thread.
- Install feed adapter valve onto supply valve. Hand tighten only.
- Connect the riser to the feed adapter valve.

NOTE: See figures 1G-1H for configuring the feed adapter to 3/8" x 3/8" compression connections.

2. Selecting the faucet location

NOTE: The drinking water faucet should be positioned with function, convenience, and appearance in mind. An adequate flat area is required to allow faucet base to rest securely. The faucet fits through a 3/4" hole. Most sinks have pre-drilled 1-3/8" or 1-1/2" diameter holes that may be used for faucet installation. If these pre-drilled holes cannot be used or are in an inconvenient location, it will be necessary to drill a 3/4" hole in the sink to accommodate the faucet.

CAUTION This procedure may generate dust which can cause severe irritation if inhaled or come in contact with the eyes. The use of safety glasses and respirator for this procedure is recommended.

CAUTION DO NOT ATTEMPT TO DRILL THROUGH AN ALL-PORCELAIN SINK. If you have an all-porcelain sink, mount the faucet in pre-drilled sprayer hole or drill through countertop next to sink.

CAUTION When drilling through a countertop, make sure the area below the drilled area is free of wiring and piping. Make certain you have ample room to make the proper connections to the bottom of the faucet.

CAUTION Do not drill through a countertop that is more than 1" thick.

CAUTION Do not attempt to drill through a tiled, marble, granite or similar countertop. Consult a plumber or the countertop manufacturer for advice or assistance.

- Line bottom of sink with newspaper to prevent metal shavings, parts, or tools from falling down the drain.
- Place masking tape over the area to be drilled to prevent scratches if drill bit slips.
- Mark hole with center punch. Use a 1/4" drill bit to drill pilot hole.
- Use a 3/4" drill bit and drill a hole completely through sink.
- Smooth rough edges with a file.

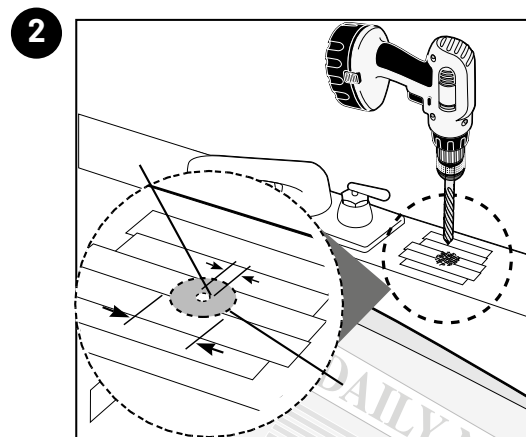
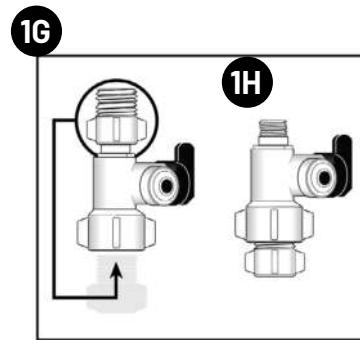
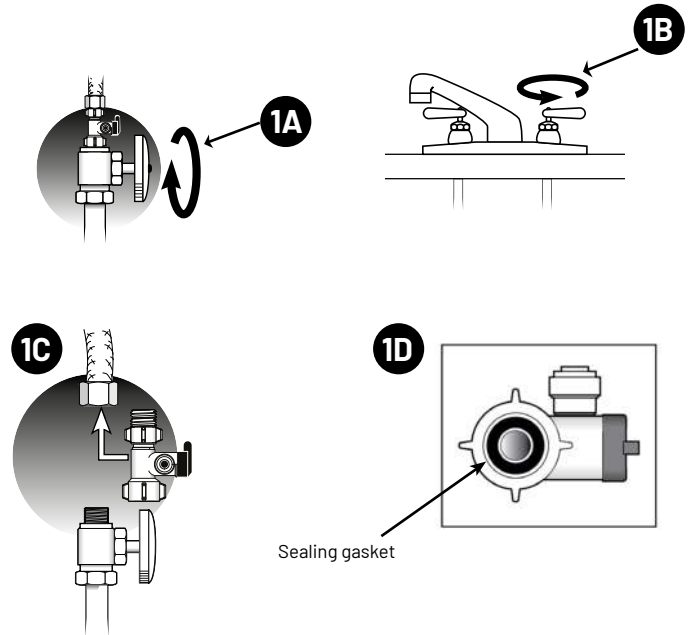

INSTALLATION CONTINUED

3. Mounting the faucet

- A. Apply 3-5 wraps of plumber tape to faucet stem.
- B. Assemble faucet as shown in figure 3.
- C. Screw quick connector onto threaded end of faucet stem.
- D. Place a mark 5/8" from one end of the blue tubing. Wet the end of the 3/8" tube and push into bottom of connector. The 5/8" mark should be flush with the collar of the connector.

NOTE: To remove the tube, push on the fittings' collar and pull the tube out.

- E. Holding the faucet, feed the tubing through the hole in the sink. Position the faucet handle at a desired location.
- F. Center the faucet and slip slotted disc between the bottom of the counter or sink and lock washer. Tighten the stem nut with a wrench until it is tight.
- G. Firmly insert spout into faucet base.

4. Mounting the system

- A. Select a location under the sink, or other suitable area where the system will be installed.

NOTE: The system carton can be used to determine the operational footprint required for installation of the system and replacement cartridges. (figure 4a)

- B. Mount the system vertically. Ensure mounting is level. Place a pencil mark in the upper slots of the bracket mounting holes. (figure 4b). Alternate mounting option: If mounting the system near the floor, place the pencil marks above each of the mounting holes on the bracket to ensure enough space resides below the cartridge and the floor for cartridge replacement (figure 4c). Use the 3/32" drill bit to create pilot holes for mounting.

⚠ WARNING The system should be mounted to a firm, solid surface that is able to support the weight of the system.

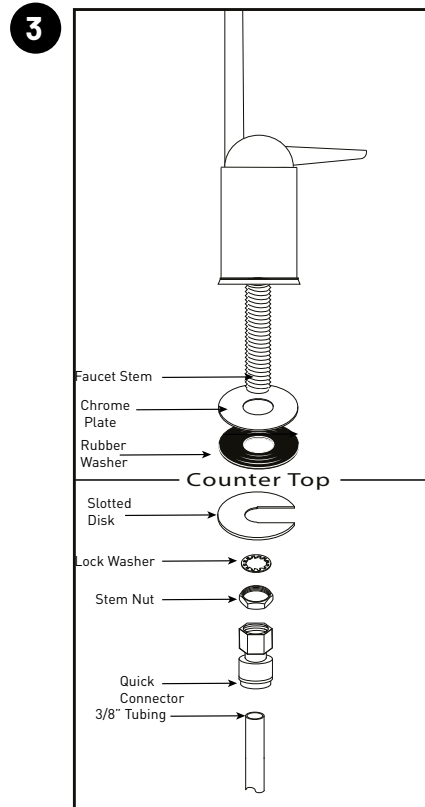

4a

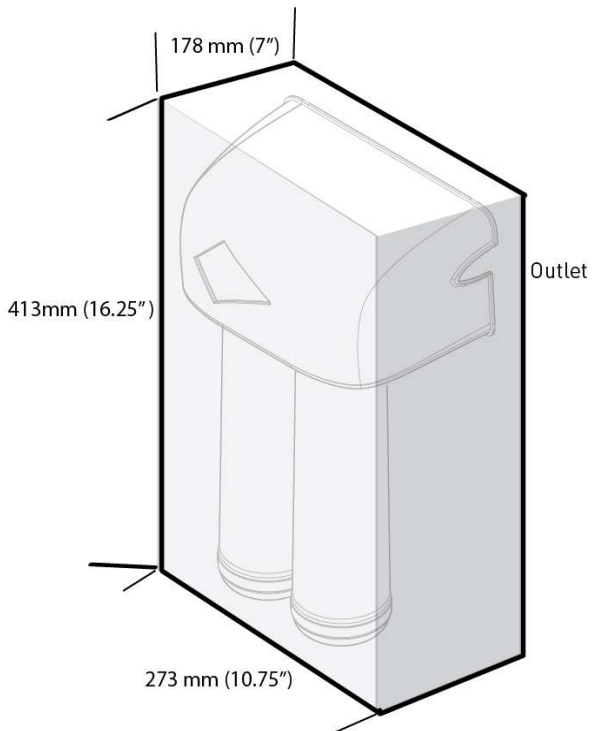

4b

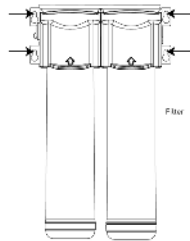

4c

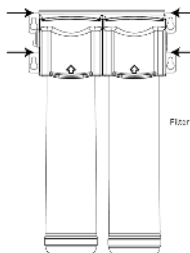

INSTALLATION CONTINUED

5. Connecting the faucet to the system

- A. Determine the length of plastic blue tubing needed to connect to the outlet (right) side of the filter from the faucet. Be sure to allow enough tubing to prevent kinking and cut the tubing squarely. Use a marker to mark one end of the tubing 5/8" from the end (figure 5). Wet the end of the 3/8" tube and push into the outlet (right) connection of the system up to the mark.

CAUTION Do not bend or crimp tube inserting.

- B. Gently pull back on the tube to ensure it is connected properly.

6. Connecting the supply adapter

- A. Determine the length of plastic white tubing needed to connect the inlet (left) side of the filter with the feed adapter installed on the cold water supply line. Be sure to allow enough tubing to prevent kinking and cut the tubing squarely. Place a mark 5/8" from one end of the tubing. Wet the end of the tubing. Insert the end of the tubing into the 3/8" fitting of the inlet supply adapter. The 5/8" mark should be flush with the collar of the fitting located on the inlet supply adapter (figure 6a).
- B. Mark the remaining end of the tubing. Use a marker to mark 5/8" from the end. Wet the end of the tube. Insert the end into the feed connection on the inlet side (left) of the system. The tube should go in up to the mark. (figure 6b).

7. Placing the system into operation

- A. Slowly turn on the cold water supply. Ensure that the feed adapter valve is also open.
- B. Open faucet and flush filter for 10 minutes. Discard water.
- C. Check for leaks at all fittings before leaving installation. If leaks appear, see troubleshooting.

NOTE: A drinking water cartridge may contain carbon fines (very fine black powder). If carbon fines appear in the water, discard water. More flushing is required if carbon fines are present.

NOTE: Initially, filtered water may appear cloudy. If cloudiness in a glass of water disappears from the bottom; fine air bubbles are present. This air within the water will disappear within a few weeks after installation.

INSTALLATION IS NOW COMPLETE.

5



6a

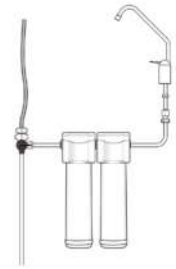

6b

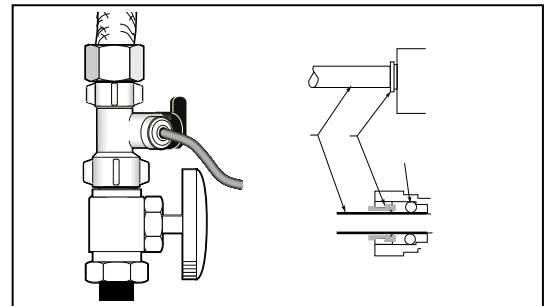

7

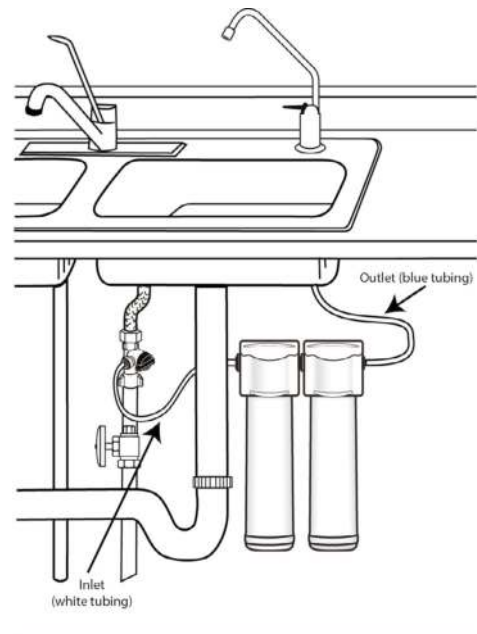

FILTER CARTRIDGES REPLACEMENT

NOTE: The life of the filter cartridges depends on water volume used and the quality of the feed water. It is recommended that the filter cartridges be replaced every 6-12 months, or when there is a noticeable change in taste, odor, or flow of filtered water.

Ensure the correct cartridge set is purchased for the system.

Model F2000-B2B and F2000-B2M use F2B2-RC2 replacement cartridge set

8. Cartridge replacement

- A. Relieve pressure by turning off the water supply to the system and opening a faucet until water flow stops. Place a bucket or towel under the system to catch any water drips (figure 8a).
- B. Remove the cover and lift the locking bar upward until the filter cartridge disengages from the filter head assembly (figure 8b).
- C. Pull the cartridge away from the filter head assembly (figure 8c).
- D. Ensure the locking bar is fully in the up position (figure 8c).
- E. Align the posts on the filter cartridge with the ports in the filter head assembly. Slide the cartridge filter towards into the filter head assembly engaging with the locking bar causing it to drop forward and down. (figure 8d).
- F. Pull down the locking bar until it snaps into place (figure 8e).
- G. Install cover.

NOTE: See placing the system into operation section for remaining steps.

TROUBLESHOOTING

Leaks between filter head assembly and filter cartridge

1. Relieve pressure by turning off the water supply to the system and opening faucet until water flow stops. Place a bucket or towel under the system to catch any water drips.
2. Remove cartridge and inspect O-rings to make sure they are seated and clean.
3. Install filter cartridge. Place system into operation and check for leaks. If leaks persist, turn off the water supply and contact your distributor.

Leaks from tubing fittings

1. Relieve pressure by turning off the water supply to the system and opening faucet until water flow stops. Place a bucket or towel under the system to catch any water drips.
2. Depress collet on system or inlet supply adapter tubing fittings and pull tubing from fitting. Inspect surface of tubing for scratches or debris. Clean or cut back tubing to access clean surface.
3. Wet the end of the inlet tubing and press into the inlet fitting of the system. Ensure the tubing is fully pushed past the fitting O-rings. Place system into operation and check for leaks. If leaks persist, turn off the water supply and contact your distributor.

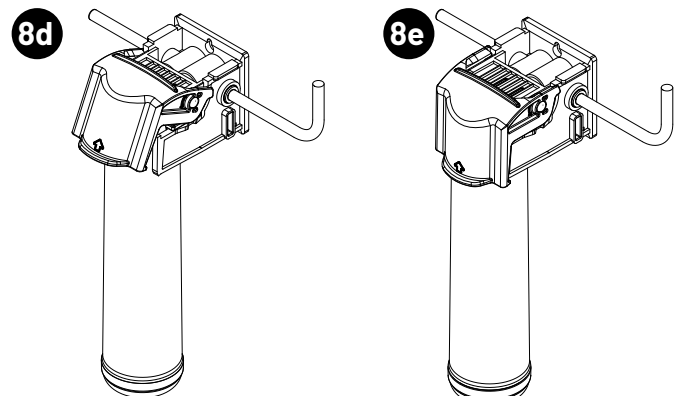
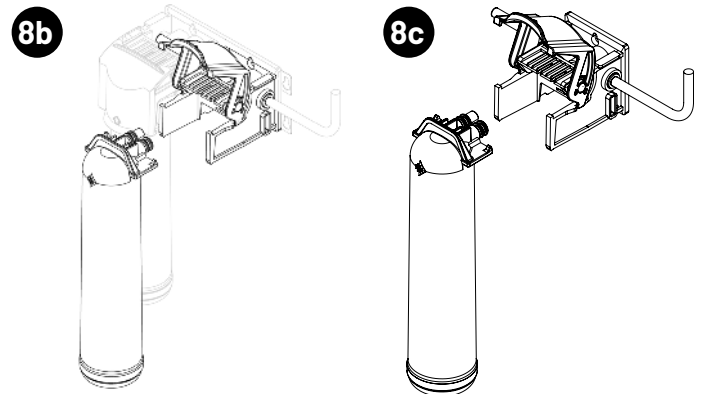
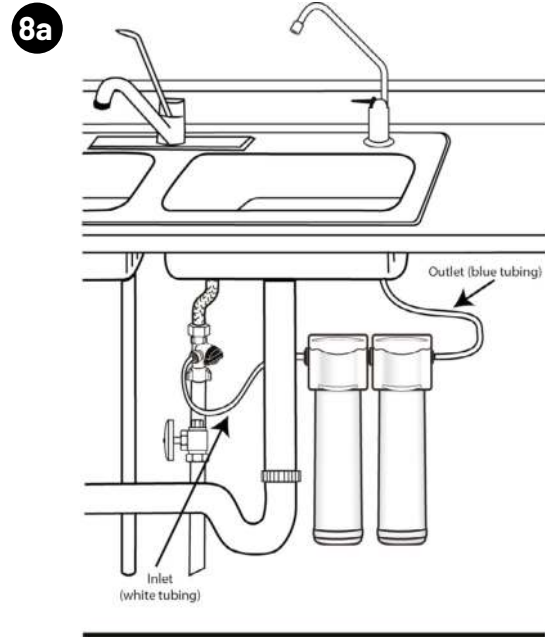

CARTRIDGE TIMER PROCEDURE

FILTER CARTRIDGE TIMER

(MONITORED SYSTEMS ONLY)

The filter cartridge timer can be installed to the systems decorative cover by peeling away the adhesive backing on the metal plate included with the cartridge timer. The timer can also be attached to a metal magnetic surface using the magnet that is factory installed on cartridge timer.

INSTALLATION AND ACTIVATION

Once the installation location has been selected, activate the timer by pulling the plastic tab out from the side of the timer. Press and release the key to verify the battery is operational. The light will blink green three times. (figure 9a)

NOTE: The timer operates on 12 month schedule. The timer uses a coin cell type 2023 battery.

The filter cartridge timer is operational

Operation

1. The timer will begin to blink red once every three minutes after 11 months, and will blink red three times every three minutes after 12 months. (figure 9b)

NOTE: Timer status of the cartridge life can also be viewed immediately by pressing and releasing the key.

Reset timer

1. To reset the timer after filter cartridge replacement, press the key and hold for 5 seconds. The timer is now reset to 12 months. (figure 9c)

Battery replacement

1. Replace the battery every 12 months. To replace the battery, locate the slot on the side of the timer body and carefully remove the front of the timer. The battery is now accessible. (figure 9d)
2. Slide the new battery under the battery retention bracket with the positive + side of the battery facing up towards the battery retention bracket. Align the tab on the timer back to the slot on the timer front and press and snap both timer halves together. Battery replacement will not reset the 12 month timer. If reset is required, press and hold key for 5 seconds.

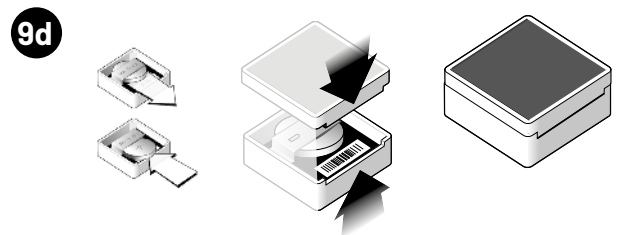
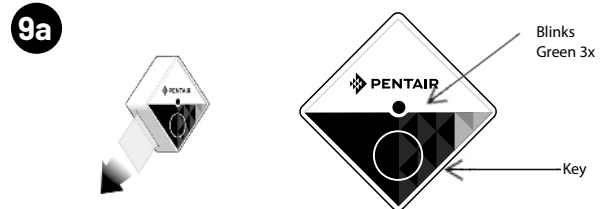
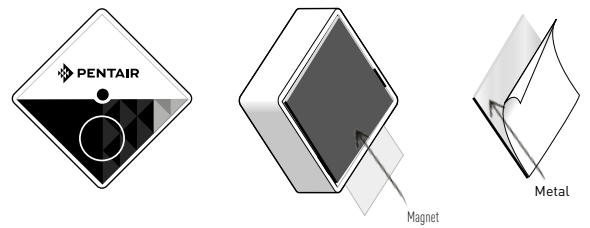

REPLACEMENT PARTS

| ITEM NUMBER | PART NUMBER | DESCRIPTION | QUANTITY REQUIRED |
|-------------|--------------|---------------------------------|-------------------|
| 1 | 655126-96 | Cartridge set, F2B2-RC2 | 1 |
| 2 | 4004603 | Filter head, model F2000-B2B | 1 |
| | 4004605 | Filter head, model F2000-B2M | 1 |
| 3 | 4003596 | Installation kit 2 & 3 stage | 1 |
| 4 | 244960* | Faucet | 1 |
| 5 | 4003530 | Cover, 2 stage | 1 |
| 6 | 4003641-EMEA | Cartridge timer without battery | 1 |

*Image may be different than actual faucet

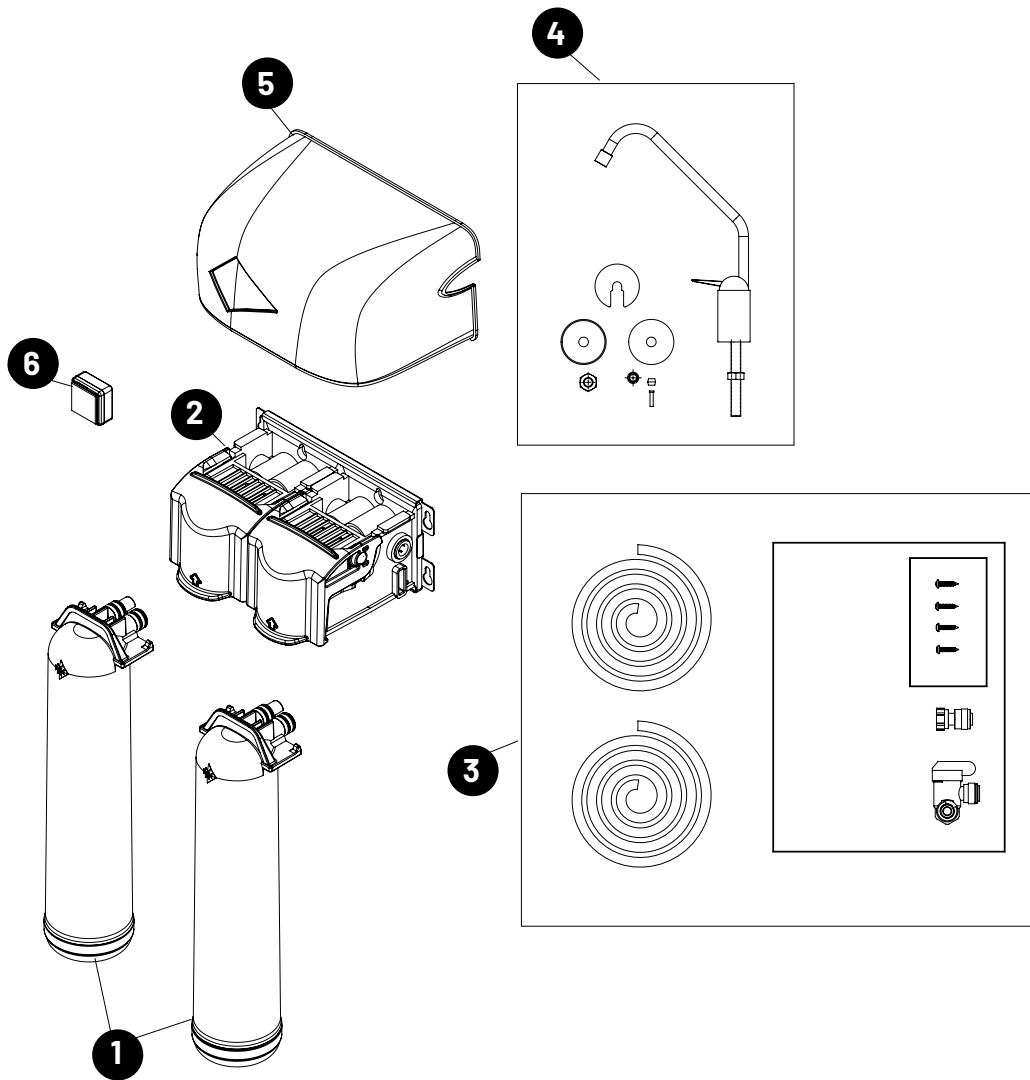

For replacement parts, contact your nearest Pentair distributor.

PERFORMANCE DATA

Important notice: read performance data and compare the capabilities of the system with your actual water treatment requirements. It is recommended that the supply water be tested, before installing a water treatment system, to determine your water treatment needs.

Test conditions

| | | |
|-----------|-----------|------------|
| Flow rate | | |
| | F2000-B2B | = 2,27 Lpm |
| | F2000-B2M | = 2,27 Lpm |

Filter capacity

| | |
|----------------|------------------|
| F2000-B2B | = 2'555 L |
| F2000-B2M | = 2'555 L |
| Inlet pressure | = 4,1 bar |
| Temperature | = 20°C +/- 2,5°C |

Testing was performed under standard laboratory conditions, actual performance may vary,

Operating requirements for F2000-B2B and F2000-B2M systems:

| | |
|-------------|-----------------|
| Pressure | = 2,75-6,89 bar |
| Temperature | = 4,4-37,8°C |

F2000-B2B, F2000-B2M SYSTEMS INSTALLED WITH F2B2-RC FILTER CARTRIDGE SET

This system has been tested according to NSF/ANSI 42 and 53 for reduction of the substances listed below. The concentration of the indicated substances in water entering the system was reduced to a concentration less than or equal to the permissible limit for water exiting the system, as specified in NSF/ANSI 42 and 53.

Conforms to NSF/ANSI 53. See performance data sheet for individual contaminant and reduction performance.

Model F2000-B2B, F2000-B2M systems

| Substance | Influent challenge concentration | Max. permissible product water concentration | Reduction requirements | Minimum reduction | Average reduction |
|-----------------------------------|----------------------------------|--|------------------------|-------------------|-------------------|
| Standard 42 | | | | | |
| Chlorine taste & odor | 2,0 mg/L ± 10% | | ≥ 50% | | 95,9% |
| Particulates (0.5- <1µM) class 1* | at least 10'000 particulates/mL | | > 85% | | 97,9% |
| Standard 53 | | | | | |
| Cysts** | minimum 50'000/L | | 99,95% | 99,97% | 99,99% |
| Atrazine | 0,009 mg/L ± 10% | 0,003 mg/L | | 90,5% | 93,7% |
| Lead (pH 6.5) | 0,15 mg/L ± 10% | 0,010 mg/L | | 99,3% | 99,9% |
| Lead (pH 8.5) | 0,15 mg/L ± 10% | 0,010 mg/L | | 99,3% | 99,6% |
| Lindane | 0,002 mg/L ± 10% | 0,0002 mg/L | | 94,8% | 97,4% |

Flow rate = 2,2 Lpm; capacity = 2'555 L or 12 months

Testing was performed under standard laboratory conditions, actual performance may vary.

* Reduces particles as small as 0,5-1 micron in size by mechanical means

** NSF/ANSI Standard 53 certified to reduce cysts such as Cryptosporidium and Giardia by mechanical means.



The Model F2000-B2B and F2000-B2M are Tested and Certified by NSF International against NSF/ANSI Standard 42, 53, and CSA B483.1 for the reduction of substances specified on the Performance Data Sheet.

The models F2000 and F3000 are certified by IAPMO R&T against NSF/ANSI 53 for the reduction of total PFAS.**

**The test mixture for Total PFAS is made up of PFOA (500 ppt), FOS (1,000 ppt), PFHxS (300 ppt), PFNA (50 ppt), PFHpA (40 ppt), PFBS (260 ppt), and PFDA (10 ppt). This system meets the 20 ppt requirement for Total PFAS.





www.pentair.eu

Pentair trademarks and logos are owned by Pentair plc or its affiliates. For a detailed list of where Pentair trademarks are registered, please visit www.pentair.com/en/registrations.html. Third party registered and unregistered trademarks and logos are the property of their respective owners. Because we are continuously improving our products and services, Pentair reserves the right to change specifications without prior notice.

MKT-MA-002-EN-B ©2025 Pentair Filtration Solutions, LLC. All Rights Reserved.