

INSTALLER MANUAL

PRF-RO
REVERSE OSMOSIS
SYSTEM

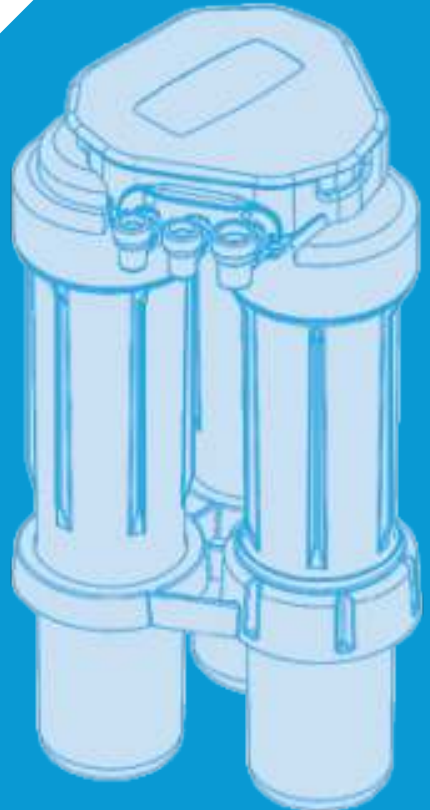

RESIDENTIAL

Table of Contents

1	Generalities	4
1.1	Scope of the documentation	4
1.2	Release management	4
1.3	Manufacturer identifier, product	4
1.4	Intended use	4
1.5	Procedure for technical support	4
1.6	Copyright and Trademarks	5
1.7	Limitation of liability	5
2	Safety.....	6
2.1	Safety pictograms definition	6
2.2	Hazards	6
2.2.1	Personnel	7
2.2.2	Material	7
2.3	Hygiene.....	7
2.3.1	Sanitary issues	7
2.3.2	Hygiene measures	8
3	Description	9
3.1	The basic Reverse Osmosis System	9
3.2	Minimum and Maximum Operating Conditions.....	9
3.3	Components description	10
3.4	Outline drawing	11
3.5	Location of the PRF-RO system.....	11
3.5.1	Typical under-sink installation	13
3.5.2	Typical basement installation	14
3.5.3	Typical light commercial installation	15
4	Installation	16
4.1	Before installing the PRF-RO System	16
4.2	Tools and Materials Required.....	16
4.3	System.....	16
4.3.1	Cold water supply valve installation	17
4.3.2	Drain adapter installation	17
4.3.3	Faucet installation	17
4.3.4	Tubing connections	18
4.3.5	System installation.....	20
4.3.6	System assembly	22
4.4	Sink.....	23
4.4.1	List of part enclosed	23
4.4.2	Vertical Installation	24

4.4.3	Horizontal Installation.....	26
4.4.4	Not recommended procedure	27
5	Water filling, draining and waterproofness inspection	29
6	Maintenance	30
6.1	Maintenance plan.....	30
6.1.1	Replacement of prefilter and postfilter	30
6.1.2	Replacement of PRF-RO membrane	30
6.2	Parts replacement	30
6.2.1	Operations to do before changing elements	30
6.2.2	Membrane elements replacement	31
6.2.3	Prefilter replacement	32
6.2.4	Postfilter replacement	32
6.2.5	System re-connecting.....	32
6.2.6	Sanitization.....	33
7	TroubleShooting	34
8	Disposal	35

1 Generalities

1.1 Scope of the documentation

The documentation provides the necessary information for appropriate use of the product. It informs the user to ensure efficient execution of the installation, operation or maintenance procedures.

The content of this document is based on the information available at the time of publication. The original version of the document was written in English.

For safety and environmental protection reasons, the safety instructions given in this documentation must be strictly followed.

This manual is a reference and will not include every system installation situation. The person installing this equipment should have:

- training in the water filter installation;
- basic plumbing skills.

This document is available in other languages on <https://www.pentair.eu/product-finder/product-type>.

1.2 Release management

Revision	Date	Authors	Description
A	10.02.2020	BRY	First edition.
B	16.01.2023	BRY/FI	New cover, adding instructions for sanitization, website.
C	12.12.2025	MAG	Update of the manufacturer's address.

1.3 Manufacturer identifier, product

Manufacturer: Pentair International LLC
Via Tiziano 32
20145 Milano (MI)
Italy

Product: PRF-RO Reverse Osmosis System

1.4 Intended use

The device is intended for domestic and light commercial applications use only and it is purpose-built for water filtering.

1.5 Procedure for technical support

Procedure to follow for any technical support request:

1. Collect the required information for a technical assistance request.
 - ⇒ Product identification;

⇒ Description of the device problem.

2. Please refer to TroubleShooting [→Page 34]. If the problem persists contact your supplier.

1.6 Copyright and Trademarks

All indicated Pentair trademarks and logos are property of Pentair. Third party registered and unregistered trademarks and logos are the property of their respective owners.

© 2023 Pentair. All rights reserved.

1.7 Limitation of liability

Pentair Water Treatment products benefit, under specific conditions, from a manufacturer warranty that may be invoked by Pentair's direct customers. Users should contact the vendor of this product for applicable conditions and in case of a potential warranty claim.

Any warranty provided by Pentair regarding the product will become invalid in case of:

- installation done by a non-water-professional;
- improper installation, improper programming, improper use, improper operation and/or maintenance leading to any kind of product damages;
- improper or unauthorized intervention on the controller or components;
- incorrect, improper or wrong connection/assembly of systems or products with this product and vice versa;
- use of a non-compatible lubricant, grease or chemicals of any type and not listed by the manufacturer as compatible for the product;
- failure due to wrong configuration and/or sizing.

Pentair accepts no liability for equipment installed by the user upstream or downstream of Pentair products, as well as for process/production processes which are installed and connected around or even related to the installation. Disturbances, failures, direct or indirect damages that are caused by such equipment or processes are also excluded from the warranty. Pentair shall not accept any liability for any loss or damage to profits, revenues, use, production, or contracts, or for any indirect, special or consequential loss or damage whatsoever. Please refer to the Pentair terms and conditions for more information about terms applicable to this product.

2 Safety

2.1 Safety pictograms definition

DANGER



This combination of symbol and keyword indicates an imminently hazardous situation that will result in serious or fatal injury if not avoided.

WARNING



This combination of symbol and keyword indicates a potentially hazardous situation that can result in serious or fatal injury if not avoided.

CAUTION



This combination of symbol and keyword indicates a potentially hazardous situation that can result in minimal or minor injury if not avoided.

Caution - material



This combination of symbol and keyword indicates a potentially hazardous situation that can result in material damage if not avoided.

Prohibition



Mandatory advice to follow.

Mandatory



Applicable guideline, measure.

Info



Informative comment.

2.2 Hazards

All the safety and protection instructions contained in this document must be observed in order to avoid temporary or permanent injury, damage to property or environmental pollution.

At the same time, any other legal regulations, accident prevention and environmental protection measures, as well as any recognized technical regulations relating to appropriate and risk-free methods of working which apply in the country and place of use of the device must be adhered to.

Any non-observation of the safety and protection rules, as well as any existing legal and technical regulations, will result in a risk of temporary or permanent injury, damage to property or environmental pollution.

2.2.1 Personnel

 CAUTION

Risk of injury due to improper handling!

Only qualified personnel, based on their training, experience and instruction as well as their knowledge of the regulations, safety rules and operations performed, are authorized to carry out necessary work.

2.2.2 Material

This Reverse Osmosis System contains replaceable components (membrane elements). These components are critical for the effective reduction of total dissolved solids and specific contaminants that are listed in the Minimum and Maximum Operating Conditions [->Page 9].

The Reverse Osmosis System works on water pressures of 2.8 bar minimum to 5.5 bar maximum. Water pressure can be reduced by installing a pressure reducing valve in the water supply pipe to the PRF-RO system. A booster pump should be used for low pressure applications.

Do not install the Reverse Osmosis System in extreme hot or cold temperatures. Temperature of the water supply to the Reverse Osmosis System must be between 4°C and 38°C. Do not install on hot water lines.

2.3 Hygiene

2.3.1 Sanitary issues

Preliminary checks and storage

- Check the integrity of the packaging. Check that there is no damage and no signs of contact with liquid to make sure that no external contamination occurred;
- the packaging has a protective function and must be removed just before installation. For transportation and storage, appropriate measures should be adopted to prevent the contamination of materials or the objects themselves.

Use

Do not use this product to make safe drinking water from non-potable water sources. Do not use the system on microbiologically unsafe water, or water of unknown quality without adequate disinfection before or after the system.

The Reverse Osmosis System does not have a monitoring device for contaminants. To verify that the system is performing satisfactorily the product water should be tested periodically by the system's installing dealer or a certified laboratory, every six months. The laboratory should be certified for testing the specific contaminants of concern. For a listing of certified laboratories, contact local regulatory agencies. Within the United States, many state-run Department of Natural Resources or Department of Health Services maintain listings of certified laboratories.

2.3.2 Hygiene measures

Disinfection

- The materials used for the construction of our products meet the standards for use with potable water; the manufacturing processes are also geared to preserving these criteria. However, the process of production, distribution, assembly and installation, may create conditions of bacterial proliferation, which may lead to odor problems and water contamination;
- Maximum cleanliness is recommended during the assembly and installation.

3 Description

3.1 The basic Reverse Osmosis System

Your Reverse Osmosis System is a water treatment unit. It uses water pressure to reverse a natural physical process called osmosis. Water, under pressure, is forced through a semipermeable membrane to filter out minerals and impurities. Treated drinking water goes to the faucet. Minerals and impurities are sent to the drain with PRF-RO waste water.

The system includes replaceable filters and membrane elements. The prefilter reduces sand, silt, dirt, rust particles, other sediments, and chlorine from the water supply before they enter the PRF-RO membrane elements. The postfilter reduces any tastes and/or odors that may remain in the water after passing through the PRF-RO membrane elements.

3.2 Minimum and Maximum Operating Conditions

Condition	Minimum	Maximum
Inlet Pressure	2.8 bar	5.5 bar
Inlet Temperature	4°C	38°C
Inlet TDS	50 mg/L	2,000 mg/L
Inlet Hardness	0 mg/L (0 grain)	171 mg/L (10 grain)
Inlet Chlorine	0 mg/L 1.0 mg/L	1.0 mg/L
Inlet Iron	0 mg/L 0.1 mg/L	0.1 mg/L
Inlet Manganese	0 mg/L 0.05 mg/L	0.05 mg/L
Inlet pH	4	10
Inlet Turbidity	0	1 NTU

3.3 Components description

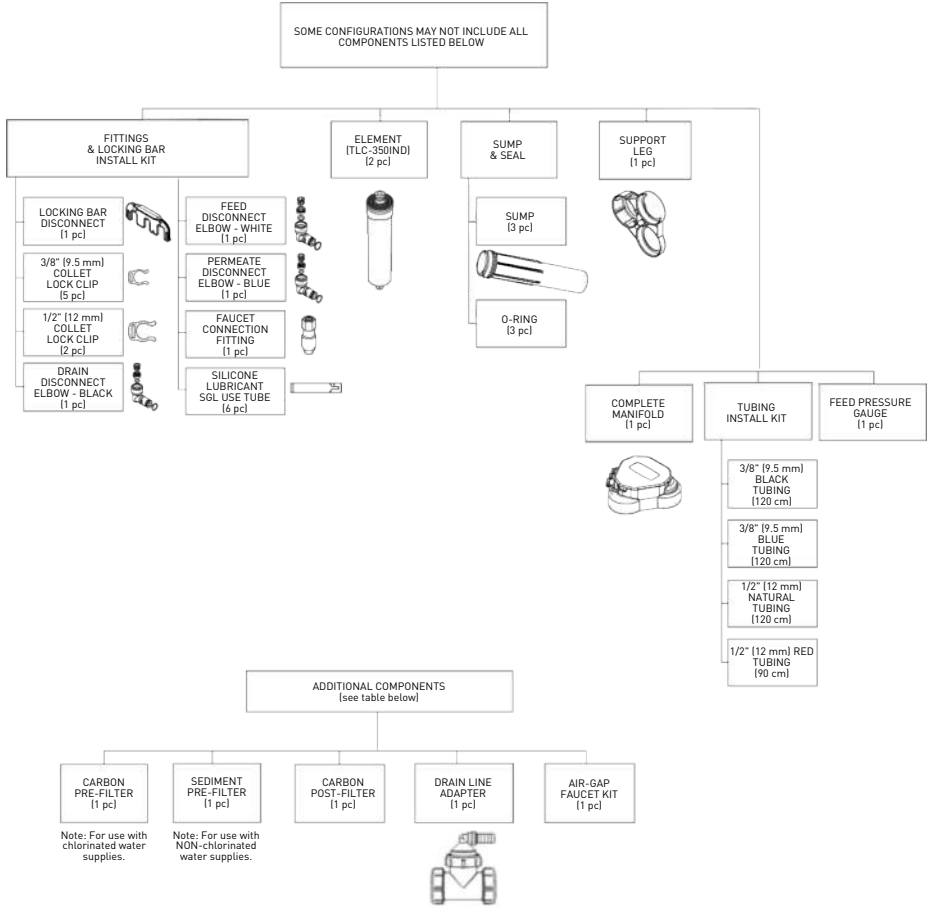

3.4 Outline drawing

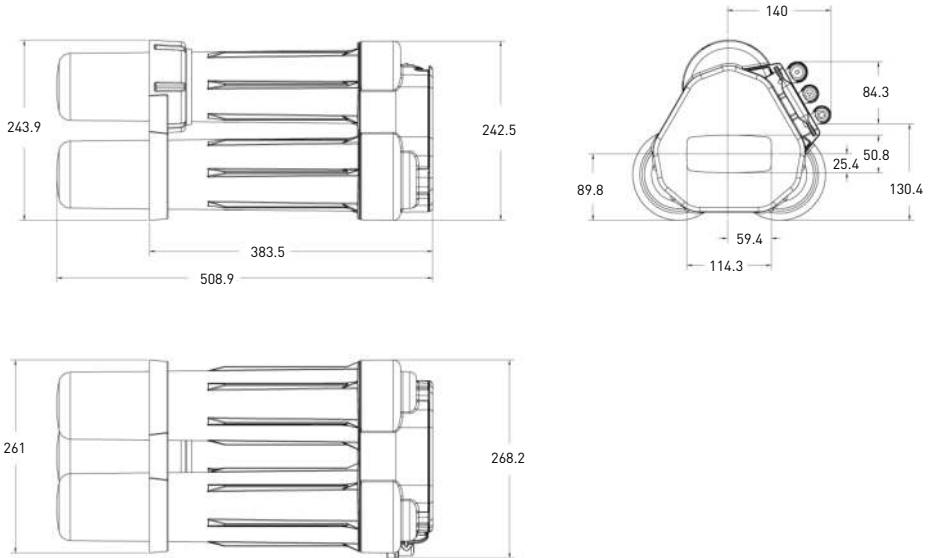

3.5 Location of the PRF-RO system

The Reverse Osmosis System is designed for installation under a sink, usually in the kitchen or bathroom. The PRF-RO assembly can be placed on the cabinet floor in any position that does not apply pressure on the disconnect elbows. The PRF-RO product water faucet installs on the sink or on the countertop next to the sink.

The PRF-RO system can also be located in a location away from the faucet. A nearby water source and drain point are required.

Info



Keep the lengths of tubing short.

Longer lengths of tubing will decrease system performance. A booster pump can be used on the supply line.

Mandatory



All plumbing should be done in accordance with state and local plumbing codes. Some codes may require installation by a licensed plumber. Check with the local plumbing authority prior to installation.

All components and tubing should be located in an area which is not exposed to freezing temperatures. Do not expose unit or tubing to direct sunlight.

Water Supply

To provide supply water to the PRF-RO system inlet, a feed supply fitting is required or install pipe fittings as needed.

The feed water valve should be located as close to the manifold assembly as possible.

Mandatory

Use a potable cold water supply only !

Softened water is preferred as it will extend the life of the PRF-RO membrane element.

Drain Point

A suitable drain point is needed for reject water from the PRF-RO system. A floor drain, laundry tub, standpipe, sump, etc. are all acceptable. If discharging into the utility sink or standpipe, an air gap of greater than 12 mm above the flood rim must be provided. A sink p-trap drain adapter is included to install as an optional drain point where codes permit.

Mandatory

Do not connect the system drain line to the dishwasher drain or near the garbage disposal.

Back pressure from these units may cause the air gap to overflow.

Faucet

The faucet should be placed near the sink where drinking water is normally obtained. Convenience of use (filling of water pitchers and glasses) and an open area beneath the faucet under the sink for attaching product and drain tubing are considerations. A 50 mm diameter flat surface is required above and below the installation site. The thickness of mounting surface should not exceed 30 mm. Avoid any strengthening webbing on the underside of the sink.

PRF-RO Manifold Assembly

The manifold can be installed on either the right or left side of the under-sink area or cabinet. Installation in the basement is also an option. One possible location is near the laundry/utility sink where cold potable water and drain access are close. The location chosen should allow adequate clearance and accessibility for membrane element changes.

In restricted under-sink areas, it may be easier to install the faucet first. Allow adequate tubing lengths for final system placement.

3.5.1 Typical under-sink installation

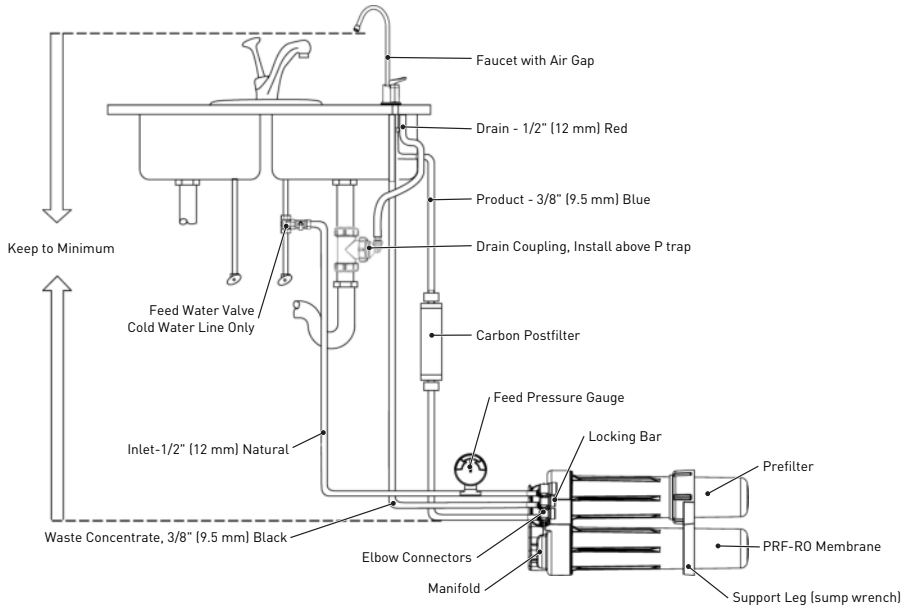

3.5.2 Typical basement installation

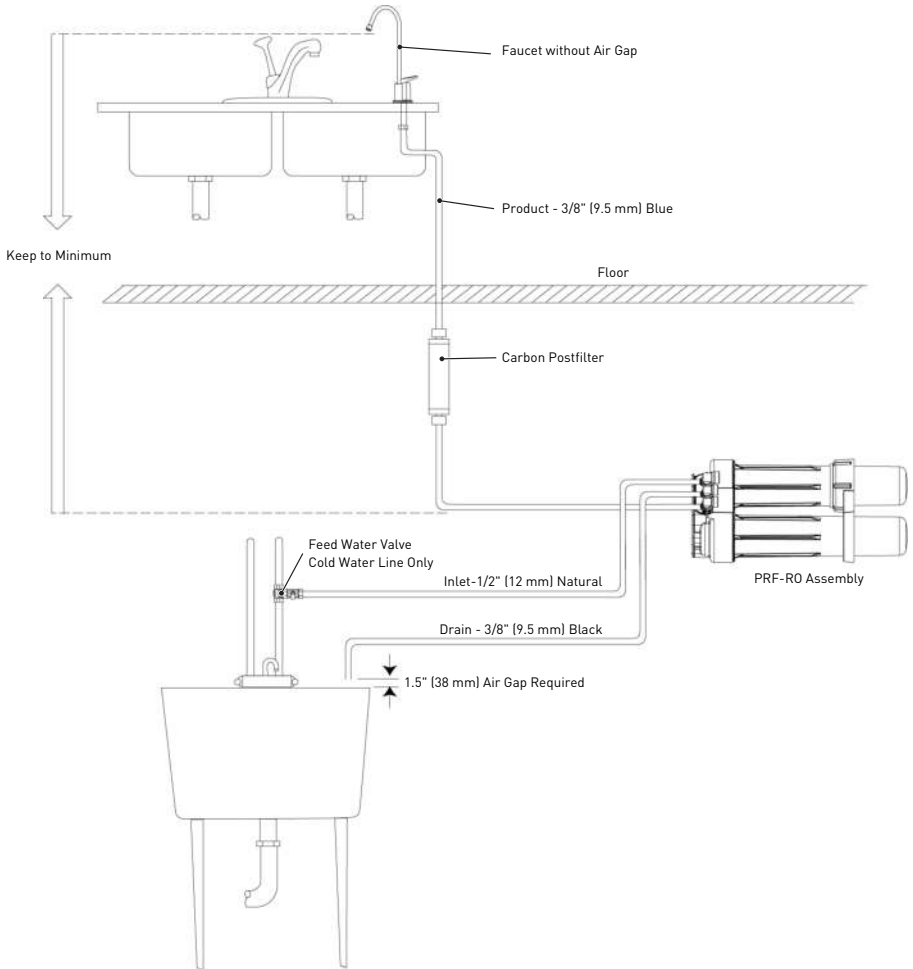

3.5.3 Typical light commercial installation

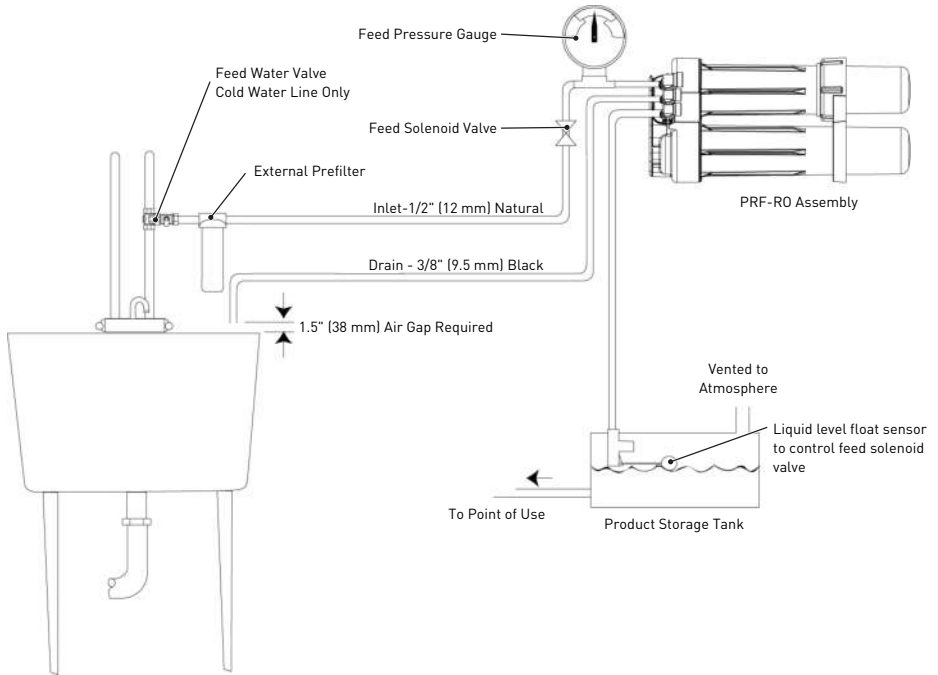

4 Installation

4.1 Before installing the PRF-RO System

- Best performance of the system will be achieved when the incoming water has been treated (softened);
- The water coming into the system must be within certain limits for sediments, pressure, etc. Refer to the specifications to determine if your installation is within the limits;
- A water quality analysis can be performed to determine if incoming water requires any treatment. Contact your dealer/installer;
- The filters and membrane elements in the PRF-RO system need to be replaced on a regular basis. Follow the instructions for replacement that are in this manual. See Parts replacement [→Page 30].

Info



For optimal system performance, use the system for at least 2 minutes continuously each day.

The PRF-RO system is designed to work without the aid of a pressurized storage tank. Installation of a pressurized storage tank will negatively affect system performance.

4.2 Tools and Materials Required

- Adjustable wrench, and larger adjustable jaw pliers or pipe wrench to fit sink drain;
- Saw for cutting drain pipe;
- Slotted and Phillips head screwdrivers;
- Tubing cutters;
- Electric drill and bits for cutting the faucet mounting hole.

Info



Note that some sinks will have a pre-drilled hole with a plug for the faucet.

4.3 System

The installation is divided in six steps:

1. Cold water supply valve installation [→Page 17]
2. Drain adapter installation [→Page 17]
3. Install faucet [→Page 17]
4. Make tubing connections [→Page 18]
5. System installation [→Page 20]
6. System assembly [→Page 22]

Caution - material

Risk of material damages due to wrong handling !

Consult a licensed plumber if you are not familiar with plumbing procedures.

4.3.1 Cold water supply valve installation

A typical connection using a water supply valve is shown in the following figure.

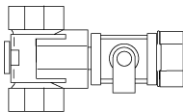

1. Turn off the water supply and open a low faucet to drain the pipe.

Caution - material

Risk of flood due to opened water supply !

2. Due to cold water pipes size and style variations, determine the type of valve to be used.
3. Install a valve on the cold-water supply pipe to adapt 1/2-inch (12 mm) OD tubing. If threaded fittings are used, use pipe joint compound or plumber tape on outside threads.
4. Turn the valve off.

4.3.2 Drain adapter installation

1. If a water drain line adapter is used, follow the Sink [→Page 23] instructions.

Info

The drain adapter is designed to fit 1-1/2-inch (38 mm) sink drain pipe.

2. Install the adapter directly to the sink tailpiece.

4.3.3 Faucet installation

Prepare Mounting Hole

1. Select a location for the faucet. Be sure it will fit flat against the sink or counter and that there is space underneath for tubing.
2. If drilling is needed, make a 1-1/2-inch (38 mm) diameter hole.

Caution - material

Risk of damage due to lack of machining knowledge !

To avoid damaging a sink, consult a qualified plumber or installer for the proper method of drilling holes in porcelain or stainless steel.

Assemble Faucet

The tubing and fasteners are assembled to the faucet before the faucet is placed in position. This can be done above the sink.

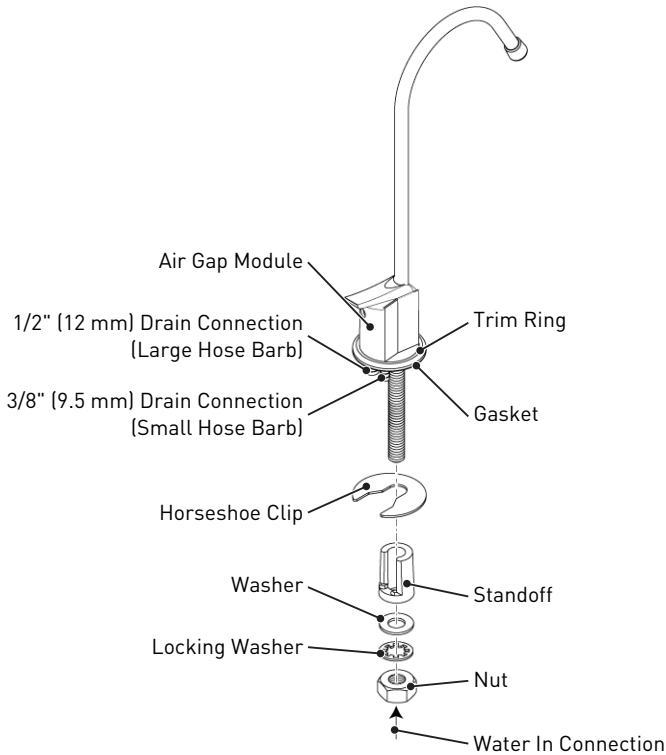

1. Slide the decorative ring over the tubing connections and up to the bottom of the faucet.
2. Slide the gasket over the tubing connections and up to the bottom of the faucet.
3. Slide the standoff onto the threaded tube, followed by the standard washer, the lock washer and nut.
4. Screw the threaded hose connector on the end of the threaded tube.
5. Connect the blue 3/8-inch (9.5 mm) product tubing by firmly pushing it into the connector.
6. Push the black 3/8-inch (9.5 mm) tubing onto the small hose barb. The red 1/2-inch (12 mm) tubing is pushed onto the large hose barb.
7. Put the faucet into position.
8. The horseshoe clip is positioned around the threaded pipe under the sink and above the standoff. This clip should engage the tubing connected to the air gap.
9. Tighten the nut against the clip to hold the faucet in position.

4.3.4 Tubing connections

The connections to the faucet should be complete, the remaining connections are:

- **Feed connection:** clear tubing from feed valve to white elbow connector;
- **Drain connection:** either red tubing from the air gap or black tubing from grey elbow connector will attach to the drain adapter;

- **Permeate connection:** blue tubing from faucet to blue elbow connection;
- **Manifold connection:** fixing fittings to the manifold.

A typical connection is shown in the following figure.

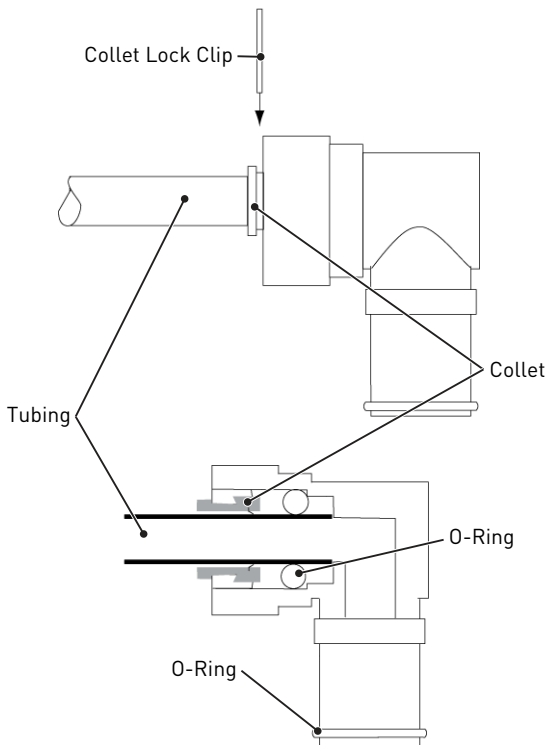

Tip



For optimal system performance, use tubing lengths that are as short as possible. Make sure the tubing is pushed past the O-rings for a secure fit. Also, when replacing any tubing, cut tubing back about 5 mm prior to re-inserting to prevent leaks.

Postfilter

1. Install the postfilter in line with the blue permeate tubing.
2. Make sure flow direction aligns with water path.
3. Secure tubing with collet lock clips.

Drain adapter (Optional)

The drain adapter has a barbed inlet, the 1/2-inch (12 mm) red tube.

1. Put the tubing in position.

Tip

Wet the tubing to slide tubing into the drain adapter inlet.

Water will help the tubing slide into the rubber inlet.

2. Make sure the tubing is pushed past the O-rings for a secure fit.

Tip

When replacing any tubing, cut tubing back about 5 mm prior to re-inserting to prevent leaks.

3. Use the supplied hose clamps to secure the connection.

Feed pressure gauge

The supplied pressure gauge can be connected to the feed line to monitor system feed pressure. For proper system performance, the dynamic feed pressure must be between 2.8 bar and 5.5 bar when the system is in operation.

Info

The feed pressure gauge is intended for use only during installation and troubleshooting of the PRF-R0 system.

The pressure gauge should be removed during normal system operation because some regulatory agencies did not evaluate the PRF-R0 system with the feed pressure gauge in place.

4.3.5 System installation

The PRF-R0 assembly includes the following components: sumps, support leg, prefilter, PRF-R0 membrane elements, and postfilter. The tubing is attached to the manifold by the elbow connectors. When choosing a location for the system, allow enough tubing for it to be moved for periodic servicing of the filters and membrane elements.

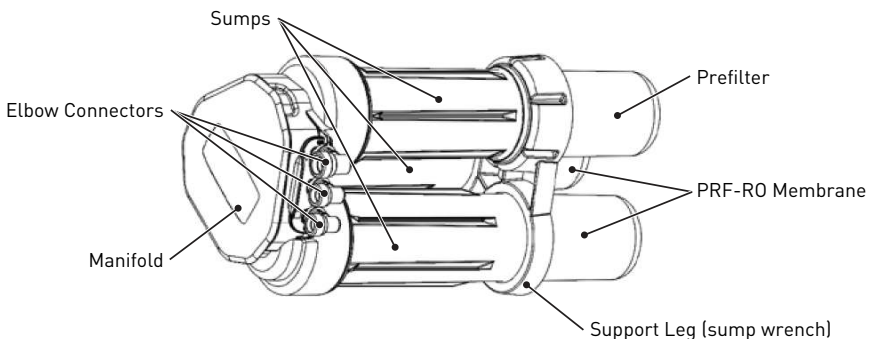
**Tip**

Do not attempt to mount/hang the system. Do not try to drill mounting holes anywhere on the system. If putting above ground/cabinet level, a sturdy, permanent shelf is recommended.

Recommended Placement Positions

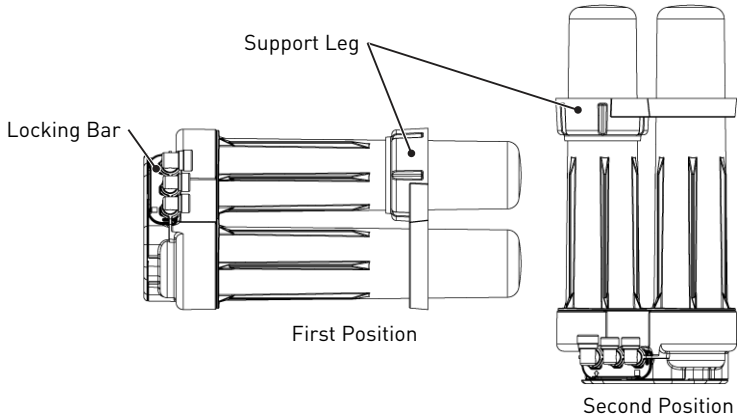

1. Position the PRF-RO assembly in one of the two ways shown above.

Info



The first position uses the support leg with the sumps horizontal. The tubing is directed to provide the best fit.

The second position sets the unit on end so the sumps are pointing up. The tubing is directed upward and the locking bar is down to lock the tubing connections.

2. Ensure that the support leg is installed on the sumps.
3. Insert the fittings into manifold.
4. When all of the connections have been made, fit in place the locking bar to hold the fittings in position.

Mandatory



Match the symbols on the locking bar to the corresponding symbols on the manifold.

The table below shows the coding system for the fitting connections. Each fitting has a unique “keyed” socket on the manifold. Each fitting also has a graphic symbol molded into the elbow with a corresponding symbol on the manifold.

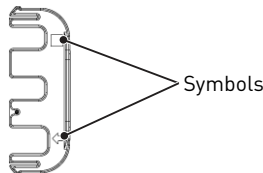

Connector Symbol	Connection	Tubing Color
↶	Feed-Inlet	Natural
—	Concentrate	Black

Connector Symbol	Connection	Tubing Color
□	Product	Blue

4.3.6 System assembly

1. Inspect all connections.
2. Position manifold horizontal with openings facing up.
3. Remove new membrane elements from plastic packaging. The black and yellow tapes surrounding the membrane are an important part of the membrane element and should not be removed.

Mandatory



Connections with O-rings must be properly lubricated !

Follow below instructions describing the method and locations for lubrication.

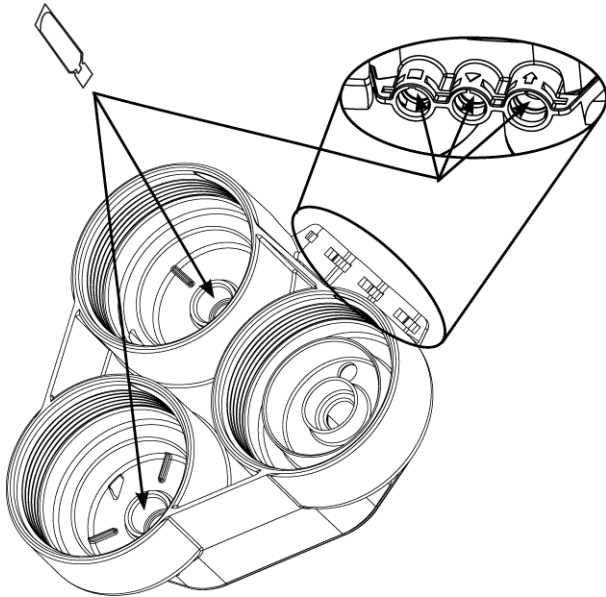

4. Lubricate the O-ring contact surfaces in the 3 manifold ports and 2 PRF-R0 membrane locations using one packet of silicone lube (of the six provided with the PRF-R0).

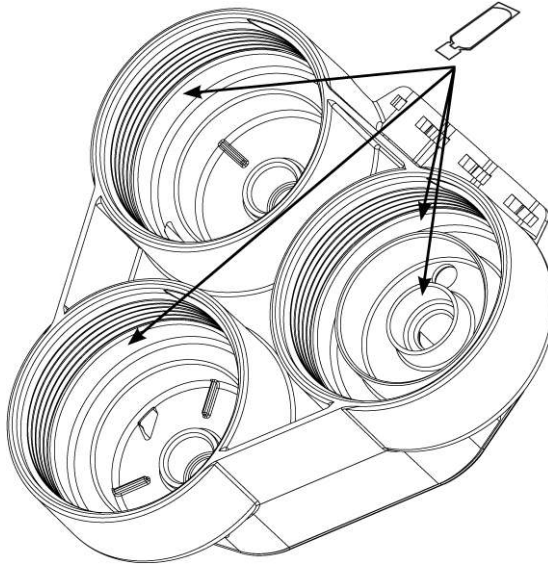

5. Lubricate the filter seat and the flat surface below the threads for the 3 sump locations using one packet of silicone lube (of the six provided with the PRF-RO).

Tip



To properly lubricate the O-ring contact area, apply a film of clean silicone grease.

The film should cover all of the surface area that the O-ring will slide over and seal with.

Prohibition



Do not use grease containing petroleum products !

6. Securely insert O-ring end of membrane elements into manifold.
7. Remove prefilter from packaging.
8. Check that gaskets are in place.
9. Place prefilter in manifold.
10. Replace sumps and tighten until it bottoms out.

4.4 Sink

For multi compartment sinks or single compartment sink without disposal.

4.4.1 List of part enclosed

- 1 Drain Line Adapter with Barb Connection (ET109-003/
ET112-003)



- 2 3 Way Repair Tee
- 3 Slip Joint (S.J.) Wing Nuts
- 4 Slip Joint (S.J.) Beveled Washers



Info

i The ET112-003 provides an IAPMO / UPC listed alternative to the use of the drain saddle which is a prohibited fitting in the United States

Mandatory

! To install the ET112-003 reverse osmosis reject water Drain Line Adapter, follow these instructions.

4.4.2 Vertical Installation

Mandatory

! Please read the instructions once through before starting.

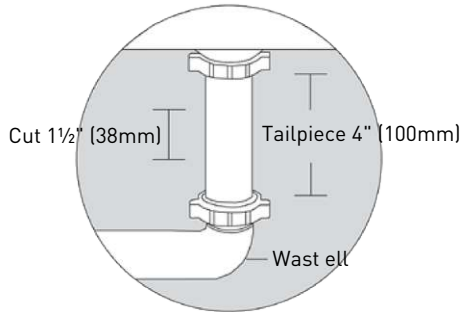

1. Measure the midpoint on the vertical tailpiece between the basket strainer and the horizontal waste ell. A minimum of 4" (100 mm) of "exposed" tubing is required.
2. Cut out 1½ (38 mm) of tubing (¾ (19 mm) on both sides of midpoint measurement). Always ensure that tube ends are cut squarely and inserted into the bottom of all slip joint (SJ) sockets.

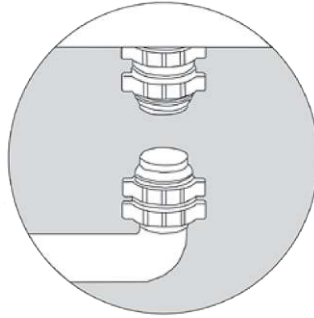

3. Slip SJ nut and beveled washer over both ends of cut tube. Always face the beveled side of washer towards fitting.

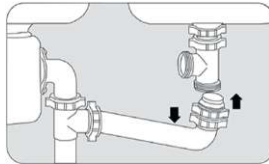

4. Insert the 3-way repair tee (provided), ensuring that tube ends seat completely into sockets of tee. This may be accomplished by loosening the SJ nut joining the horizontal waste ell to the baffle tee until there is enough play to bend the waste ell down, then up into the bottom of the 3-way repair tee.
5. Rotate side outlet of repair tee to desired direction and firmly tighten top, then bottom SJ nuts. Now re-secure the waste ell to the baffle tee.

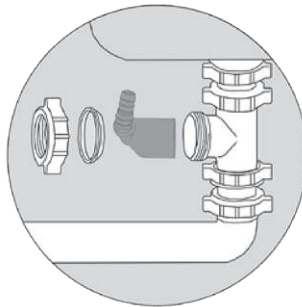

6. Insert new drain line adapter with barb into side outlet of tee, and rotate towards incoming 1/2" (12 mm) rejected water drain tube. Make sure that adapter is firmly seated in bottom of socket, the tightly secure with beveled SJ washer and wing nut (provided).

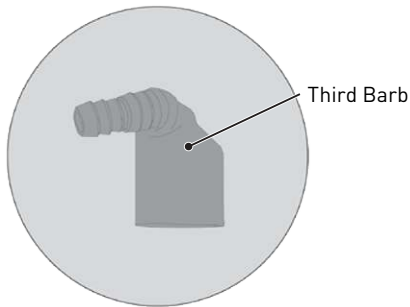

7. Insert ½" (12 mm) drain tube over barb connector to complete the installation.

Mandatory



To assure a leak free connection, tubing must seat fully up to third barb !

8. Check that connection is leak free.

ET112-003 to a single compartment sink without disposal installation

1. Follow the 6 previous steps with the following exception: once you have removed 1½" (38 mm) of the tubing from the center of the tailpiece.
2. Disconnect and lower the J-bend of the trap.

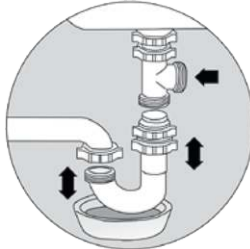

Tip



Use a bowl to catch trap water.

3. Insert the 3-way repair tee.
4. Reconnect the trap.

4.4.3 Horizontal Installation

Even the horizontal installation is possible, for best results Pentair recommends to use Vertical Installation [→Page 24] only.

Mandatory



Please read the instructions once through before starting.

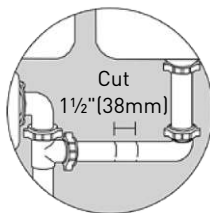

1. Measure the midpoint on the horizontal waste ell and cut out 1 1/2" (38 mm) of tubing.

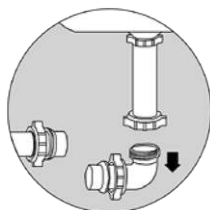

2. Slip joint (SJ) nut and beveled washer over both ends of cut tube.
3. Insert the 3-way repair tee in the following manner: loosen the SJ nut on the horizontal waste ell where it joins the vertical tailpiece.
4. Remove the short "ell" piece by pulling down the tailpiece.
5. Put cut ends of ell into tee and tilt vertical end back up over tailpiece and re-secure SJ nut.

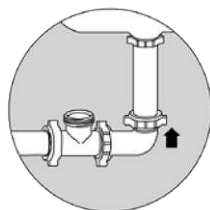

6. Rotate tee so that the side outlet is facing straight up, then firmly tighten both SJ nuts to tee.
7. **Optional:** to further decrease or eliminate reject water noise, rotate side outlet for tee from vertical down to 45 degrees.
8. Follow the last two steps of Vertical Installation [→Page 24] to complete installation.

4.4.4 Not recommended procedure

Mandatory



Please read the instructions once through before starting.

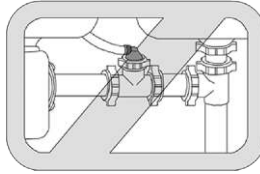

1. For best results: do not install an ET112-003 on the horizontal pipe coming straight out of the disposal. If the vertical tailpiece is too short, use ET116-003 or ET116-004.

Caution - material**Risk of damage due to over-tightening !**

Do not to "over-tighten" any screw on plastic fitting.

Info

To connect a reverse osmosis reject water drain line to the plumbing of a single compartment sink with disposal, please request an ET109-003 or ET116-003.

The ET112-003 is designed to be used downstream of an approved airgap.

5 Water filling, draining and waterproofness inspection

Info



To check for leaks, the system must be filled with water and brought up to operating pressure.

1. Open cold water feed valve slowly.
2. Run at 1/2 open for a minute, then open fully.
3. Open faucet until water runs.
4. Check for leaks.

Info



When the faucet is initially turned on, water may temporarily sputter from the air gap until the air is purged.

Allow 1 to 3 hours for any trapped air noise in the system to subside.

5. Purge the system opening the faucet and run the water through the PRF-RO system for two to eight hours.

Info



After 8 hours performance will reach its stable maximum performance.

The PRF-RO system is now ready for use.

6 Maintenance

6.1 Maintenance plan

The components of the PRF-RO system are designed to function with minimal maintenance. However, the membrane elements and filters will need to be replaced on a regular schedule.

For optimal performance the system should be flushed for 2 minutes if periods of inactivity extend past six hours.

6.1.1 Replacement of prefilter and postfilter

The carbon/sediment prefilter reduces sediment and certain chemicals, such as chlorine, from the water. Depending on water use and the amount of impurities, this filter should be replaced every six to twelve months for point-of-use applications.

Whenever the prefilter is replaced, the postfilter should also be replaced.

Installations using more than 75 liters product water per day should install external filters (not supplied) to reduce chlorine and sediment larger than 10 microns.

6.1.2 Replacement of PRF-RO membrane

The functional life of the PRF-RO membrane elements will vary based on feed water quality. Product water should be tested periodically to verify the membrane elements are performing properly. For most point-of-use applications, the PRF-RO membrane elements should be replaced every two to four years.

Info



Softened water is recommended for optimal system performance and PRF-RO membrane element life.

6.2 Parts replacement

6.2.1 Operations to do before changing elements

1. Turn off the water supply to the PRF-RO system.
2. Reduce system water pressure by opening the faucet.
3. Position the PRF-RO assembly in a sink or tub.
 - ⇒ Most of the water will be contained. Even with the water supply turned off the membrane and prefilter sumps will contain a considerable amount of water.
4. Disconnect locking bar, pull fittings out and place the fittings with tubing still connected into a tub or bucket.

Info



There is no need to disconnect tubing from fittings on the manifold.

6.2.2 Membrane elements replacement

Mandatory



If changing the membrane elements, the prefilter and postfilter should also be changed.

Refer to Prefilter replacement [→Page 32].

1. Remove membrane sumps.
2. Remove and discard used elements.
3. Remove new elements from packaging.
4. Lubricate element O-rings, brine seals, and sump O-rings with silicone lubricant. Refer to System assembly [→Page 22] for correct lubrication procedure of elements cartridge.

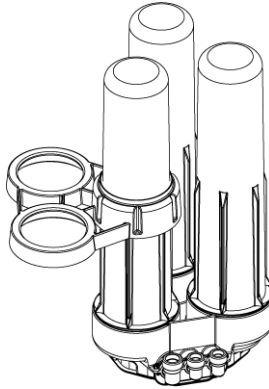

5. Securely insert O-ring end of elements into manifold.
6. Replace sumps.
7. Tighten until it bottoms out.
8. Re-connect the system.

⇒ Refer to System re-connecting [→Page 32].

Mandatory



The system should be sanitized whenever a membrane element or filter is replaced !

Refer to Sanitization [→Page 33].

6.2.3 Prefilter replacement

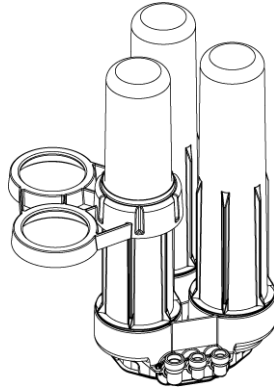

1. Remove the support leg from the three sumps and unscrew the top sump as shown to access the prefilter element.

Tip



The support leg functions as a wrench to loosen the sump.

Info



If changing only the prefilter, the other sumps do not need to be removed.

2. Remove exhausted prefilter and discard.
3. Lubricate O-rings with silicone prior to re-assembly.
4. Re-connect the system.
 - ⇒ Refer to System re-connecting [→Page 32].

6.2.4 Postfilter replacement

1. Unlock the fittings from the tubing by pushing down on the collet sleeves and pulling the tubing out.
2. Discard the exhausted postfilter.
3. To prevent leaks, cut the tubing back approximately 1/4-inch prior to connecting the new postfilter.
4. Make sure flow direction arrow aligns with water path.
5. Reinsert tubing and collect locks.

6.2.5 System re-connecting

1. Re-connect the fittings to the manifold and lock in position with locking bar.
2. Re-position the assembly and turn the water supply on.
3. Check the system for any leaks.

Info



When the faucet is opened, water may sputter from the air gap until the trapped air is purged.

4. Open the faucet and run water for two minutes.

Info



Carbon fines may be present until the postfilter element is flushed out.

5. Shut off the faucet and allow the system to stand idle for 20 to 30 minutes.
6. Open the faucet and run water for five minutes.
7. Check for any system leaks.

Info



If the two PRF-RO membrane elements were replaced the system must be flushed according to System assembly [→Page 22] as stated above.

The PRF-RO system is now ready for use.

6.2.6 Sanitization

1. The manifold should be positioned flat with the sump connections facing up.

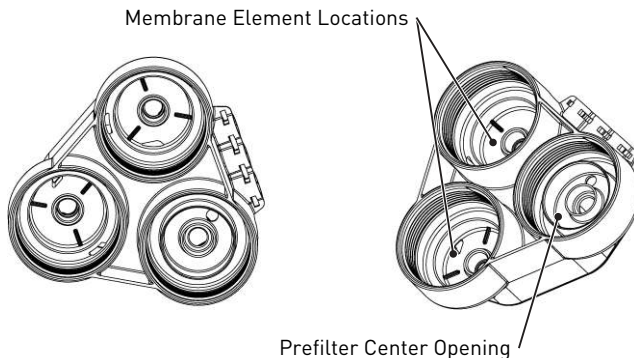

2. Pour a tablespoon (15 milliliters) of chlorine bleach into the center opening of the prefilter sump connection.
3. Chlorine bleach can be commercial bleach with a 5% concentration.
4. Once the bleach is inside the manifold holes, wait a few minutes and put back on the sumps.
5. Turn the system upwards (manifold was upside down so far) and slowly fill the device with water until it is completely filled.
6. Let it standing for +/- 30 minutes
7. Rinse and re-mount prefilter and membranes (new ones) with clean hands.

7 TroubleShooting

Issue	Possible Cause	Corrective Action
Low product flow rate	Low driving pressure.	Increase feed pressure. Consider pump for low pressure locations. Use short tubing runs to decrease flow restriction. Increase tubing diameter for longer distances.
	Low water temperature or high total dissolved solids (TDS).	Increase feed water temperature or feed pressure to compensate.
	Plugged prefilter.	Replace plugged prefilter. Consider sediment prefilter for nonchlorinated applications.
	Scaled or fouled PRF-RO membrane.	Replace membranes.
	Faucets not adjusted properly.	Adjust faucet t-bar setting as tight as possible without causing leaks from the faucet.
	Plugged postfilter.	If flow into the postfilter is not acceptable, replace postfilter.
	Leak or kink in product line.	Find and repair leak or kink.
Concentrate water runs to drain after faucet shut off	Plugged prefilter.	Replace plugged prefilter. Consider sediment prefilter for nonchlorinated applications.
	Leak in product line.	Find and repair leak. Install pressure gauge in product line to help identify a product pressure leak.
Poor product water quality	Water sample taken during system flush.	Take sample after three minutes of continuous operation.
	Low driving pressure.	Increase feed pressure. Consider pump for low pressure locations. Use short tubing runs to decrease flow restriction. Increase tubing diameter for longer distances.
	Plugged prefilter.	Replace plugged prefilter. Consider sediment prefilter for nonchlorinated applications.
	Scaled, fouled, or damaged PRF-RO membrane.	Replace PRF-RO membranes.

8 Disposal

The device must be scrapped in accordance with directive 2012/19/EU or the environmental standards in force in the country of installation. The components included in the system must be separated and recycled in a waste recycling center that conforms with the legislation in force in the country of installation. This will help to reduce the impact on the environment, health, safety and help to promote recycling. Pentair does not collect used product for recycling. Contact your local recycling center for more information.



www.pentair.eu