

Riversoft 368 (604-606)



IMPORTANT SAFETY INSTRUCTIONS

Read and follow all instructions

Save these instructions

WWW.PENTAIR.EU

Table of Contents

1	Generalities	5
1.1	Scope of the documentation	5
1.2	Release management	5
1.3	Manufacturer identifier, product identification	5
1.4	Intended use	5
1.5	Abbreviations used	6
1.6	Norms	6
1.6.1	Applicable norms	6
1.6.2	Available certificates	6
1.7	Procedure for technical support	6
1.8	Copyright and Trademarks	7
1.9	Limitation of liability	7
1.10	Illustrations	7
2	Safety.....	8
2.1	Safety pictograms definition	8
2.2	Serial label location	9
2.3	Hazards	9
2.3.1	Personnel	9
2.3.2	Transport.....	10
2.3.3	Material	10
2.4	Hygiene and sanitization	10
2.4.1	Sanitary issues	10
2.4.2	Hygiene measures	12
3	Description	13
3.1	Introduction to softeners	13
3.1.1	Softening principles	13
3.1.2	System service & regeneration cycles (8-cycles operation)	15
3.2	Technical specifications.....	17
3.2.1	General.....	17
3.2.2	Performance flow rate characteristics	18
3.3	Outline drawing	20
3.4	Description and component location	22
3.5	Softener's available options	24
3.5.1	Safety brine valve	24
3.6	Accessories included	24
4	Installation	25
4.1	Warnings	25

4.2	Safety notices for installation	25
4.3	Installation environnement.....	25
4.3.1	General.....	25
4.3.2	Water	25
4.3.3	Electrical	26
4.3.4	Mechanical	26
4.4	Integration constraints	27
4.5	Softener connection to piping.....	28
4.5.1	Block diagram	28
4.5.2	Installation layout.....	29
4.5.3	Tools and material required for installation	30
4.5.4	Inspection/preliminary assembly	30
4.5.5	Softener installation.....	31
4.5.6	Water supply line and bypass connections.....	32
4.5.7	Drain line flow controller	37
4.5.8	Drain line connection	38
4.5.9	Overflow line connection.....	39
4.6	Electrical connection	40
4.6.1	Meter connection	40
4.6.2	Controller connection	41
5	Programming	42
5.1	Display.....	42
5.2	Commands	42
5.3	Quick program guide	43
5.4	Time of day	43
5.5	Brine dosage	44
5.6	Volumetric regeneration.....	44
5.7	Time clock regeneration (Riversoft 4 only)	44
5.8	Calendar override setting	44
5.9	System selection	45
5.10	Regeneration cycles time	45
5.11	History values.....	46
5.12	Resetting the controller and system selection (u1 to u4)	46
6	Commissioning	48
6.1	Softener commissioning.....	48
6.1.1	Water filling, draining and waterproofness inspection	48
6.1.2	Quick cycling	49
6.1.3	Startup.....	50
6.1.4	Additional tips.....	50
6.2	Cleaning, disinfection and sanitization.....	51
6.2.1	Cleaning of softeners.....	51

6.2.2	Disinfection with sodium or calcium hypochlorite	51
7	Operation	52
7.1	Display	52
7.1.1	During operation	52
7.1.2	During regeneration.....	52
7.2	Manual regeneration	52
7.2.1	Manual delayed regeneration	52
7.2.2	Immediate regeneration	52
7.2.3	To advance regeneration cycles	53
7.2.4	To cancel a regeneration	53
7.3	Operation during a power failure	53
8	Maintenance	54
8.1	General system inspection	54
8.1.1	Water quality	54
8.1.2	Mechanical checks.....	54
8.1.3	Regeneration test.....	55
8.2	Recommended maintenance plan.....	55
8.2.1	Maintenance instructions	56
8.3	Adding salt	57
8.4	Recommendations	59
8.4.1	Use original spare parts	59
8.4.2	Use original approved lubricants.....	59
8.5	Cleaning and maintenance	59
8.5.1	First steps	59
8.5.2	Covers removal (softener and valve).....	60
8.5.3	Brine tank and brine well cleaning.....	61
8.5.4	Cleaning the injector screen.....	62
8.5.5	Cleaning the injector.....	63
8.5.6	Controller replacement	64
8.5.7	Other wear and tear parts.....	65
9	Troubleshooting	73
9.1	Controller	73
9.2	Valve	74
9.3	System.....	75
10	Spare parts.....	76
10.1	Softener.....	76
10.2	Valve	78
10.3	Piping.....	80
11	Disposal.....	82

1 Generalities

1.1 Scope of the documentation

The documentation provides the necessary information for appropriate use of the product. It informs the user to ensure efficient execution of the installation, operation or maintenance procedures.

The content of this document is based on the information available at the time of publication. The original version of the document was written in English.

For safety and environmental protection reasons, the safety instructions given in this documentation must be strictly followed.

The manufacturer reserves the right to make changes at any time without notice.

This manual is a reference and will not include every system installation situation. The person installing this equipment should have:

- training in the 368 valves, (604-606) controllers and water treatment appliances installation;
- knowledge of water conditioning and how to determine proper controller settings;
- basic plumbing skills.

This document is available in other languages on <https://www.pentair.eu/product-finder/product-type/softeners>.

1.2 Release management

Revision	Date	Authors	Description
A	13.03.2020	STF/GPI	First edition.
B	16.01.2023	BRY/FIM	Website, new design and scan & service removal.
C	03.03.2026	STF	General corrections, Update of the manufacturer's address.

1.3 Manufacturer identifier, product identification

Manufacturer: **EMEA legal entity**
 Pentair Manufacturing Italy S.R.L.
 Via Tiziano 32
 20145 Milano (MI)
 Italy

Product identification: Riversoft

1.4 Intended use

- For domestic use only;
- the water softener series Riversoft may only and exclusively be used for residential water softening under specified conditions, see Water [→Page 25];
- the water softener series Riversoft protects water pipes and connected water-carrying systems from scaling, respectively from malfunctions and damage caused by scaling;

- the water softener series Riversoft is designed for continuous supply of water for different family sizes depending on the chosen model.

1.5 Abbreviations used

Assy	Assembly
BLFC	Brine Line Flow Controller
DF	Down Flow
DLFC	Drain Line Flow Controller
Inj	Injector
QC	Quick Connect
Regen	Regeneration
SBV	Safety Brine Valve
TC	Time Clock

1.6 Norms

1.6.1 Applicable norms

Comply with the following guidelines:

- 2014/35/UE: Low Voltage Directive;
- 2014/30/UE: Electromagnetic compatibility;
- 2011/65/UE: Restriction of use of certain hazardous substances in electrical and electronic equipment (RoHS);
- UNI EN ISO9001.

Meets the following technical standards:

- EN IEC 61326-1;
- EN IEC 61010-1.

1.6.2 Available certificates

- CE;
 - DM174;
 - ACS.
- Please find beside the certifications for some of our product families. Please note that this list is not an exhaustive list of all our certifications. In case of need for more information please contact us.



1.7 Procedure for technical support

Procedure to follow for any technical support request:

1. Collect the required information for a technical assistance request.
 - ⇒ Product identification (see Serial label location [→Page 9] and Recommendations [→Page 59]).
 - ⇒ Description of the device problem.

2. Please refer to the Troubleshooting [→Page 73]. If the problem persists contact your local tech support.

1.8 Copyright and Trademarks

All indicated Pentair trademarks and logos are property of Pentair. Third party registered and unregistered trademarks and logos are the property of their respective owners.

© 2026 Pentair. All rights reserved.

1.9 Limitation of liability

Pentair Water Treatment EMEA products benefit, under specific conditions, from a manufacturer warranty that may be invoked by Pentair's direct customers. Users should contact the vendor of this product for applicable conditions and in case of a potential warranty claim.

Any warranty provided by Pentair regarding the product will become invalid in case of:

- installation done by a non-water-professional;
- improper installation, improper programming, improper use, improper operation and/or maintenance leading to any kind of product damages;
- improper or unauthorized intervention on the controller or components;
- incorrect, improper or wrong connection/assembly of systems or products with this product and vice versa;
- use of a non-compatible lubricant, grease or chemicals of any type and not listed by the manufacturer as compatible for the product;
- failure due to wrong configuration and/or sizing.

Pentair accepts no liability for equipment installed by the user upstream or downstream of Pentair products, as well as for process/production processes which are installed and connected around or even related to the installation. Disturbances, failures, direct or indirect damages that are caused by such equipment or processes are also excluded from the warranty. Pentair shall not accept any liability for any loss or damage to profits, revenues, use, production, or contracts, or for any indirect, special or consequential loss or damage whatsoever. Please refer to the Pentair List Price for more information about terms and conditions applicable to this product.

1.10 Illustrations

Depending on the configuration of your softener, it can be mounted with a bypass or a manifold. We chose to use the bypass configuration to illustrate this document. However when necessary, we illustrated both configurations.

2 Safety

2.1 Safety pictograms definition

DANGER



This combination of symbol and keyword indicates an imminently hazardous situation that will result in serious or fatal injury if not avoided.

WARNING



This combination of symbol and keyword indicates a potentially hazardous situation that can result in serious or fatal injury if not avoided.

CAUTION



This combination of symbol and keyword indicates a potentially hazardous situation that can result in minimal or minor injury if not avoided.

Caution - material



This combination of symbol and keyword indicates a potentially hazardous situation that can result in material damage if not avoided.

Prohibition



Mandatory advice to follow.

Mandatory



Applicable guideline, measure!

Info



Informative comment

2.2 Serial label location

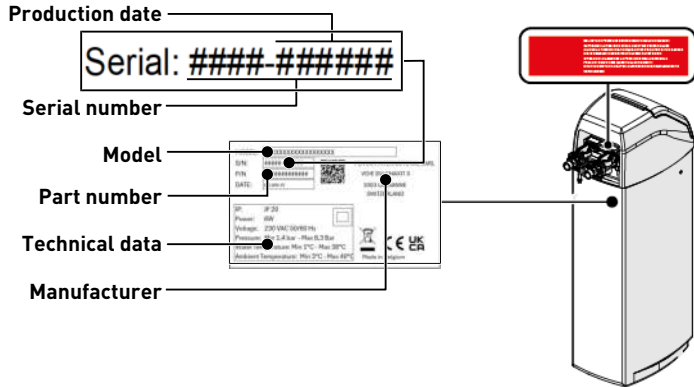

Mandatory



Ensure that the serial label and the safety labels on the device are completely legible and clean!

2.3 Hazards

All the safety and protection instructions contained in this document must be observed in order to avoid temporary or permanent injury, damage to property or environmental pollution.

At the same time, any other legal regulations, accident prevention and environmental protection measures, as well as any recognized technical regulations relating to appropriate and risk-free methods of working which apply in the country and place of use of the device must be adhered to.

Any non-observation of the safety and protection rules, as well as any existing legal and technical regulations, will result in a risk of temporary or permanent injury, damage to property or environmental pollution.

2.3.1 Personnel

CAUTION



Risk of injury due to improper handling!

Only qualified and professional personnel, based on their training, experience and instruction as well as their knowledge of the regulations, the safety rules and operations performed, are authorized to carry out necessary work.

WARNING



Appliance

This appliance can be used by children aged from 8 years and above and persons with reduced physical, sensor or mental capabilities or lack of experience and knowledge if they have been given supervision or instruction concerning use of the appliance in a safe way and understand the hazards involved.

WARNING
**Children**

Children shall not play with the appliance.

Cleaning and salt refill shall not be made by children without supervision.

Mandatory

Any other maintenance operation must be carried out only by qualified and professional personnel!

2.3.2 Transport

The following points must be observed to ensure proper operation of the system:

- do not lay down or flip over the softener at any time. The media may paste to the upper distributor thus obstructing its slots or enter the valve and may therefore compromise the softener operation;
- pay attention not to hit the softener;
- use all the safety lifting systems to move the softener;
- do not lift the softener by the valve or bypass.

2.3.3 Material

The following points must be observed to ensure proper operation of the system and the safety of user:

- beware of high voltages present on the transformer (220 – 230 VAC);
- do not put your fingers in the system (risk of injuries with moving parts and shock due to electric voltage).

2.4 Hygiene and sanitization**2.4.1 Sanitary issues****Preliminary checks and storage**

- Check the integrity of the packaging. Check that there is no damage and no signs of contact with liquid to make sure that no external contamination occurred;
- check that the brine tank and the brine well are clean and free from burr, debris or any scraps;
- the packaging has a protective function and must be removed just before installation. For transportation and storage, appropriate measures should be adopted to prevent the contamination of materials or the objects themselves.

Assembly

- Assemble only with components which are in accordance with drinking water standards;
- after installation and before use, perform one or more manual regenerations in order to clean the media bed. During such operations, do not use the water for human consumption. Perform a disinfection of the system in the case of installations for treatment of drinking water for human use.

Info



This operation must be repeated in the case of ordinary and extraordinary maintenance.

It should also be repeated whenever the system remains idle for a significant time.

Info



Valid only for Italy

In case of equipment used in accordance with the DM25, apply all the signs and obligations arising from the DM25.

2.4.2 Hygiene measures

DANGER



Do not use with water that is micro-biologically unsafe or of unknown quality without adequate disinfection before or after the softener.

WARNING



Water softeners using sodium chloride for regeneration will add sodium to the water.

Person who are on sodium-restricted diets should consider the added sodium as part of their overall sodium intake.

Disinfection

- The materials used for the construction of our products meet the standards for use with potable water; the manufacturing processes are also geared to preserving these criteria. However, the process of production, distribution, assembly and installation, may create conditions of bacterial proliferation, which may lead to odor problems and water contamination;
- it is therefore strongly recommended to sanitize the products. See Cleaning, disinfection and sanitization [[→Page 51](#)];
- maximum cleanliness is recommended during the assembly and installation;
- for disinfection, use Sodium or Calcium Hypochlorite and perform a manual regeneration.

3 Description

3.1 Introduction to softeners

3.1.1 Softening principles

Softening is an ion exchange process where the hard ions are getting exchange by soft ions, typically sodium or potassium. This is achieved by placing the water in contact with an ion exchange resin and ensuring the contact time is appropriate for the flow rate to produce.

The basic chemistry of softening resins is very simple: the resin is made of small polymer beads with chemical functionality that selectively captures the divalent ions (such as Ca^{2+} and Mg^{2+} - hardness ions) and releases in exchange less tightly held monovalent ions, usually sodium (Na^+) or less frequently potassium. Here below is shown the chemical reactions mechanism for softening:

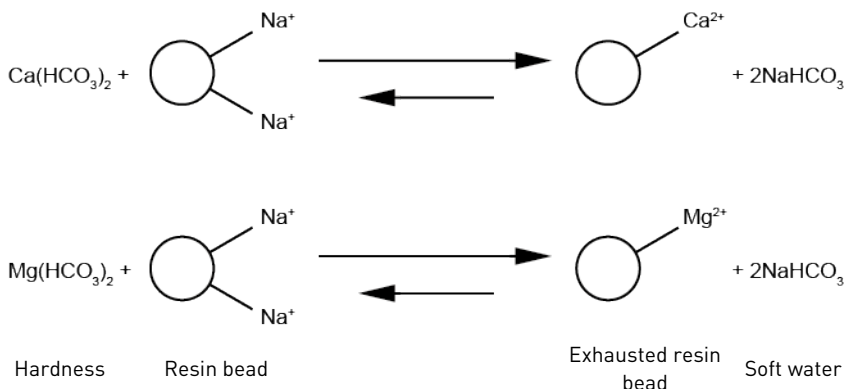

The \rightleftharpoons means that under certain conditions, the reactions can be reversed. This is due to the equilibrium between the water composition and the amount of hardness that can be removed. This reverse reaction is observed at different kinetics and at high monovalent ions concentration. Usually for softening this conditions are obtained using concentrated NaCl (or KCl) solutions that are put in contact with the resin. This is called regeneration:

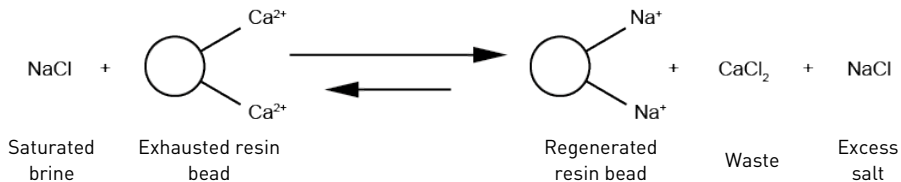

The service and regeneration reaction can be done over and over, so softening systems last years.

A softener consists of different components:

- a tank, filled with softening resin;
- a valve, that will direct the inlet water flow on the resin bed so that the softening or regeneration reaction can take place;
- a timer, that will control when the regeneration phases have to be done;

- a brine tank, where saturated brine solution is prepared for the regenerations.

The present softener will simply allow the previously described reaction to happen, alternating softening period of few days with regeneration that may last up to few hours depending on setting done. The softener is equipped with a controller that will trigger automatically the different phases of service and regeneration upon the programming done.

The valve configuration has been chosen to be in accordance with the volume of resin contained in the tank. Do not intend to modify it or you may cause kinetics changes and may cause regeneration malfunction.

In order to ensure proper softener function, make sure it always contains salt in the brine tank and remains electrically powered. Softener installation, start up and programming must be done by trained professional water treatment specialist. Incorrect installation or wrong programming may cause softener malfunctions or even damage the softener and its components.

Respect programming recommendations for each softener size in order to achieve best optimized softener performances.

Softener requires periodical cleaning/maintenance operations to ensure proper function over years. Those are described in the present manual on chapter Maintenance [[->Page 54](#)].

3.1.2 System service & regeneration cycles (8-cycles operation)

Service (downflow) — cycle C0

Untreated water is directed down through the resin bed and up through the riser tube. The hardness ions attach themselves to the resin and are removed from the raw water being exchanged on the resin beads against sodium ions. The water is conditioned as it passes through the resin bed.

Backwash (upflow) — cycle C1

The flow of water is reversed by the valve and directed down the riser tube and up through the resin bed. During the backwash cycle, the bed is expanded and debris are flushed to the drain, while the media bed is remixed.

Brine draw (downflow) & slow rinse — cycle C2

The valve directs water through the brine injector and brine is drawn from the brine tank. The brine is then directed down through the resin bed and up through the riser tube to the drain. The hardness ions on the resin beads are replaced by sodium ions and are sent to the drain. The resin is regenerated during the brine cycle. When the air check valve closes brine draw finishes, and then the slow rinse phase starts.

Repressurization cycle — cycle C3

This cycle allows the air and water to hydraulically balance in the valve before continuing the regeneration.

Rapid rinse (downflow) — cycle C4

The valve directs water down through the resin bed and up through the riser tube to the drain. Any residual brine is rinsed from the resin bed, while the media bed is recompact.

2nd Backwash (upflow) — cycle C5

2nd Rapid rinse (downflow) — cycle C6

Brine refill — cycle C7

Water is directed to the brine tank at a rate controlled by the refill flow controller, to prepare brine for the next regeneration. During brine refill cycle, treated water is already available at the valve outlet.

Info



For illustration purpose only. Always verify inlet and outlet marking on the softener.

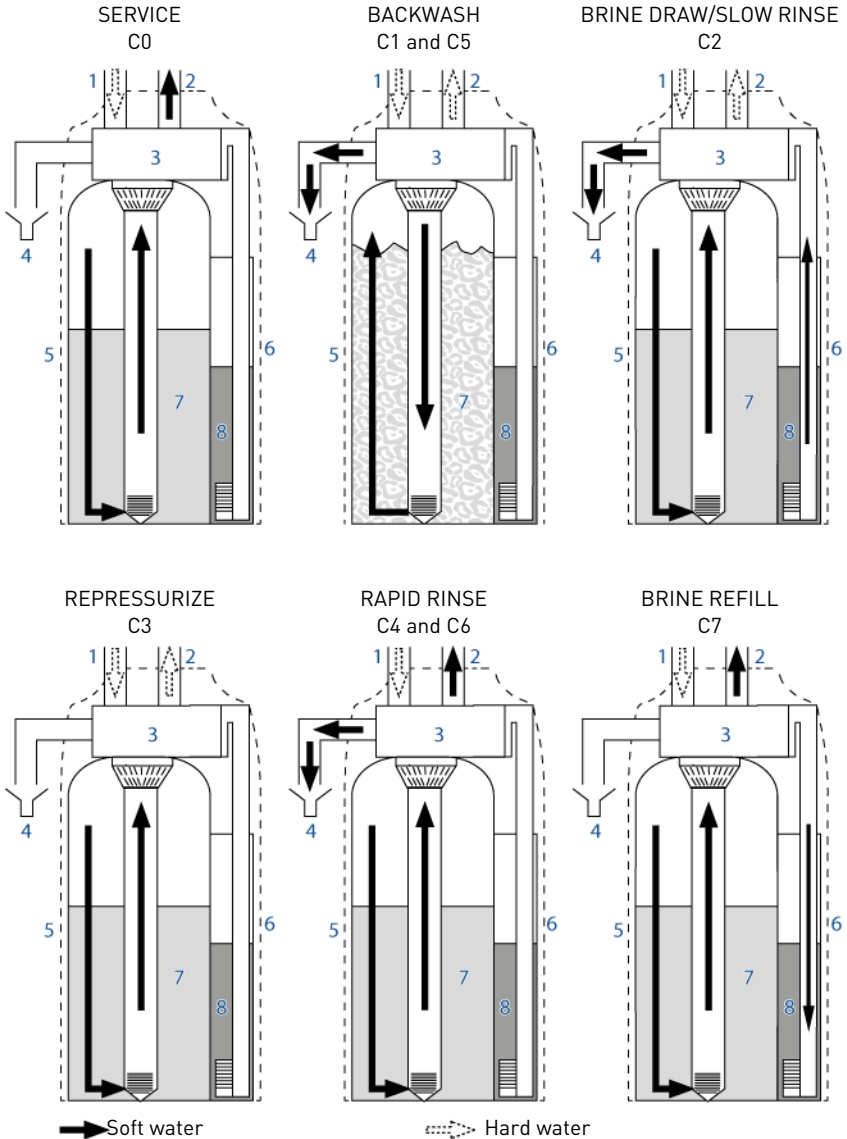

1 Inlet
2 Outlet
3 Valve

4 Drain
5 Media tank
6 Brine tank

7 Media bead
8 Brine

3.2 Technical specifications

3.2.1 General

Riversoft with bypass configuration

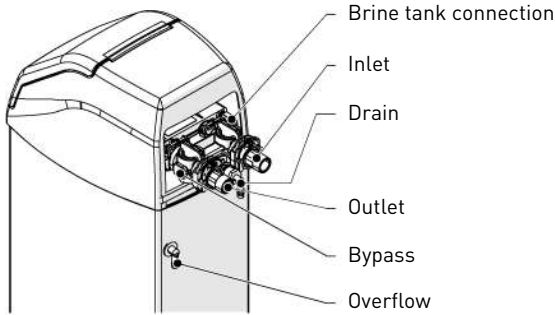

Riversoft with manifold configuration

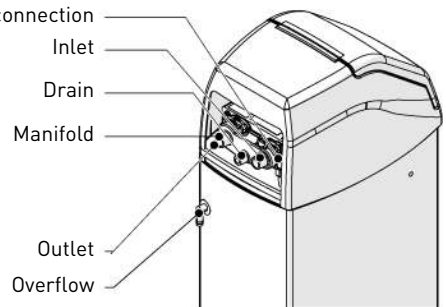

Softener type

Riversoft 4	4 L
Riversoft 8	8 L
Riversoft 15	15 L
Riversoft 30	30 L

Design specifications/ratings

Softener cabinet	ABS			
Tank body	Dowex® HCRS-s resin			
Valve body	Glass-filled Noryl® - NSF listed material			
Rubber components	Compounded for cold water - NSF listed material			
Valve material certification	WQA Gold Seal Certified to ORD 0902, NSF/ANSI 44, CE, ACS			
Volume of resin	4 L	8 L	15 L	30 L
Approximative shipping weight	9.5 kg	16.5 kg	27 kg	30 kg
Salt storage	6 kg	25 kg	50 kg	50 kg

Operating pressure	1.4 – 8.6 bar
Hydrostatic test pressure	20 bar
Water temperature	4 - 38°C
Ambient temperature	2 - 50°C

3.2.2 Performance flow rate characteristics

Info



Flow rates are indicative data. Maximum flow rate to produce in order to respect the required service velocity for an optimal ion exchange upon resin manufacturers recommendation, regardless of the inlet pressure.

Softener	Riversoft			
	4	8	15	30
Nominal (residual hardness 0 mg/l as CaCO ₃) [m ³ /h]	0.2	0.5	0.9	1.8
Nominal (residual hardness 50 - 100 mg/l as CaCO ₃) [m ³ /h]	0.3	0.6	1.1	2.2
Peak (residual hardness mg/l as CaCO ₃) [m ³ /h]	0.4	0.8	1.5	3.0

Softening

Number of people	POU*	1-2	3-4	5-8
------------------	------	-----	-----	-----

* assuming a 200 l per day water consumption at POU (Point Of Use).

Capacity & salt consumption for the different salt dosage setting

Softener	Riversoft 4			Riversoft 8		
	80	120	200	80	120	200
Corresponding salt dosage (g/l of resin)	80	120	200	80	120	200
Salt amount per regen (kg)	0.3	0.5	0.8	0.6	0.9	1.6
Capacity (kg as CaCO ₃)	0.16	0.2	0.24	0.32	0.4	0.5
Capacity in m ³ (for 300ppm inlet hardness and 100ppm residual hardness)	0.79	0.98	1.22	1.60	1.98	2.48
Estimated salt consumption per year (kg) for 200 l daily water consumption per person and 300 mg/l as CaCO ₃ inlet hardness, residual 100 mg/l as CaCO ₃	28.8	34.9	46.6	14.2 - 28.4	17.2 - 34.5	23 - 46

Softener	Riversoft 15			Riversoft 30		
	80	120	200	80	120	200
Corresponding salt dosage (g/l of resin)	80	120	200	80	120	200
Salt amount per regen (kg)	1.2	1.8	3.0	2.4	3.6	6
Capacity (kg as CaCO ₃)	0.6	0.75	0.93	1.21	1.49	1.86
Capacity in m ³ (for 300ppm inlet hardness and 100ppm residual hardness)	3.02	3.74	4.67	6.03	7.45	9.31

Softener	Riversoft 15			Riversoft 30		
Estimated salt consumption per year (kg) for 200 l daily water consumption per person and 300 mg/l as CaCO ₃ inlet hardness, residual 100 mg/L as CaCO ₃	45.8 - 61	55.5 - 74	74.1 - 98.8	86.6 - 115.5	105.1 -	145.9 - 233.5

Valve configuration

Injector	E	G	F	H
DLFC	6 gpm	8 gpm	7 gpm	9 gpm
BLFC	0.14 gpm	0.14 gpm	0.14 gpm	0.14 gpm

	Riversoft 4			Riversoft 8			Riversoft 15			Riversoft 30		
C1	1	1	1	1	1	1	3	3	3	3	3	3
C2	27	28	30	29	31	34	52	56	63	59	66	81
C3	3	3	3	3	3	3	3	3	3	3	3	3
C4	1	1	1	1	1	1	3	3	3	3	3	3
C5	1	1	1	1	1	1	1	1	1	1	1	1
C6	1	1	1	1	1	1	1	1	1	1	1	1
C7	1.7	2.5	4.1	3.4	5	8.3	54.8	58.5	65.6	12.5	18.8	31.2

Riversoft 4			Riversoft 8			Riversoft 15			Riversoft 30		
24.6	25.5	27.4	36.1	38.0	41.3	54.8	58.5	65.6	104.5	113.1	131.0

Softener connections

Inlet/Outlet	¾" BSPT, male
Drain line	½"
Overflow drain line	½"

Electrical

Controller Operating Voltage	12 VAC (requires use of Pentair Water supplied transformer)
Input supply frequency	50 or 60 Hz
Motor input voltage	12 VAC
Controller Power Consumption	6 W average
Protection rating	IP 23
Transient overvoltages	within the limits of category II
Pollution Degree	3

Temporary overvoltages must be limited in duration and in frequency.

3.3 Outline drawing

Riversoft 4

Bypass configuration

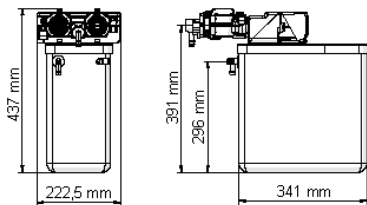

Manifold configuration

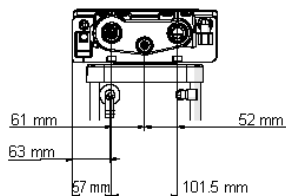
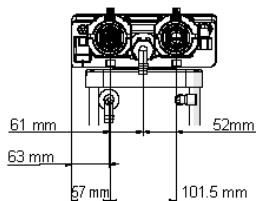
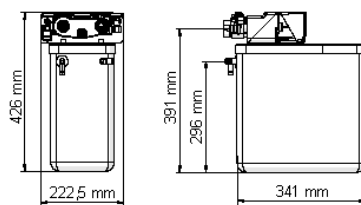

Riversoft 8

Bypass configuration

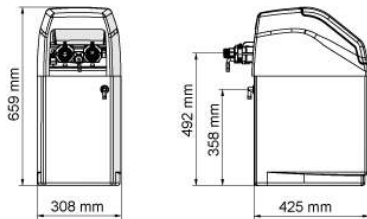

Manifold configuration

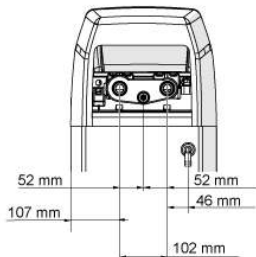
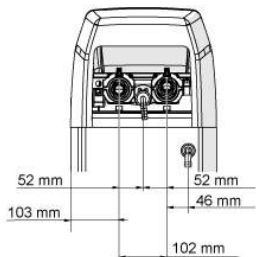
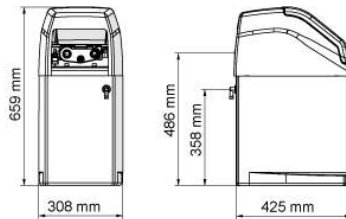

Riversoft 15

Bypass configuration

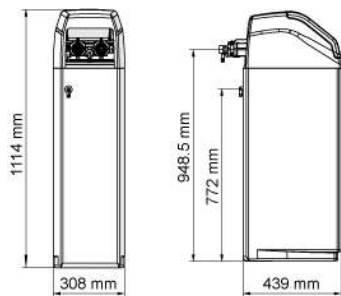

Manifold configuration

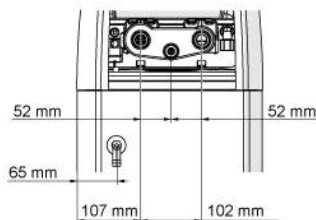
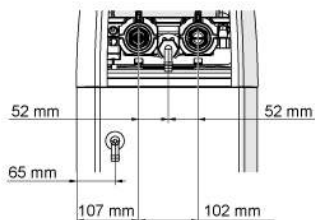
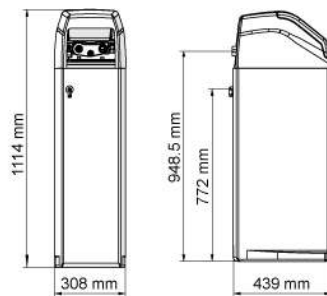

Riversoft 30

Bypass configuration

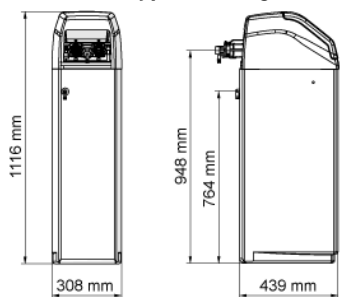

Manifold configuration

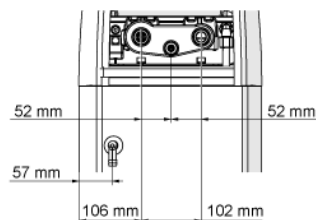
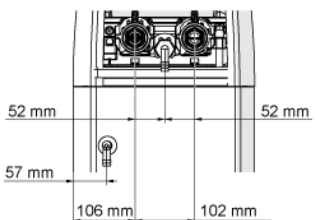
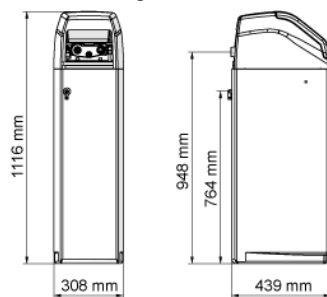

3.4 Description and component location

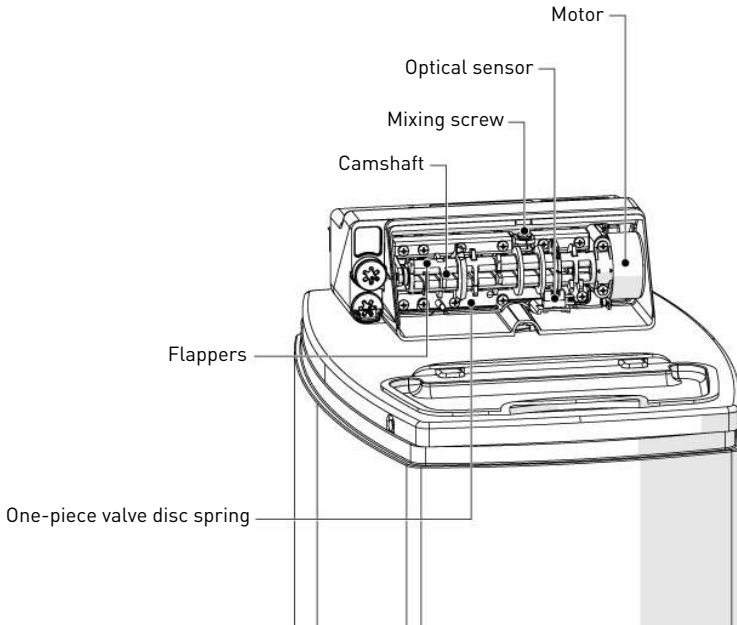
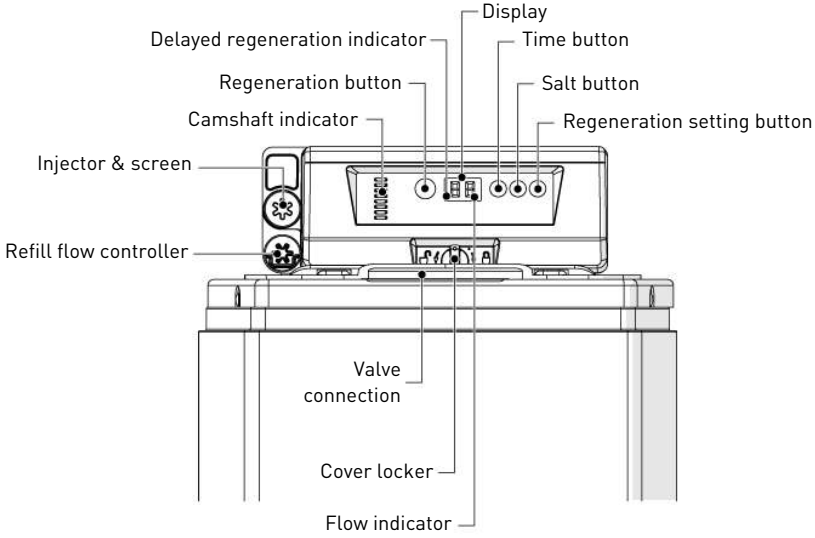

Manifold configuration

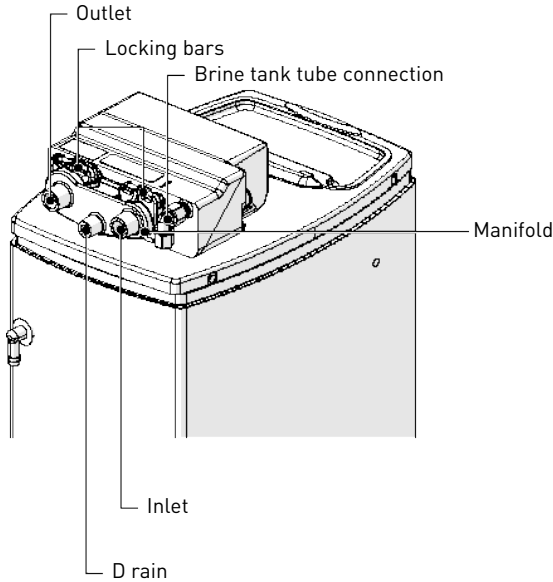

Bypass configuration

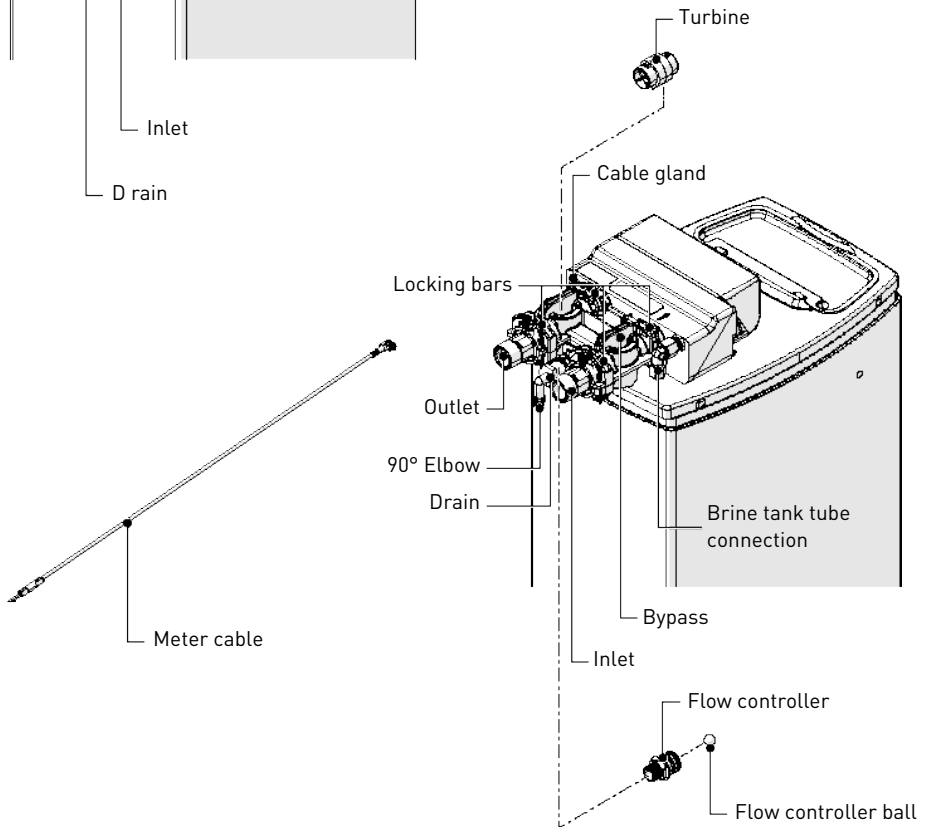

3.5 Softener's available options

3.5.1 Safety brine valve

To avoid overflow and to get a better softener operation, a safety brine valve can be installed.

1. Remove the softener covers, see Covers removal (softener and valve) [→Page 60].
2. Remove the brine well cover.
3. Remove the brine tube (P/N 3028267) and replace it with the brine valve (P/N 1036840) and its brine tube (P/N 1037194).
4. Put the brine well cover back in place.
5. Remount the softener covers, see Covers removal (softener and valve) [→Page 60].

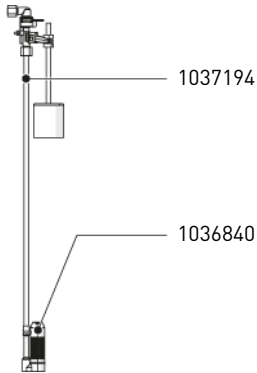

3.6 Accessories included

The following accessories are delivered with the Riversoft:

- by-pass $\frac{3}{4}$ " BSPT male (provided only for softener with bypass configuration - not provided with the manifold configuration).

4 Installation

4.1 Warnings

CAUTION



Do not lay down or flip over the softener at any time. The media may paste to the upper distributor thus obstructing its slots and may therefore compromise the softener operation.

Softener must be protected against freezing, which can cause cracking of the softener and water leakage.

4.2 Safety notices for installation

- Observe all warnings that appear in this manual;
- only qualified and professional personnel are authorized to carry out installation work.

4.3 Installation environment

4.3.1 General

- Use only regenerant salts designed for water softening. Do not use ice melt, block, or rock salts;
- keep the media tank in an upright position. Do not turn on its side, upside down, or drop it. Turning the tank upside down may cause media to enter the valve or might clog the upper screen;
- follow State and local codes for water testing. Do not use water that is micro-biologically unsafe or of unknown quality;
- when filling the media tank with water, first place the valve in the backwash position, then partly open the manual valve. Fill the tank slowly to prevent media from exiting the tank;
- when installing the water connection (bypass or manifold), first connect to the plumbing system. Allow heated parts to cool and cemented parts to set before installing any plastic parts. Do not get primer or solvent on O-rings, nuts, or the valve.

4.3.2 Water

CAUTION



Do not treat water under 1°C or over 38°C, hot water would damage the softener and void warranty.

- If you are on a private well system, check minimum water pressure with an accurate gauge (gauges on older water systems are often inaccurate). Static pressure that is less than 2 bar may cause low flow rate and inadequate regeneration, depending by the pressure drop of the system as a minimum of 1.38 bar dynamic pressure is required for the valve's injector to operate effectively.

Mandatory



Do not exceed a maximum of 8.6 bar inlet pressure. Should this happen or be subject to happen, it is necessary to install a pressure regulator upstream the system.

4.3.3 Electrical

There are no user-serviceable parts in the transformer, motor, or controller. In the event of a failure, these should be replaced.

- All electrical connections must be completed according to local codes;
- make sure power source matches the rating on the unit;
- use only the 12 VAC power supply transformer that is supplied.

Mandatory



Plug the supplied transformer in an AC 220-230 V, 50/60 Hz power supply. The use of any other power supply than the one supplied void the warranty of all electronic parts of the valve.

Mandatory



**The unit must be plugged into an outlet.
Make certain the electrical supply cannot be turned off accidentally and is not controlled by a wall switch.**

CAUTION



Due to some house using piping as a source of electrical grounding, a grounding strap must be installed when required.

Electrical components are not waterproof.

- The power outlet must be grounded;
- to disconnect power, unplug the AC cable from its power source;
- do not use any extension cord;
- locate cord where it cannot be accidentally unplugged or cause any bodily harm.

4.3.4 Mechanical

CAUTION



**Do not over-tighten the pipe to piping boss.
Do not put excessive force on the inlet, outlet or drain connections of the valve.**

Prohibition



Do not use petroleum-based lubricants such as vaseline, oils, or hydrocarbon-based lubricants.

Use only 100% silicone lubricants.

Caution - material

Risk of damage due to wrong lubricant use

Do not use petroleum-based lubricants such as Vaseline, oils, or hydrocarbon-based lubricants.

Use only approved silicone grease or soapy water!

- All plastic connections should be hand-tightened. PTFE (plumber's tape) may be used on connections that do not use an O-ring seal. Do not use pliers or pipe wrenches;
- existing plumbing should be in a good shape and free from limescale. In case of doubt, it is preferable to replace it;
- all plumbing must be completed according to local codes and installed without tension or bending stresses;
- soldering near the drain line should be done before connecting the drain line to the valve. Excessive heat will cause interior damage to the valve;
- do not use lead-based solder for sweat solder connections;
- the drain line must be a minimum of 12.7 mm (1/2") in diameter. Use 19 mm (3/4") pipe if the backwash flow rate is greater than 26.5 lpm or the pipe length is greater than 6 m;
- observe the drain line requirements: maximum 1 m high at 2 bars – 0.2 MPa inlet pressure. Add 50 cm for additional 1 bar – 0.1 MPa at the softener's inlet;
- the valve is designed for minor plumbing misalignments. Do not support the weight of the system on the valve fittings, plumbing, or the bypass;
- it is not recommended to use sealants on the threads. Use PTFE (plumber's tape) on the threads of the 25.4 mm (1") NPT elbow, the drain line connections, and other NPT/BSP threads.

4.4 Integration constraints

Location of a water treatment system is important. The following conditions are required.

CAUTION

The surface for installation (platform or floor) must be solid, flat and level.

Mandatory

Drain must be capable of handling a backwash flow rate of 19 l/min.

- Locate the softener as close as possible from drain discharge point and within 12.2 m maximum of drain discharge point, respecting minimum drain line diameter advises given at chapter Drain line connection [→Page 38];
- room to access equipment for maintenance and adding brine (salt) to tank;
- constant electrical supply to operate the controller;
- total minimum pipe run to water heater of 3 m to prevent backup of HW into system;
- always install check valve before water heater to protect the softener from HW return;

- local drain for discharge as close as possible;
- water line connections with shut off or bypass valves;
- must meet any local and state codes for site of installation;
- use flexible piping to connect main piping to softener;
- be sure all soldered pipes are fully cooled before attaching plastic valve to the plumbing.

4.5 Softener connection to piping

Tip



To prevent your softener from incoming sediment and iron particles, Pentair recommends the installation of a 100 µm pre-filter upstream the unit.

Mandatory



The unit should be installed in accordance with the manufacturer's recommendations and meet all applicable plumbing codes.

4.5.1 Block diagram

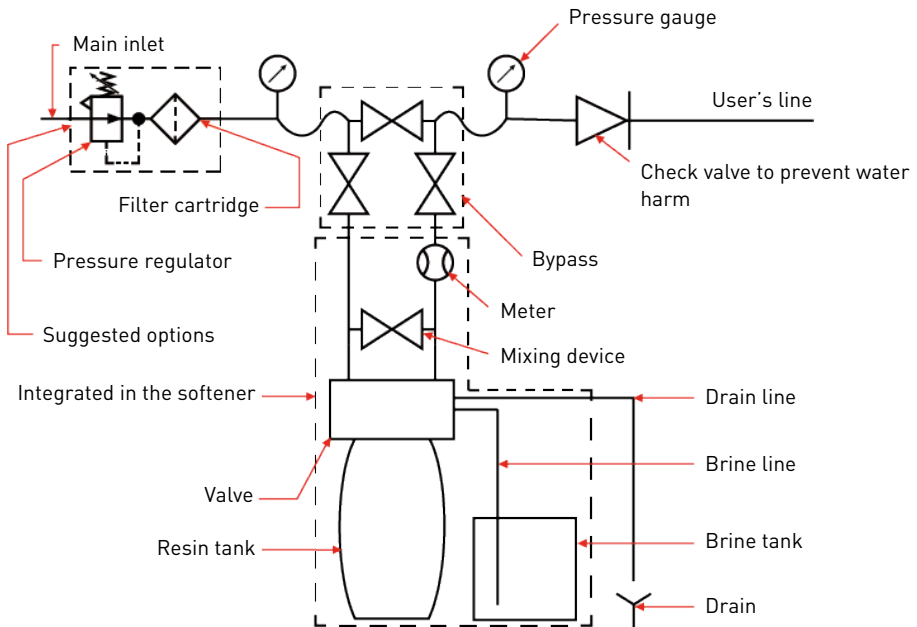

4.5.2 Installation layout

Bypass configuration

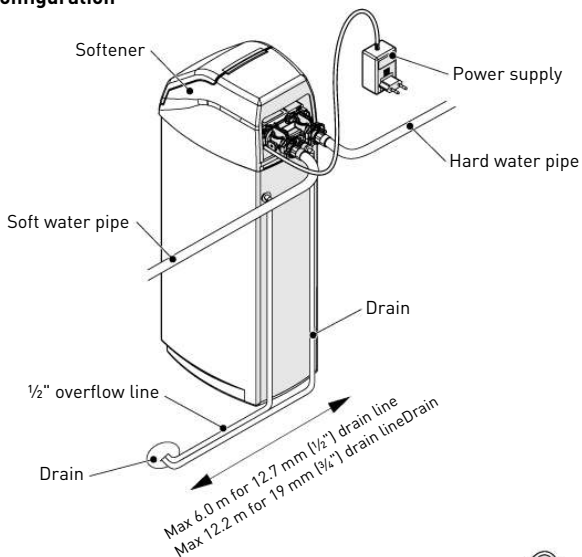

Manifold configuration

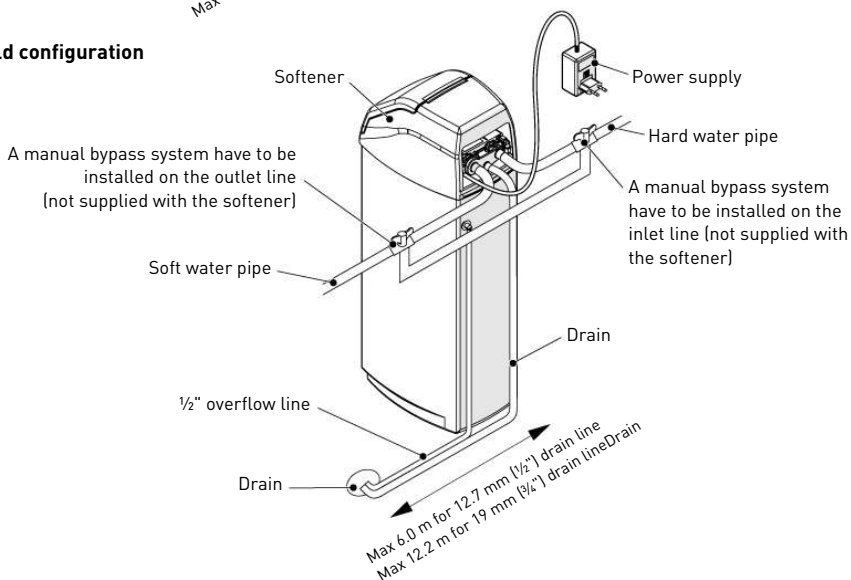

4.5.3 Tools and material required for installation

Info



Not all listed tools may be necessary for installation. Read installation procedures before starting to determine if additional tools are necessary.

Valves, grounding straps, wire, clamps and wall pipes are not supplied with the water softener.

Tip



Use ball or globe valves.

Tools:

- pipe wrenches;
- screw drivers;
- safety glasses;
- safety shoes;
- measuring tape;
- level;
- file;
- utility knife or tube cutter.

Materials:

- softener;
- pipes;
- Teflon[®] tape;
- grounding straps (optional);
- overflow pipe 1/2";
- valve drain pipe 1/2".

Material included:

- by-pass 3/4" BSPT male (provided only for softener with bypass configuration - not provided with the manifold configuration).

4.5.4 Inspection/preliminary assembly

4.5.4.1 Inspection

Mandatory



Any missing or faulty equipment must be specified on the transport documents.

- Check that all delivered equipment corresponds to the shipping list and that it is not damaged.
- Notify the transporter company and supplier immediately.

Info

In some case, some damage can only be observed when commissioning the softener.

4.5.4.2 Preliminary assembly

Info

This softener does not need any preliminary assembly.

4.5.5 Softener installation

1. Shut off power or fuel supply to water heater, see manufacturer's instructions.
2. Shut off all water at main supply water line.
3. Open highest and lowest faucet of the line where softener will be installed to relieve pressure and drain the system.
4. Set the unit in place, see Softener connection to piping [[→Page 28](#)] and Installation layout [[→Page 29](#)].
5. Place the softener in a firm concrete floor or slab base. Be sure the unit is reasonably level.

CAUTION

Do not shim the softener directly for levelling. If necessary to shim, fabricate a platform base to set the tank on and then shim under the platform base.

6. Make necessary piping changes for connecting the softener inlet and outlet to the home piping. Make sure not to reverse inlet and outlet.
7. Installation of supplied bypass is highly recommended, see Bypassing [[→Page 34](#)].
8. Connect the inlet and outlet piping, see Water supply line [[→Page 32](#)].

Info

The valve connection threads are 3/4" BSPT male.

Mandatory

Make sure having the incoming water connected to the left side (looking from the front of the softener).

Mandatory

Do not use pipe joint compound or plumber's putty on the valve body threads and do not over-tighten fitting.

Use only Teflon[®] tape.

9. Make certain proper piping alignment is maintained. Do not apply heat to any fitting connected to the softener or damage to the valve may occur.
10. Move the softener in position and level.

Tip

To prevent water leaks, connections to the softener must be straight when the softener is levelled.

11. Carefully connect the valve drain line at the back of the softener, see Drain line connection [→Page 38].
12. Connect salt storage tank overflow elbow to drain, see Overflow line connection [→Page 39].

⚠ CAUTION

Do not connect valve drain line and overflow drain line together by teeing.

4.5.6 Water supply line and bypass connections

4.5.6.1 Water supply line

The connections should be hand tightened using PTFE (plumber's tape) on the threads if using the threaded connection type.

In case of heat welding (metal type connection), the connections should not be made to the valve when soldering.

Info

See chapter Description and component location [→Page 22] to identify the connections.

When pressurized, any composite tank will expand both vertically and circumferential. In order to compensate the vertical expansion, the piping connections to the valve must be flexible enough to avoid overstress on the valve and tank.

In addition, the valve and tank should not be supporting any part of the piping weight. This is hence compulsory to have the piping fixed to a rigid structure (e.g. frame, skid, wall...) so that the weight of it is not applying any stress on the valve and tank.

Bypass configuration

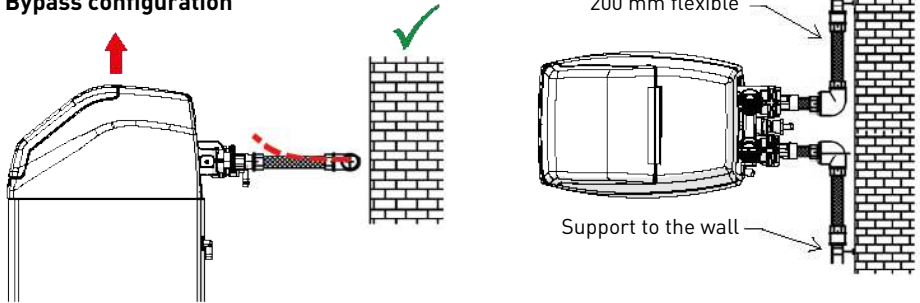

Manifold configuration

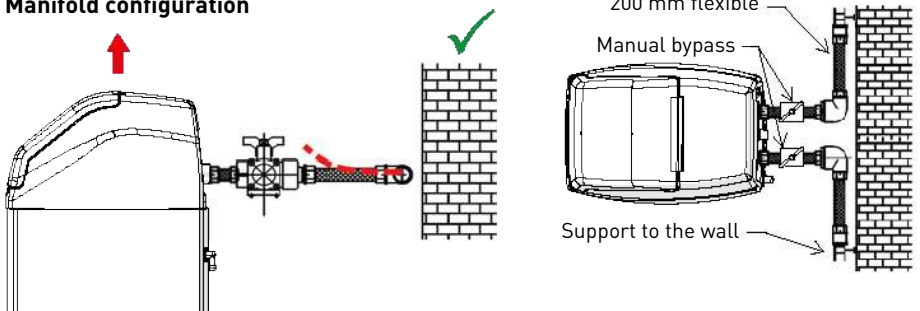

- The diagrams above illustrate how the flexible piping connection should be mounted;
- in order to adequately compensate the tank elongation, the flexible tubes must be installed **horizontally**;
- should the flexible piping connection be installed in vertical position, instead of compensating the elongation, it will create additional stresses on the valve & tank assembly. Therefore, this is to be avoided;
- the flexible piping connection must also be installed stretched, avoiding excessive length. For instance 20 - 40 cm is enough;
- excessively long and non-stretched flexible piping connection will create stresses on the valve and tank assembly when the system is pressurized, as illustrated in the below picture: on the left the assembly when the system is unpressurized, on the right the flexible piping connection when put under pressure tends to lift up the valve when stretching up. This configuration is even more dramatic when using semi-flexible piping;
- failure to provide enough vertical compensation may lead to different kinds of damage, either on the valve thread which is connected to the tank, or on the female thread connection of the tank. In some cases, damage may also be seen on the valve inlet and outlet connections;

Bypass configuration

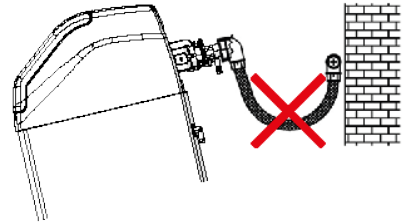
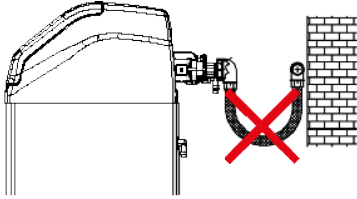

Manifold configuration

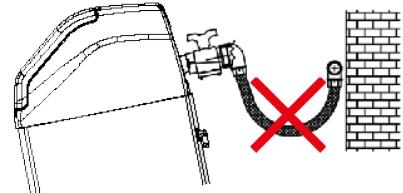
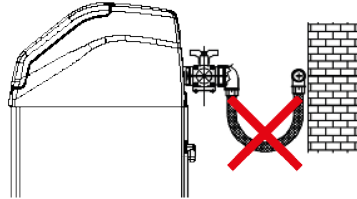

- in any case, any failure caused by improper installations and/or piping connections may void the warranty of Pentair products;
- in the same way, using lubricant* on the valve thread is not allowed and will void the warranty for the valve and tank. Indeed, using lubricant there will cause the valve to be over-torqued, which may lead to valve thread or tank thread damage even if the connection to piping has been done following the above procedure.

*Note: do not use petroleum or hydrocarbon-based lubricants. Using these types of lubricants will structurally damage valve and cause failures. Use only 100 % silicone lubricants.

4.5.6.2 Bypassing

- Softener with bypass configuration: a bypass valve system is provided with the installation kit;
- softener with manifold configuration: a bypass valve system has to be installed upstream the installation (not provided in the installation kit).

A bypass valve system should be installed on all water conditioning systems. Bypass valves isolate the softener from the water system and allow unconditioned water to be used. Service or routine maintenance procedures may also require that the system is bypassed.

Bypass configuration

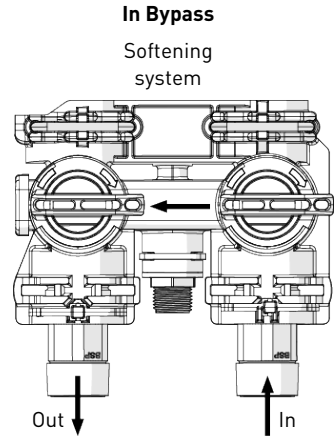
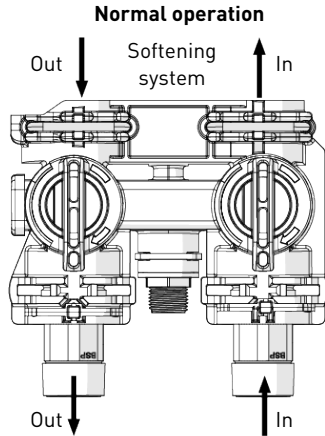

Manifold configuration

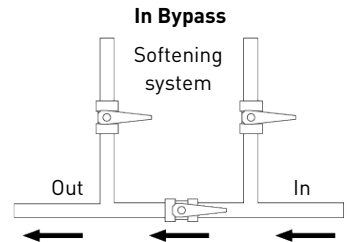
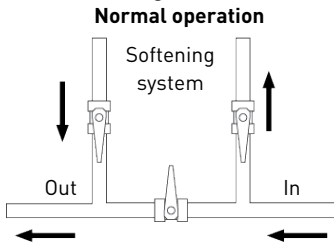

Caution - material



Risk of damage due to bad mounting!

Do not solder pipes with lead-based solder.

Do not use tools to tighten plastic fittings. Over time, stress may break the connections. When the bypass valve is used, only hand tighten the plastic nuts.

Do not use petroleum grease on gaskets when connecting bypass plumbing. Use only 100% silicone grease products when installing any plastic valve. Non-silicone grease may cause plastic components to fail over time.

4.5.6.3 Bypass assembly

Info



The following procedure is only valid for softener with bypass configuration.

The bypass assembly connects to the water system by means of a connector assembly. The connector is secured to the plumbing and then inserted into the bypass. Clips are used to hold it in place.

Before inserting the connector:

- check that all o-rings are in place and not damaged;
 - o-rings are pre-lubricated. Sliding surfaces should be lubricated with 100% silicone grease.
1. Firmly insert connector (3) into bypass.
 2. Press the locking clip (1) into position. Make certain the clip is fully engaged.

⚠ CAUTION



Before turning on the water to the valve, rotate the two handles (4) on the bypass valve 2 or 3 times.

This will help to place the O-rings and prevent leaking.

To remove a clip:

1. Turn off water and release water pressure at the valve.
2. Push the water line connectors (3) into the bypass and valve. This will help release O-rings that may have seated in place.
3. Remove the clips (1) by inserting a flat screwdriver (2) under the top centre of the clip and lifting (prying up).

Caution - material



Do not use pliers to remove a clip.

It is likely the clip will break.

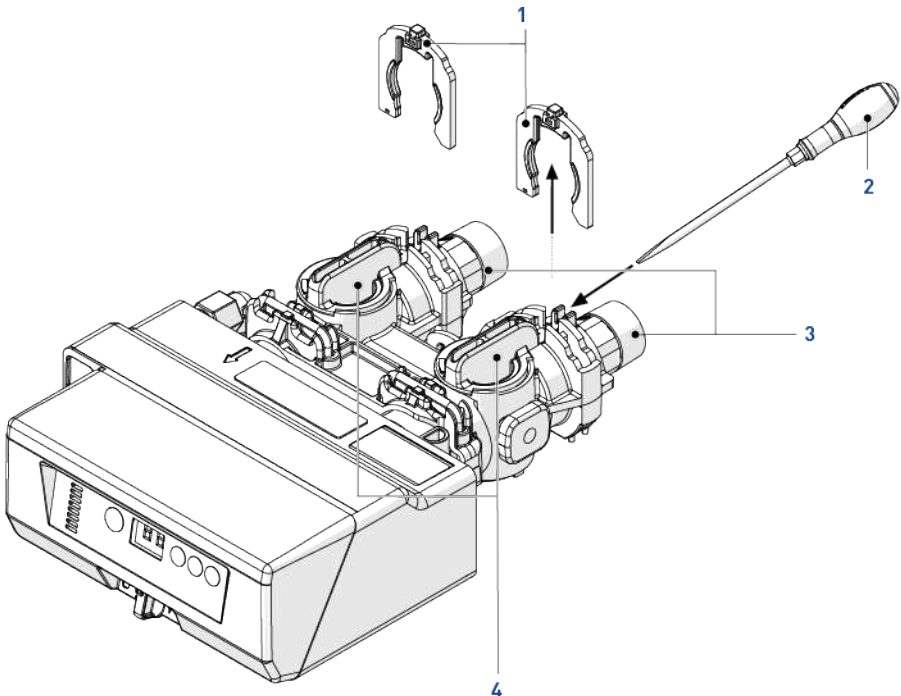

4.5.6.4 Bypass tips

- Before removing a clip on the softener, shut off water supply and relieve system pressure. Do not forget to put back the clip on the softener before opening water supply.
- You can use a clip to open/close the bypass more easily.

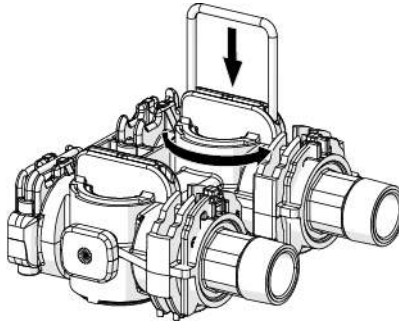

4.5.7 Drain line flow controller

The DLFC requires assembly before use.

Info



Note

The plumbing connectors should not be installed. See Bypassing [→Page 34].

1. Using a PTFE (plumber's tape), wrap it over threads of the flow controller (2).
2. Screw the flow controller (2) and the 90° elbow (1) together (hand tighten).
3. Place the ball (5) into the flow controller (2) and insert the assembly into the drain line opening (4).
4. Push the assembly in and secure with the drain line clip (3).

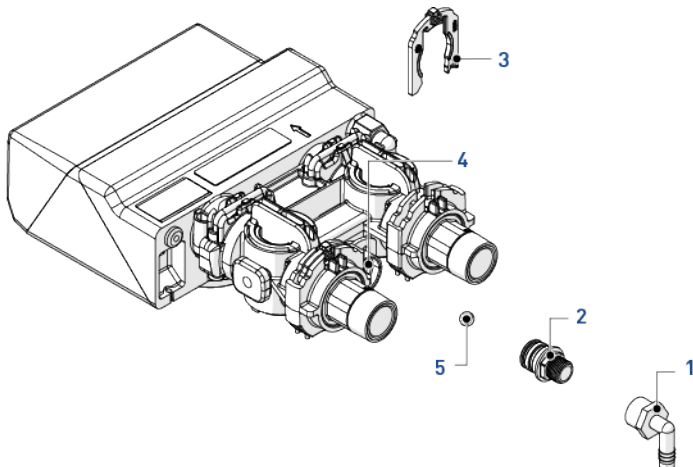

4.5.8 Drain line connection

Info



Standard commercial practices are expressed here.

Local codes may require changes to the following suggestions.

Check with local authorities before installing a system.

CAUTION



The drain line plastic elbow must always be hand-tighten without using the elbow as a lever.

The drain plastic elbow is not designed to support the weight of the tube. The tube has to have its own support.

Do not overtighten the tube on the drain line plastic elbow.

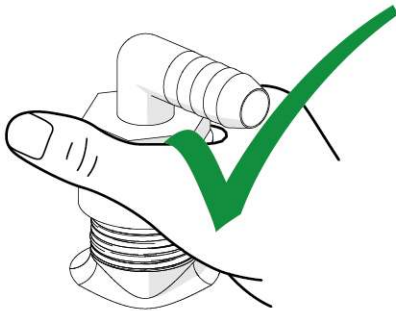

If available, use a floor drain or sump drain, but it is also possible to use a sump pit, dry well, clothes washer drain, laundry tube or sanitary sewer line with sink type trap.

The drain line should be as short as possible and the unit should not be more than 12.2 m from the drain. Use an appropriate adapter fitting to connect a 12.7 mm (1/2") plastic tubing to the drain line connection of the valve if the drain line is shorter than 6 m. Use a 19 mm (3/4") tubing if the drain is longer than 6 m or if the backwash flow rate is greater than 22.7 l/min.

Use appropriate fittings to connect the 19 mm (3/4") tubing to the drain connection on the valve.

Where the drain line is elevated but empties into a drain below the level of the valve, form a 18 cm loop at the far end of the line so that the bottom of the loop is level with the drain line connection. This will provide an adequate siphon trap.

Where the drain empties into an overhead sewer line, a sink-type trap must be used.

Also select a firm hose that will not soften and collapse or shrink at high temperature, at suspension points or at sharp bends. Clamp the drain line securely to a rigid surface to prevent it from moving during regeneration.

Info



Plumbing codes do not allow a direct connection into any sanitary or storm drain, sewer line trap.

Waste connections or the drain outlet shall be designed and constructed to provide connection to the sanitary waste system through an air gap of at least 5 cm.

This is usually required so sewer backup will not be back-siphoned into the softener.



CAUTION

When running the drain line to a floor drain, the area around the drain may become wet during the regeneration process.

Keep floor drain area clean at all times to prevent any damage.

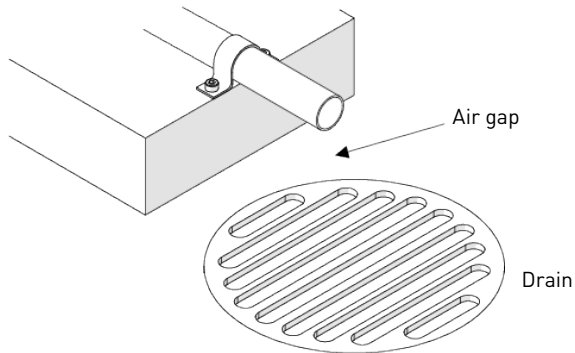

4.5.9 Overflow line connection

In the event of a malfunction, the brine tank overflow fitting will direct “overflow” to the drain instead of spilling on the floor. This fitting is at the back of the cabinet.

To connect the overflow line, locate the barbed elbow at the back of the cabinet and connect a 1/2" tubing (not supplied) from the elbow to the drain.

Do not elevate overflow higher than overflow fitting.

Do not tie into drain line of softener. Overflow line must be a direct, separate line from overflow fitting to drain, sewer or tub. Allow an air gap as per drain line instructions.

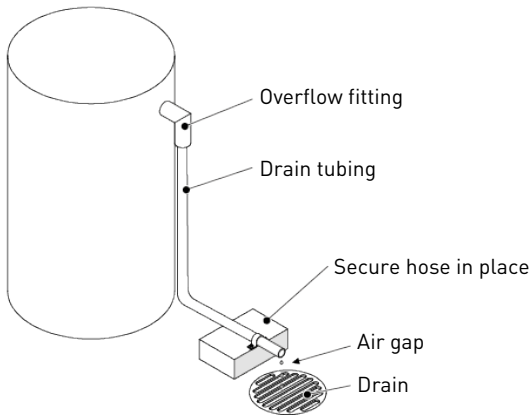

Caution - material



Risk of flooding due to lack of floor drain!

Floor drain is always recommended to avoid flooding in case of overflow.

4.6 Electrical connection

4.6.1 Meter connection

Info



During shipping, the cable from the back of the controller to the meter assembly may have been disconnected. If it has, insert the end of the cable into the top of the meter assembly (1).

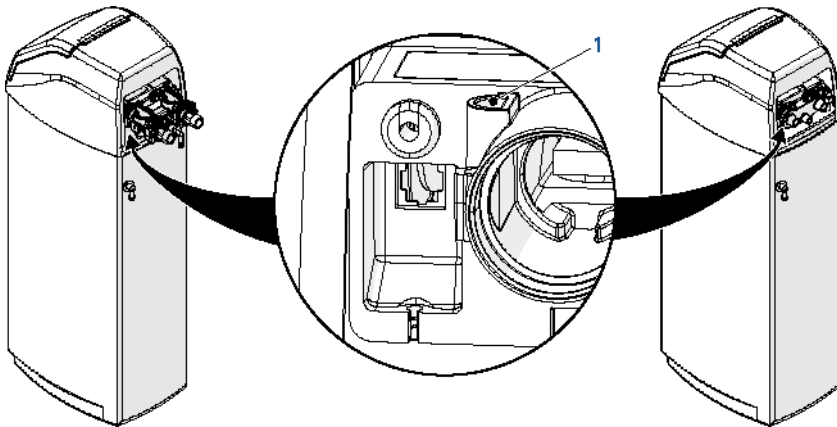

4.6.2 Controller connection

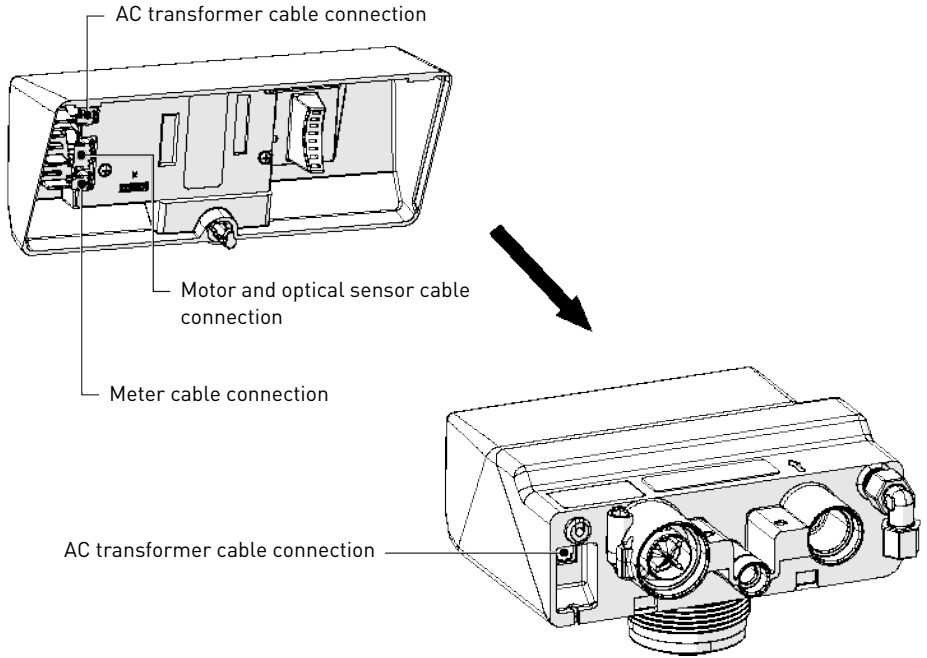

5 Programming

Info



Note

Menus are displayed in a defined and incremental order. After 5 seconds without keypad input, the unit returns to normal operation mode and display the time of day.

Info



Memory retention in case of power failure

The controller stores the time of day without battery in case of power failure. All others pro-programmed parameters are stored in the non-volatile (Novram) memory and are stored during power failure. The storage time in the flash memory is about 99 years.

5.1 Display

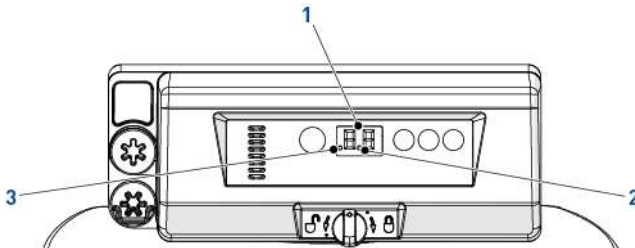



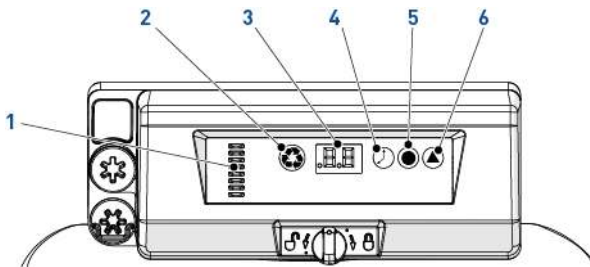

- | | |
|-----------------------------------|---|
| 1. Digits | Two digits used to display the time, program value or error codes. |
| 2. Flow indicator | The flow indicator blinks ON and OFF when water flow turns the meter. |
| 3. Delayed regeneration indicator | When this dot is displayed, it means that a delayed regeneration is programmed. |

5.2 Commands



- | | |
|-----------------------|---|
| 1. Camshaft indicator | A column of windows provides a visual indicator of the camshaft rotation. |
|-----------------------|---|

2.  - Manual regeneration button
The manual regeneration button when pressed initiates either a delayed regeneration or immediate regeneration.
3. Display
Used to show informations, see Display [→Page 42].
4.  - Time button
The time button when pressed will display the current hour of day for 5 seconds.
Also used to change the time of day [→Page 43].
5.  - Salt button
The salt button when pressed will display the current salt setting for 5 seconds.
Also used to change the brine dosage [→Page 44].
6.  - Hardness button
The hardness button when pressed will display the current hardness setting for 5 seconds.
Also used to change the volumetric regeneration [→Page 44].

5.3 Quick program guide

Parameter description	Range of values	Default value	Units of measure	Notes
Time of day	0:00 - 23:59	12:00	hour: minute	
Brine dosage	0.2 - 6.0	0.6	kg	From 0.2 kg to 1.0 kg by increments of 0.05 kg; from 1.0 kg to 3.0 kg by increments of 0.1 kg; from 3.0 kg to 6.0 kg by increments of 0.5 kg.
Volumetric regeneration	0.4 - 9.5	3.6	m ³	From 0.4 m ³ to 1.0 m ³ by increments of 0.05 m ³ ; from 1.0 m ³ to 3.0 m ³ by increments of 0.1 m ³ ; from 3.0 m ³ to 5.0 m ³ by increments of 0.2 m ³ ; from 5.0 m ³ to 9.5 m ³ by increments of 0.5 m ³ .
Calendar override	0 - 30	3	day	0 = Disabled; 0.3 = Regeneration every 8 hours: at 2, 10 and 18 hours; 0.5 = Regeneration every 12 hours: at 2 and 14 hours; 1 - 30 = Regeneration every X days.
System selection	1 - 4	1	-	See Regeneration cycles time [→Page 45].

5.4 Time of day

Set the current time.

1. Press  until desired hour appears then release.
 - ⇒ Range from 0 through 23 hours.
 - ⇒ The elapsed minutes will reset to zero when the hours are changed.

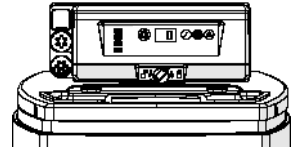

5.5 Brine dosage

Set the brine dosage.

1. Press  until desired brine dosage appears then release.
 - ⇒ Range from 0.2 kg to 6.0 kg;
 - from 0.2 kg to 1.0 kg by increments of 0.05 kg;
 - from 1.0 kg to 3.0 kg by increments of 0.1 kg;
 - from 3.0 kg to 6.0 kg by increments of 0.5 kg.

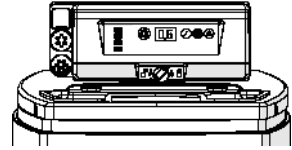

5.6 Volumetric regeneration

Set the capacity in [m³] between each regeneration.

1. Press  until desired capacity appears then release.
 - ⇒ Range from 0.4 to 9.5 m³;
 - from 0.4 m³ to 1.0 m³ by increments of 0.05 m³ (12 increments);
 - from 1.0 m³ to 3.0 m³ by increments of 0.1 m³ (20 increments);
 - from 3.0 m³ to 5.0 m³ by increments of 0.2 m³ (10 increments);
 - from 5.0 m³ to 9.5 m³ by increments of 0.5 m³ (10 increments).

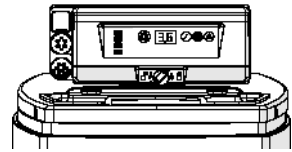

5.7 Time clock regeneration (Riversoft 4 only)

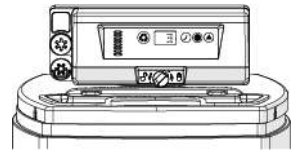

Set the time between each regeneration.

1. Press  until desired interval appears then release.
 - ⇒ Range from 0 through 30;
 - 0 = Disabled;
 - 0.3 = Regeneration every 8 hours: at 2, 10 and 18 hours;
 - 0.5 = Regeneration every 12 hours: at 2 and 14 hours;
 - 1 - 30 = Regeneration every X days (every 3 days in this example).



5.8 Calendar override setting

The controller needs a method to set days between regeneration for regulatory requirements and in cases when the flow sensor has failed.

1. Press and hold  and  for 3 seconds.
 - ⇒ The programmed calendar override is displayed.
1. Press  to increase value.

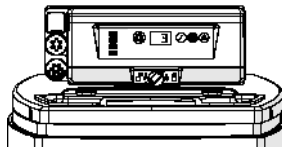



- ⇒ Range from 0 through 30;
 - 0 = Disabled;
 - 0.3 = Regeneration every 8 hours: at 2, 10 and 18 hours;
 - 0.5 = Regeneration every 12 hours: at 2 and 14 hours;
 - 1 - 30 = Regeneration every X days (every 3 days in this example).

5.9 System selection

The controller has four system settings available. The system selections accommodate multiple tank sizes and various feedwater conditions.

System selection:

1. Press and hold  and  simultaneously for 3 seconds.
 - ⇒ A small "u" will be displayed in the left digit.
 - ⇒ The right digit will display the current system setting.
1. Press  until desired system setting appears then release.
 - ⇒ The displayed system setting will be stored in flash memory when the controller exits programming after 5 seconds.

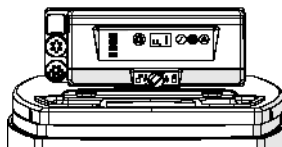

5.10 Regeneration cycles time

C#	Cycle	Resin bed flow direction	System u# [minutes]			
			u1	u2	u3	u4
C1	Backwash	↑	8	8	1	3
C2	Brine draw	↓	Calculated	Calculated	Calculated	Calculated
	Slow rinse		25	45	25	45
C3	Repressurize	None	3	3	3	3
C4	Rapid rinse	↓	3	3	1	3
C5	2nd backwash	↑	1	1	1	1
C6	2nd rapid rinse	↓	1	1	1	1

C#	Cycle	Resin bed flow direction	System u# [minutes]			
			u1	u2	u3	u4
C7	Brine refill	None	Calculated	Calculated	Calculated	Calculated

5.11 History values

The controller features a review level that displays the operation history of the system. To access history values:

1. Press and hold and simultaneously for 3 seconds.
 - ⇒ To view the "H" levels.
1. Press to navigate through the table.
 - ⇒ When the desired code is reached, press to display the value.
 - ⇒ Some of the values have four digits. Press to display the first two digits, then press to display the last two digits.

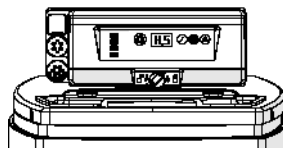

Info



Note



After 30 seconds without a button press, the controller exits the history table.

Code	Description	Notes
H1	Days since last regeneration	Days since last regeneration.
H2	Current day of week	0-6.
H3	Water used today since 02h00	In liter.
H4	Water used since last regeneration	In liters,
A0	Average water usage for day 0	max value displayed 9999, max value stored 65 535.
A1	Average water usage for day 1	
A2	Average water usage for day 2	
A3	Average water usage for day 3	
A4	Average water usage for day 4	
A5	Average water usage for day 5	
A6	Average water usage for day 6	

5.12 Resetting the controller and system selection (u1 to u4)

All programmed settings with the exception of time of day can be reset. Entering the value "0" will reset the flash memory to the factory default.

To reset the controller:

1. Press and hold  and  simultaneously for 3 seconds.
 - ⇒ A small "u" will be displayed in the left digit.
 - ⇒ The right digit will display the current system setting.
1. Press  until the "u0" system is displayed.
 - ⇒ Wait 5 seconds for the setting to be stored into the flash memory. The display will return to the time of day.
 - ⇒ The controller has now system 1 setting (default setting).
1. Follow the steps of the system selection procedure to select the desired system setting [System selection [→Page 45]].

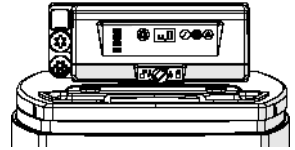

6 Commissioning

6.1 Softener commissioning

6.1.1 Water filling, draining and waterproofness inspection

Once the previous initial programming steps are performed, that the softener is in place and hydraulically connected to the main water line (see Softener installation [→Page 31]), the unit can be started up.

⚠ CAUTION



Do not rotate the camshaft by hand or damage to the unit may occur. Use the controller to take the camshaft electronically through the cycles.

Follow these steps carefully:

1. With the main water supply closed, open the nearest faucet downstream the unit and the upper one on the line if not still open from installation step (Softener installation [→Page 31]).
2. With the supply water for the system still turned off, position the bypass valve to the "non-bypass" (normal operation) position for the inlet side, while the outlet stay in bypass position.

Bypass configuration

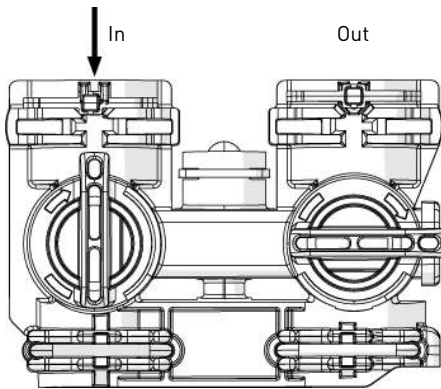

Manifold configuration

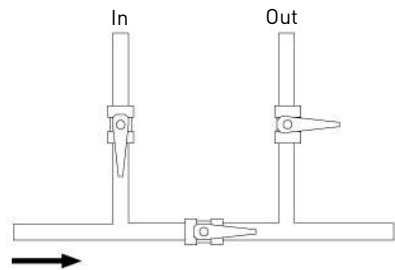

3. Press  on the controller for 3 seconds. This will initiate a manual regeneration. The controller will activate the motor and turn the camshaft to cycle C1 (Backwash) position. The controller will display the total regen time remaining in the current cycle.
4. Fill the media tank with water.
 - ⇒ While the controller is in cycle C1 (Backwash), open the water supply valve very slowly to approximately the ¼ open position.

⚠ CAUTION



If opened too rapidly or too far, media may be lost out of the tank into the valve or the plumbing. In the ¼ open position, you should hear air slowly escaping from the valve drain line.



- ⇒ Unplug the power transformer from the socket so that the valve remains in backwash position.
- ⇒ When most of the air has been purged from the media tank (water begins to flow steadily from the drain line), open the main supply valve all of the way. This will purge the remaining air trapped in the tank.
- ⇒ Allow water to drain out until the water runs clear from the drain line. This also purges any debris resulting from installation and piping work from the media bed.
- ⇒ Turn off the water supply and let the system stand for about 5 minutes. This will allow any still trapped air to escape from the tank.
- ⇒ Turn the water on again and plug the power transformer back into its electrical socket.

Info



Do not put salt into the tank before the valve has been started up. With no salt in the tank, it is much easier to view water flow and motion.





6.1.2 Quick cycling



1. Quick cycle the valve until C7 (refill cycle) by pressing  and  at each cycle and leave the valve in refill position to prime the line between the brine tank and the valve.

Info



As you advance through each cycle there will be a slight delay before you can advance to the next cycle. There may be a pause at cycle C3 (System Pause). This cycle allows the water/air pressure to equalize on each side of the valve discs before moving on.

- ⇒ With the water supply still completely open, let the water flow through the line until the end of C7 (refill cycle) so that all air bubbles have been purged from the line and the required water for 1st brine preparation is in the brine tank already.
 - ⇒ Mark the level of water in the brine tank.
 - ⇒ Once the air is purged from the line, press  and  simultaneously to advance to cycle C0 (Treated Water) position.
2. Draw water from the brine tank.
 - ⇒ From the treated water position (cycle C0), manually start a regeneration and advance the valve to the draw brine position.
 - ⇒ Press  for 3 seconds. The controller will begin a manual regen, and advance the valve to the cycle C1 (Backwash). Press  and  to advance to cycle C2 (Draw).
 - ⇒ With the controller in this position, check to see that the water in the brine tank is being drawn out of the tank. The water level in the tank should recede very slowly.
 - ⇒ Observe the water being drawn from the brine tank for at least 3 minutes. If the water level does not recede, or goes up, check all hose's connections. C2 should be displayed.

If the water level is receding from the brine tank you can then advance the controller back to the treated water (C0) position by pressing  and  simultaneously for 5 seconds to advance the controller to the C0 position.

6.1.3 Startup

1. Finally, if not already done, turn on a faucet plumbed after the water softener and slowly open the outlet bypass side to place the bypass into normal operation position. Run the faucet until the water runs clear and then close it. With a bucket fill brine tank with water up to the mark done at step 1 of Quick cycling [→Page 49]. Add salt to the brine tank. Make sure to respect the maximal salt load for your model.
2. Set up the float level between 3 to 5 cm above the level of water in the brine tank and maximum up to 1-3 cm below the overflow elbow.
3. The softener is now in service. Check residual hardness at the nearest faucet downstream the softener, if necessary, adjust the mixing screw (1) setting iteratively until the residual hardness correspond to the value used when programming the hardness parameter.

Info



Pentair advise to set a residual hardness between 50 and 100 mg/l of CaCO_3 .

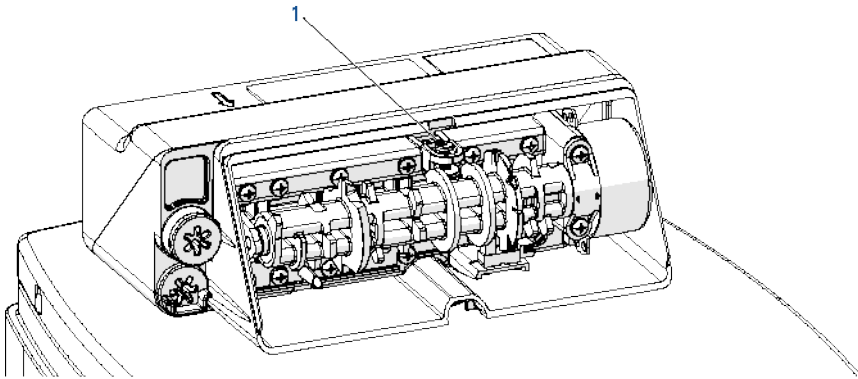

6.1.4 Additional tips

- When the controller is first plugged in, it may display a flashing hourglass and the message "Err 3", this means that the controller is rotating to the home position. If the "Err 2" is displayed, check that the incoming power frequency matches the controller;
- the preset default time of regeneration is 2:00 AM;
- power supply: The World controller senses the electrical input and decides which is needed;
- if electrical power is not available, the camshaft can be rotated counter-clockwise by hand if the motor is removed;
- the controller sends commands to the motor for camshaft movement. However, water pressure/flow are required during the regeneration cycle for backwash, purge and refill, and brine draw to actually take place;
- make sure the control power source is plugged in. The transformer should be connected to a non-switched power source;
- you can start programming from the beginning by resetting the controller, see chapter Resetting the controller and system selection (u1 to u4) [→Page 46].

6.2 Cleaning, disinfection and sanitization

The construction materials of the modern water softener will not support bacterial growth, nor will these materials contaminate a water supply. During normal use, a softener may become fouled with organic matter, or in some cases with bacteria from the water supply. This may result in an off-taste or odour in the water. In this case, the tank of the softener must be cleaned and disinfected.

Some softeners may need to be disinfected after installation and some softeners will require periodic disinfection during their normal lifetime.

Depending on the conditions of use, the softener type, the type of ion exchanger, and the disinfectant available, a choice can be made among the following methods.

6.2.1 Cleaning of softeners

Make sure the brine tanks remains free from debris, waste, scraps that could be drown in the valve during brine draw cycles of regenerations. Make sure the softener and its parts remains clean to ensure proper function. Note that camshaft positioning is made by a optical sensor. Should this optical sensor be obstructed, malfunctions may happen.

6.2.2 Disinfection with sodium or calcium hypochlorite

These materials are satisfactory for use with polystyrene resins, synthetic gel zeolite, greensand and bentonites.

6.2.2.1 5.25 % Sodium hypochlorite

If stronger solutions are used, such as those sold for commercial laundries, adjust the dosage accordingly.

Dosage

Polystyrene resin: set 1.25 ml per liter of resin.

Brine tank softeners

Backwash the softener and add the required amount of hypochlorite solution to the well of the brine tank. The brine tank should have water in it to permit the solution to be carried into the softener.

Proceed with the normal regeneration.

6.2.2.2 Calcium hypochlorite

Calcium hypochlorite, 70 % available chlorine, is available in several forms including tablets and granules. These solid materials may be used directly without dissolving before use.

Dosage

Measure 0.11 ml per liter of resin.

Brine tank softeners

Backwash the softener and add the required amount of hypochlorite to the well of the brine tank. The brine tank should have water in it to allow the chlorine solution from being carried into the softener.

Proceed with the normal regeneration.

7 Operation

7.1 Display

7.1.1 During operation

- The current time in 24 hours is displayed on 2 digits (minutes are not displayed).
- The flow indicator blinks ON and OFF when water is flowing.

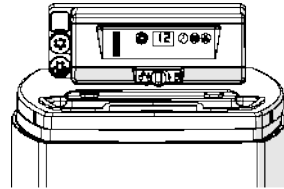

7.1.2 During regeneration

- The controller will display a cascading symbol "--" until regeneration is complete.
- If a button is pressed the current time and cycle will be displayed alternately.

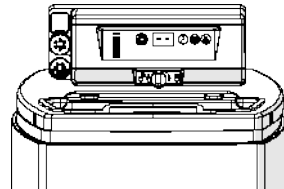

7.2 Manual regeneration

Mandatory



The controller must be in service in order to enable this procedure.

Info



Note

The unit returns to normal operation if no buttons are pressed within 30 seconds.

7.2.1 Manual delayed regeneration

1. Press  once for delayed regeneration.
 - ⇒ The regeneration will start on the scheduled time. See Display [→Page 42].
 - ⇒ The regeneration dot will blink when delayed regeneration is on.

Info



Note





To cancel: press  again. The regeneration dot disappears.

7.2.2 Immediate regeneration



1. Press and hold  for 3 seconds to initiate immediate manual regeneration.
 - ⇒ The controller will display a cascading symbol "--" as it cycles to backwash.

⇒ The controller will proceed through a complete regeneration.

7.2.3 To advance regeneration cycles

1. Simultaneously press  and  to advance to the next cycle.
 - ⇒ When the camshaft reaches the next cycle, "C#" will be displayed.
2. Repeat  and  to advance through each cycle.

7.2.4 To cancel a regeneration

1. Press and hold  and  for 3 seconds during any regeneration cycle to cancel it.
 - ⇒ The controller will skip the remaining regeneration cycles and return to the service position. It may take 1 to 2 minutes.
 - ⇒ The time of day will be displayed when the controller reaches the service position.

7.3 Operation during a power failure

- All the program settings are stored in a permanent memory (NOVRAM);
- current valve position, cycle step time elapsed, and time of day are stored during a power failure, and will be restored upon power restoration;
- time of day/day of week is kept during a power outage thanks to a supercapacitor as long as the power is restored within 8 hours and the supercapacitor was fully charged. Multiple power shutdown in a short period may decrease the supercapacitor charge;
- the time of day on the main display screen will flash for 5 minutes when there has been a power failure. The flashing of the time of day can be stopped by pressing any button on the display;
- should the power failure be longer than 8 hours, the display will show "0". To show the time, it must be set up again and restart internally as if it was 12:00 when power was restored.

8 Maintenance

Mandatory



Cleaning and maintenance shall take place at regular intervals in order to guarantee the proper functioning of the complete system, and be documented in the Maintenance chapter in the User Guide document.

Mandatory



The maintenance and service operation must be done by qualified personnel only.

Failure in respecting this may void the warranty.

8.1 General system inspection

Tip



Has to be done once a year at minimum!

Disinfect and clean the system at least once a year or if the treated water has an off-taste or an unusual odour.

8.1.1 Water quality

1. Raw water total hardness.
2. Treated water hardness.

8.1.2 Mechanical checks

1. Inspect general condition of valve and associated ancillaries and check for any leaks, ensure valve connection to piping is made with adequate flexibility as per manufacturer instruction.
2. Inspection of electrical connections, verify wiring connections and search for evidence of overloading.
3. Verify settings of electronic or electromechanical timer, verify regeneration frequency, make sure the valve configuration corresponds to the settings.
4. Check water meter, if present, report water meter settings, compare with previous inspection.
5. Verify total water consumption compared to previous visit.
6. If pressure gauges are installed before and after softening system, verify and record static and dynamic pressure, reporting pressure drop. Verify that inlet pressure respects valve and softening system limits.
7. If pressure gauges are not present, but suitable points exist, install temporary pressure gauge(s) to perform precedent point.

8.1.3 Regeneration test

1. Check condition of brine tank and any associated equipment.
2. Check salt level in brine tank.
3. Initiate regeneration test.
 - ⇒ Check brine draw during brine draw stage.
 - ⇒ Check brine tank refill.
 - ⇒ Check operation of safety brine valve, where fitted.
 - ⇒ Check for brine draw off levels.
 - ⇒ Check for resin loss at the drain during regeneration.
 - ⇒ Where fitted, check for satisfactory operation of solenoid, i.e. outlet shut off during regeneration and/or brine line shut off valve(s).
4. Test and record Total Hardness of outlet water from softener vessel(s).

8.2 Recommended maintenance plan

Items	1 year	2 year	3 year	4 year	5 year
Injector & filter	Clean	Clean	Clean	Clean	Clean/replace if necessary
Refill controller & ball **	Clean	Clean	Clean	Clean	Clean/replace if necessary
DLFC & ball **	Clean	Clean	Clean	Clean	Clean/replace if necessary
Aircheck & balls ***	-	-	-	-	Clean/replace if necessary
Bypass	-	-	-	-	Clean/replace if necessary
Flappers **	-	-	-	-	Replace
Flappers spring	-	-	-	-	Replace
O-rings**	Check for watertightness /clean or replace in case of leakage	Check for watertightness /clean or replace in case of leakage	Check for watertightness /clean or replace in case of leakage	Check for watertightness /clean or replace in case of leakage	Check for watertightness /clean or replace in case of leakage
Motor, motor cable and optical sensor harness	Check	Check	Check	Check	Replace
Optical sensor	Check	Check	Check	Check	Replace
Inlet hardness	Check	Check	Check	Check	Check

Items	1 year	2 year	3 year	4 year	5 year
Residual hardness	Check/adapt mixing screw if necessary	Check/adapt mixing screw if necessary	Check/adapt mixing screw if necessary	Check/adapt mixing screw if necessary	Check/adapt mixing screw if necessary
Electronic/ settings*	Check	Check	Check	Check	Check/replace if necessary
Transformer*	Check	Check	Check	Check	Check/replace if necessary
Turbine manifold****	Check and Clean	Check and Clean	Check and Clean	Check and Clean	Replace
Turbine cable	Check	Check	Check	Check	Replace
Valve watertightness	Check	Check	Check	Check	Check
Valve to piping watertightness	Check	Check	Check	Check	Check
Brine tank & brine well	Clean	Clean	Clean	Clean	Clean
Safety brine valve (if present)	Check and Clean	Check and Clean	Check and Clean	Check and Clean	Check and Clean
Brine tube	Clean	Clean	Clean	Clean	Clean
Brine line	Clean	Clean	Clean	Clean	Clean
Cabinet body and cover (external)	Clean	Clean	Clean	Clean	Clean

* Electronic parts - durability strongly affected by power source quality and stability.

** Elastomer durability is strongly affected by raw water concentration in chlorine and its derivative.

*** 368 being not equipped with an Aircheck, therefore the safety brine valve should be equipped with and aircheck.

**** Wear part.

8.2.1 Maintenance instructions

- Disinfect and clean the system at least once a year or if the treated water has an off-taste or an unusual odour.

8.3 Adding salt

Tip



Do not fill the brine tank with too much salt if you are approaching to brine tank cleaning date.

Info



Note

The following procedure describes the steps to be performed for a Riversoft 30 system. Depending on your softener (4, 8, 15 or 30), the steps may be slightly different but the principle remains the same.

1. Open the softener lid **(3)**.
 - ⇒ If necessary the top protective cover **(4)** can be fully removed.
2. Open the salt lid **(2)**.
3. Make sure the brine well **(1)** is closed by its cap.
4. Dump salt in the funnel **(5)** leaving the brine well **(1)** uncovered for a minimum of 2 cm.
5. Close the salt lid **(2)**.
6. Close the softener lid **(3)**.
 - ⇒ If necessary remount the top protective cover **(4)**.

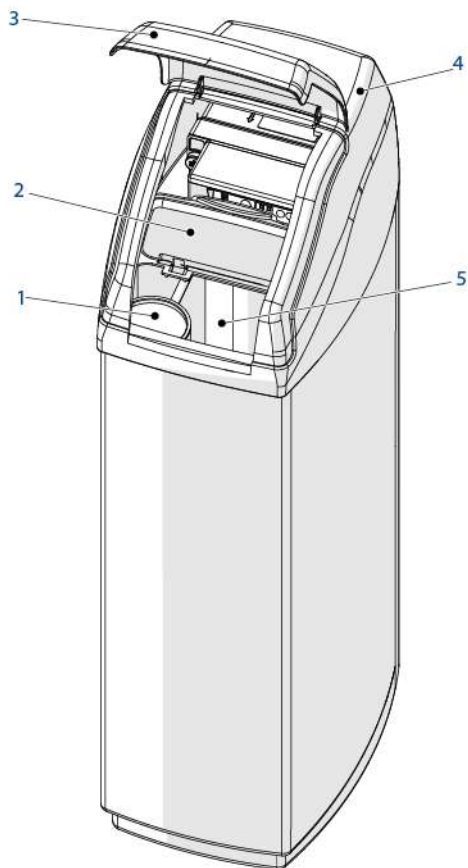

8.4 Recommendations

8.4.1 Use original spare parts

Caution - material



Risk of damage due to use of non-genuine spare parts

To ensure correct operation and safety of the device, only use original spare parts and accessories recommended by the manufacturer.

Usage of non-genuine spare parts voids all warranties.

Parts to keep in stock for potential replacements are motor and optical sensor, controller, transformer, injectors, flapper kit, o-ring kit, refill controller and DLFC.

8.4.2 Use original approved lubricants

- Production:
p/n 1014082 (NFO "Chemplex" 862 Silicone Comp.);
- spare part:
p/n 42561 (SILICONE LUBRICANT PACK).

8.5 Cleaning and maintenance

8.5.1 First steps

Before any cleaning or maintenance procedure, complete the following steps:

Mandatory



These operations must be performed before any cleaning or maintenance procedure!

1. Unplug the wall-mounted transformer.
2. Shut off water supply or put bypass valve(s) into bypass position.
3. Relieve system pressure before performing any operations.

8.5.2 Covers removal (softener and valve)

CAUTION



Do not pull on the cables.

Release the connectors from controller (2) by pressing on their locking clips.

1. Remove the softener cover (1).
2. Turn the locking clip (3) on the left to unlock the controller (2).
3. Remove the front cover (2) from the valve body (4).

Caution - material



Caution

Be careful with cables connections when disassembling the controller (2).

4. Reverse above procedure steps to rebuild. See Controller connection [→Page 41].

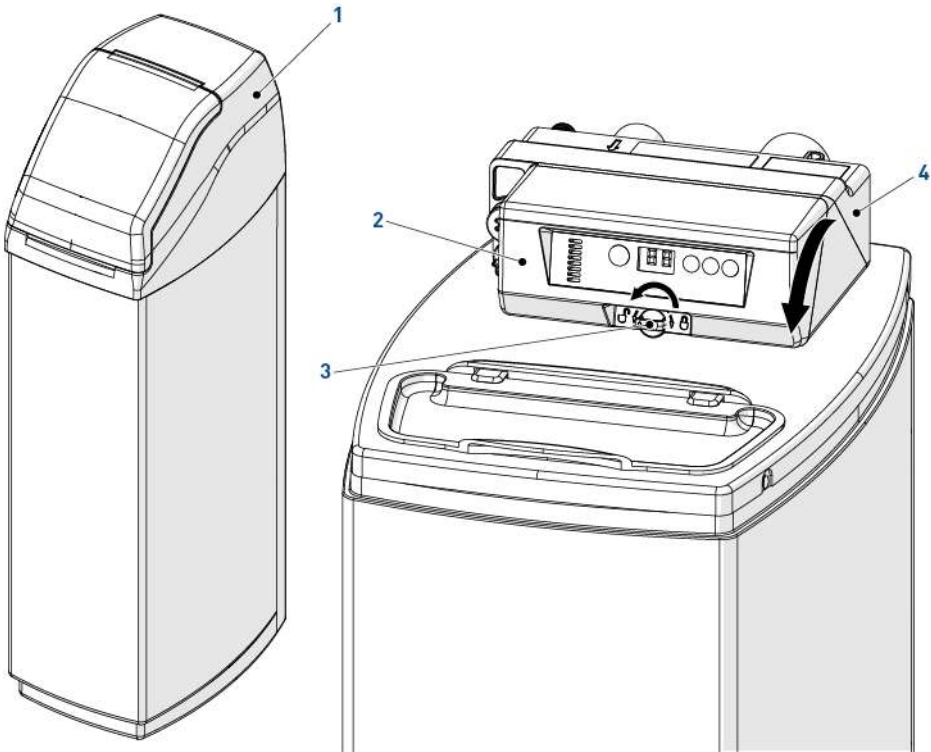

8.5.3 Brine tank and brine well cleaning

1. Remove the softener cover (1).
2. Open the brine tank cover (4).
3. Remove the remaining salt from brine tank (5).
4. Remove the brine well cover (3).
5. Remove the remaining brine from brine well (2).
6. Clean the brine tank (5) and the brine well (2) with water and sponges.

 CAUTION



Do not lay down or flip over the softener to empty the brine tank.

7. Using a water vacuum, remove the cleaning waste and remaining water from brine tank (5) and from brine well (2).
8. Refit the brine well cover (3).
9. Fill the brine tank (5) with salt, see Adding salt [→Page 57].
10. Close the brine tank cover (4).
11. Refit the softener cover (1).

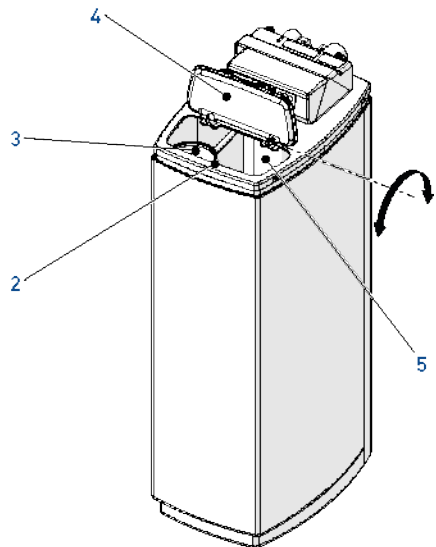
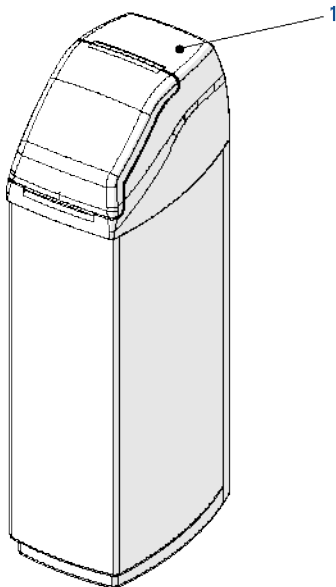

8.5.4 Cleaning the injector screen

1. Remove the softener cover, see Covers removal (softener and valve) [->Page 60].
2. Using a Torx key, unscrew and extract the refill flow controller **(3)**.
3. Clean the refill flow controller **(3)** using compressed air or with a soft brush.
 - ⇒ Make sure the refill controller groove is perfectly clean.
4. Check for O-rings integrity.
5. Check for ball **(2)** integrity (if present).
6. Clean the refill flow controller chamber **(1)** before reinserting the refill flow controller **(3)** and its ball **(2)**.
7. Reverse above procedure steps to rebuild.

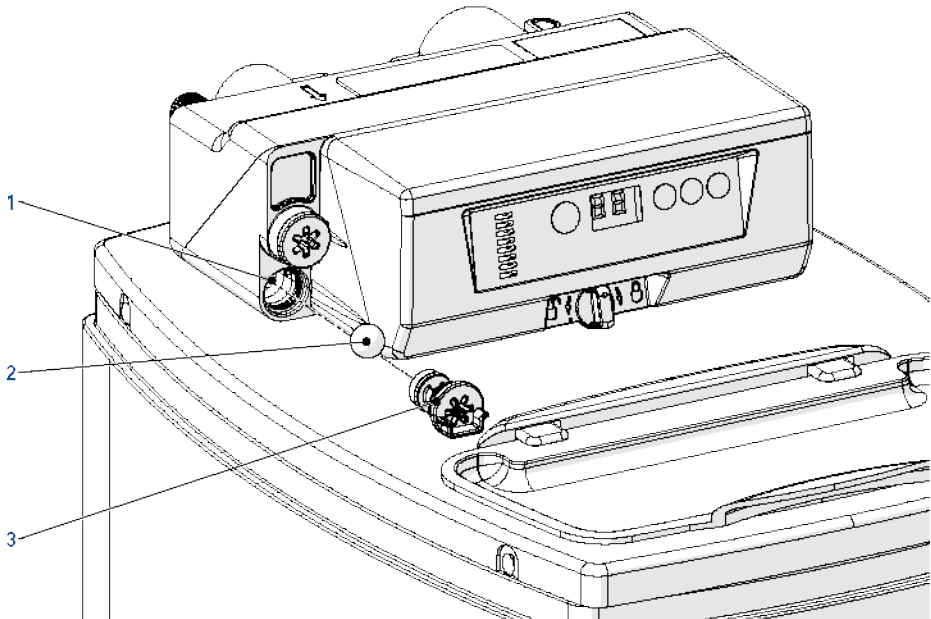

8.5.5 Cleaning the injector

1. Remove the softener cover, see Covers removal (softener and valve) [→Page 60].
2. Using a Torx key, unscrew and extract the injector cap (3).

CAUTION

! Take care not to damage the injector (2).

3. Using pliers, gently extract the injector (2) from valve body.
4. Unclip the injector screen (1) from the injector (2).
5. Clean the injector (2) using compressed air, a soft brush or possibly a pin.
6. Clean the injector screen (1) with a soft brush.

Info



Note

Use of descaling agent such as white vinegar might be required in case of impurities or scale on the injector screen (1) and on the injector (2).

7. Check for o-rings integrity.
8. Assemble the injector screen (1) on the injector (2).
9. Rinse thoroughly any cleaning agent you may have used.
10. Reverse above procedure steps to rebuild.

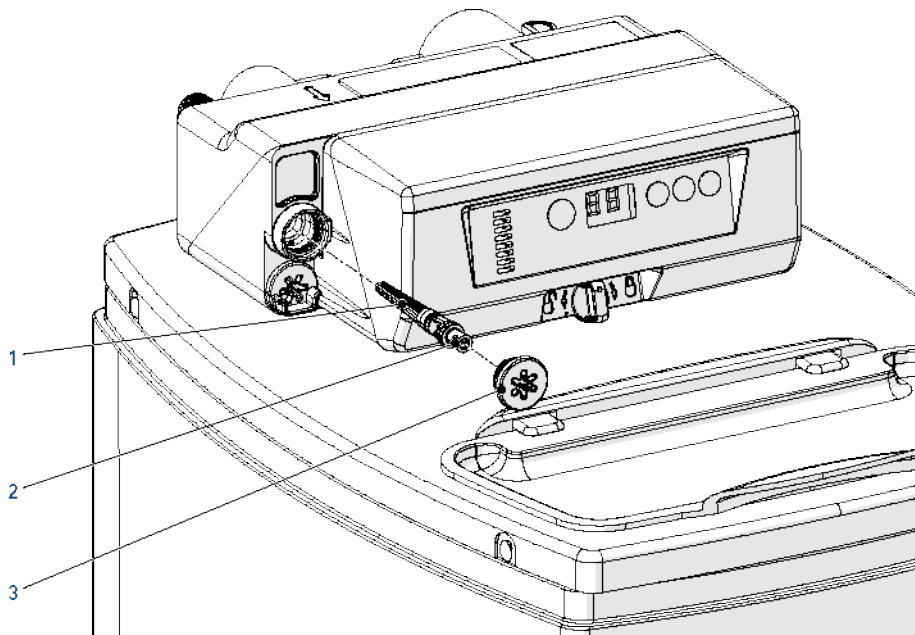

8.5.6 Controller replacement

1. Remove the softener and valve covers, see Covers removal (softener and valve) [→Page 60].

CAUTION



Do not pull on the cables.

Release the connectors (1) from controller by pressing on their locking clips.

2. At the back of the front cover, unscrew the four screws (4).
3. Remove the protective plate (3) and change the controller (2).
4. Connect the new controller, see Controller connection [→Page 41].
5. Reverse above procedure steps to rebuild.

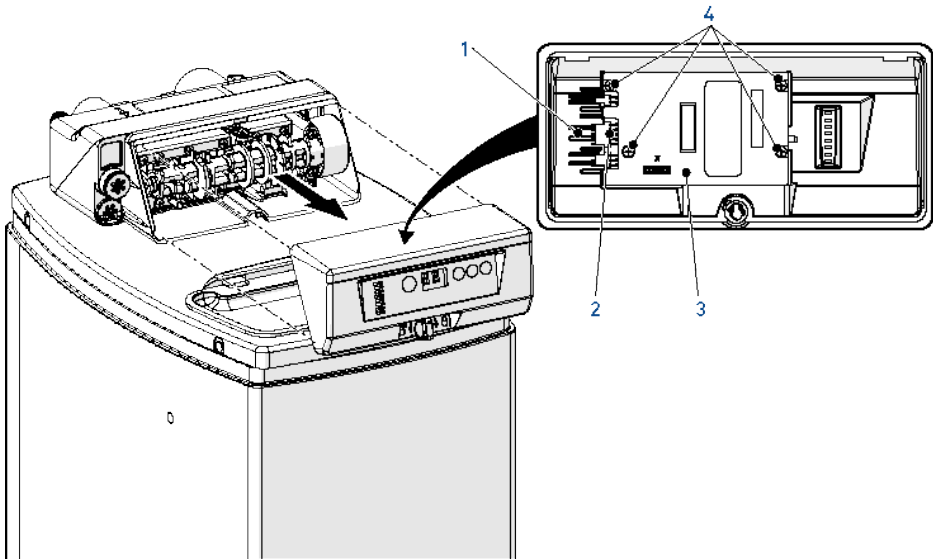

8.5.7 Other wear and tear parts

8.5.7.1 Cleaning the backwash flow controller

Info



The following procedure is only applicable in the bypass configuration.

1. Remove the softener cover, see Covers removal (softener and valve) [→Page 60].
2. Remove the clip **(1)**.
3. Unscrew the backwash controller **(4)** by hand.

Caution - material



Pay attention to not lose the backwash controller ball **(3)** that is inside.

4. Clean the backwash controller **(4)** using a soft brush or compressed air.
5. Clean the backwash controller grooves and backwash controller chamber **(2)**.
6. Reverse above procedure steps to rebuild.

Info



Remember to put the backwash controller ball **(3)** inside the plug when reassembling.

Caution - material



When reassembling the backwash controller **(4)**, slowly screw by hand.

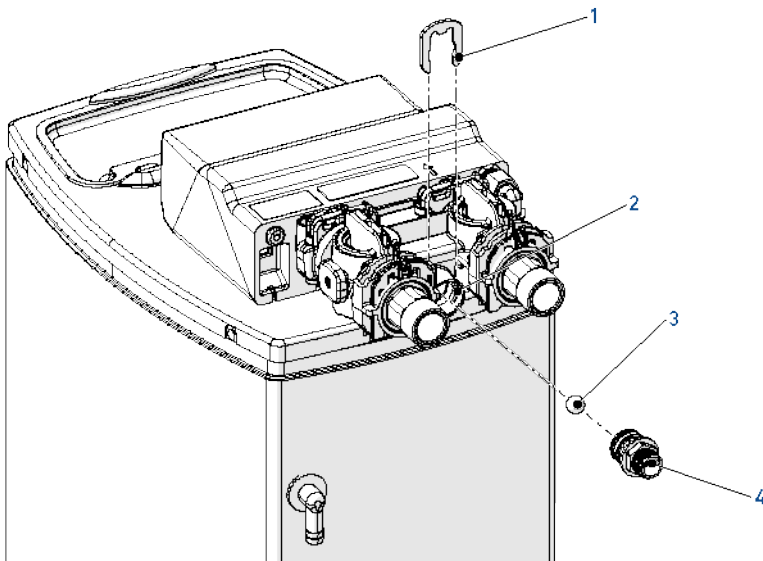

8.5.7.2 Manifold/bypass removal

Info



Depending on the installation configuration, the valve may be equipped with a manifold or a bypass. The following procedure applies to both configurations.

1. Remove the softener cover, see Covers removal (softener and valve) [→Page 60].
2. Remove the "U" clips (1) (a screwdriver can be used as a lever if required).
3. Remove the manifold/bypass (2) from the valve body (3).

Bypass configuration

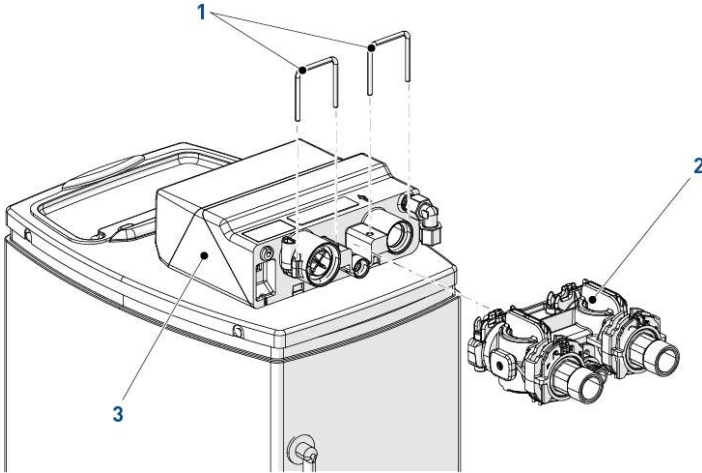

Manifold configuration

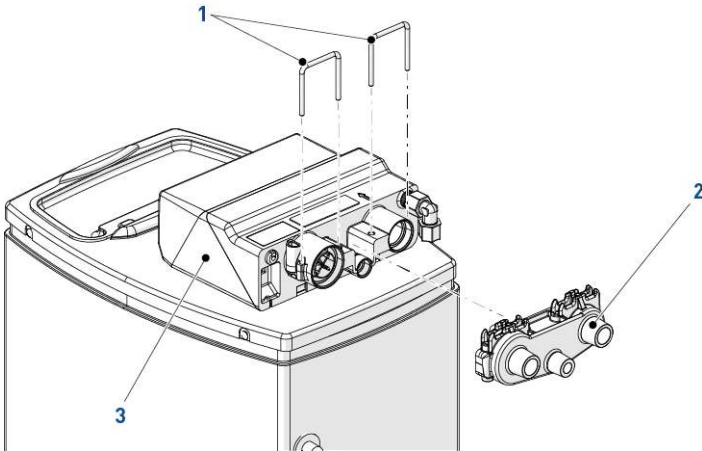

8.5.7.3 Motor and camshaft replacement

1. Remove the softener and valve covers, see Covers removal (softener and valve) [→Page 60].
2. Disconnect the motor **(2)** from the optical sensor **(1)**.
3. Loosen the two screws **(4)** and remove the clamp **(3)**.
4. Remove and disassemble the camshaft **(5)** from the motor **(2)**.
5. Change motor **(2)** and/or camshaft **(5)**.
6. Reverse above procedure steps to rebuild.

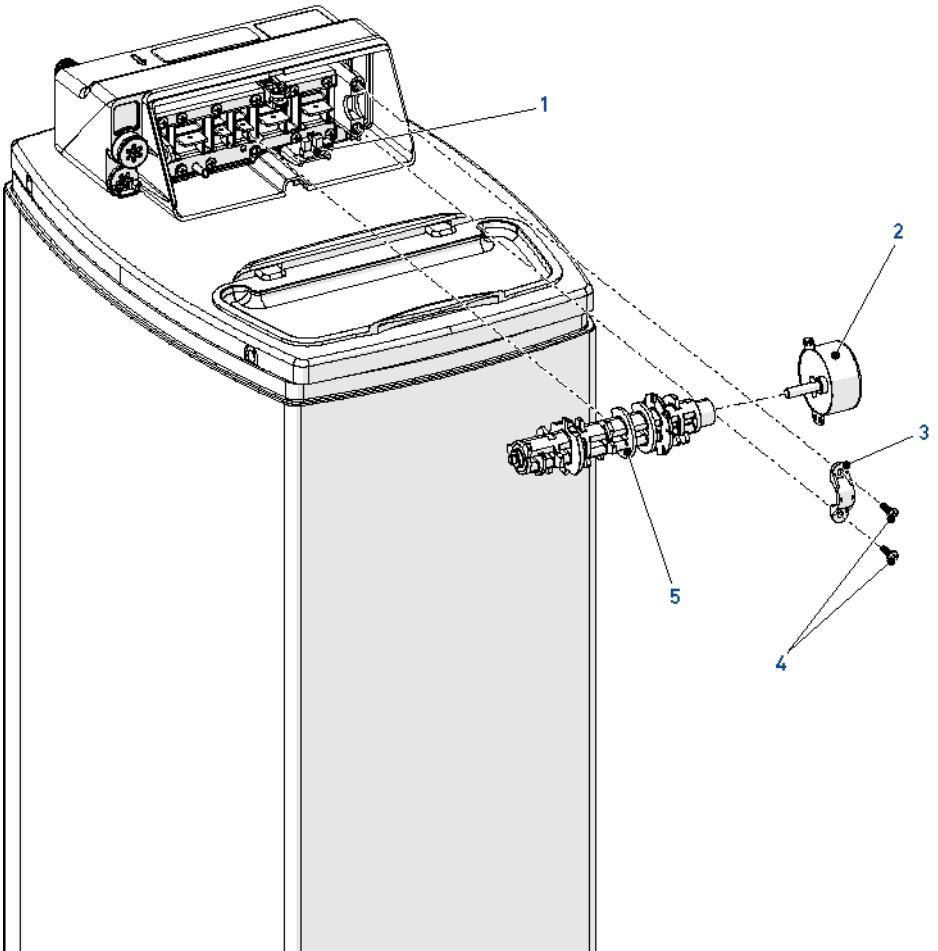

8.5.7.4 Optical sensor replacement

1. Remove the softener and valve covers, see Covers removal (softener and valve) [→Page 60].
2. Remove the motor and camshaft, see Motor and camshaft replacement [→Page 67].
3. The optical sensor (1) is clipped on the front edge of the top plate, gently press on the clips to release the optical sensor (1) from its location.
4. Change the optical sensor (1) and reverse above procedure steps to rebuild.

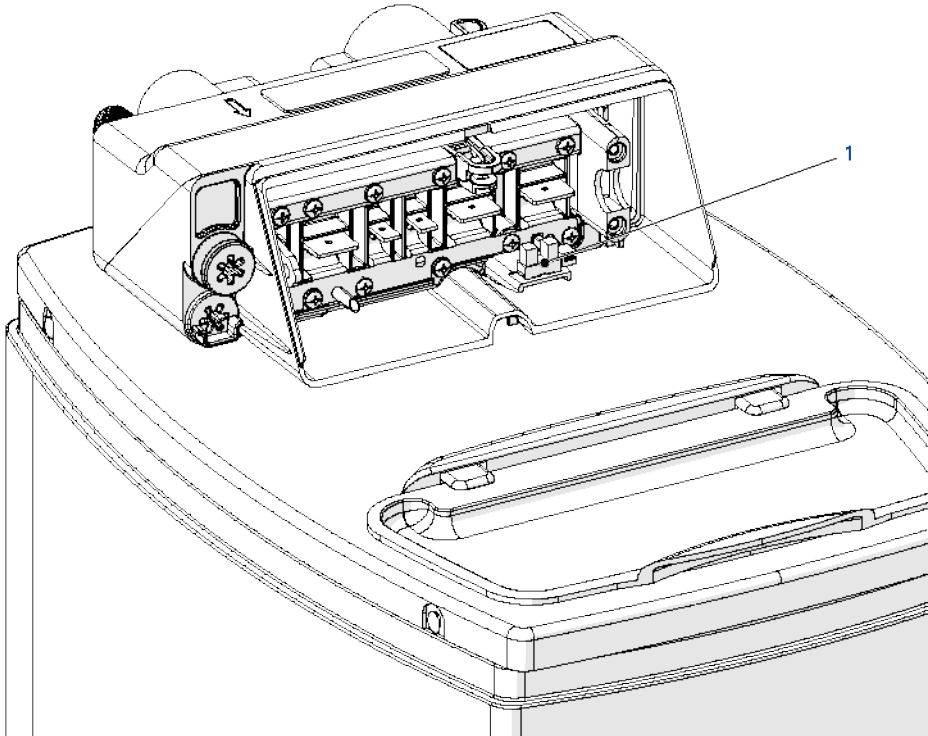

8.5.7.5 Cleaning/replacing flappers

1. Remove the softener and valve covers, see Covers removal (softener and valve) [→Page 60].
2. Remove the motor and camshaft, see Motor and camshaft replacement [→Page 67].
3. Remove the optical sensor, see Optical sensor replacement [→Page 68].

CAUTION



Use of protective glove is highly recommended to remove the spring (4).

Beware of sharp edges when unmounting the flapper spring.

4. Loosen the four screws (5).
5. Using a flat screwdriver, release the flapper springs one by one and then remove the spring (4).
6. Loosen all top plate screws (3).
7. Remove the top plate (2) from the valve.
8. Clean or replace the flappers (1) if needed.

Info



The outline of the flapper seat can be seen on the flapper side. If the outline is irregular, this may indicate that debris is or has been preventing the flapper (1) from closing, and potential damages.

9. Remount flappers (1).
10. Once all flappers (1) are back in place, position the top plate (2) and screw it back following the figure order in green.
11. Position the one-piece spring (4) back to its place, locking it on its mounting pin and pads. Screw it back following the figure order in red.
12. Using a small flat screw driver, push on each part of the spring (4) to clip it back into the flappers (1) lever.
13. Remount the optical sensor, see Optical sensor replacement [→Page 68].
14. Remount the motor and camshaft, see Motor and camshaft replacement [→Page 67].
15. Remount the softener and valve covers, see Covers removal (softener and valve) [→Page 60].

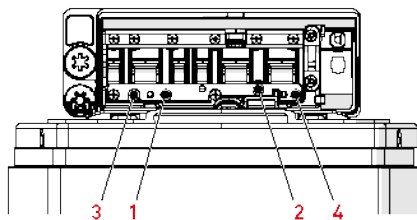
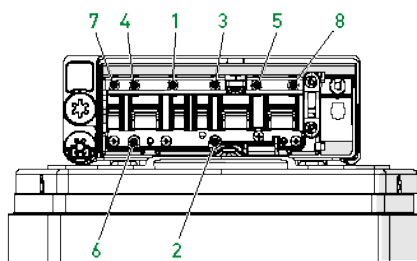
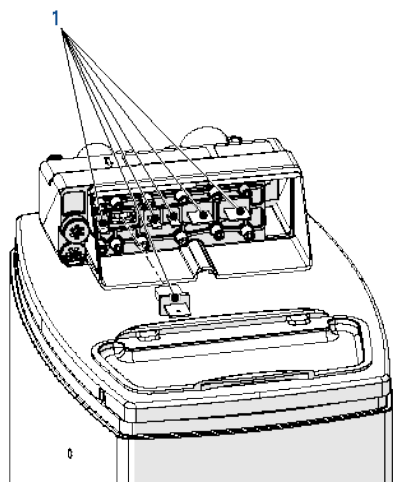
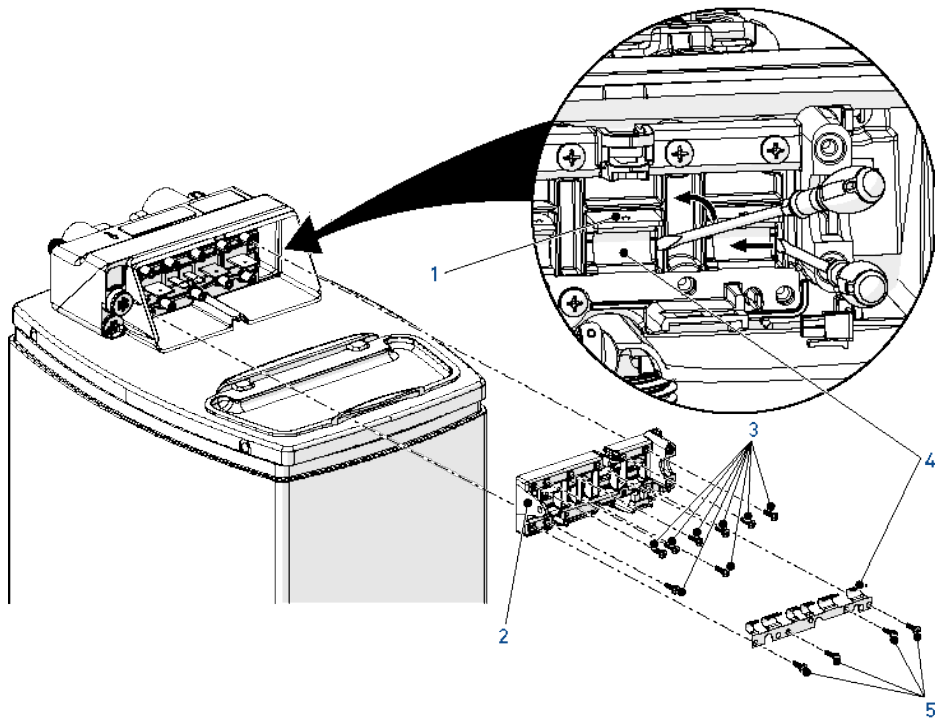

8.5.7.6 Disassembling/assembling valve from/on tank

1. Remove the softener cover, see Covers removal (softener and valve) [→Page 60].
2. Release the tube **(2)** from push-fit fitting **(1)**.
3. Unscrew, counter-clockwise, the valve **(4)** from tank **(3)**.
4. Perform maintenance or change the valve **(4)**.
5. Lubricate the valve tank adapter and riser tube O-rings with approved lubricant only.
6. Spin the valve **(4)** onto the tank **(3)**, ensuring the threads are not cross-threaded.
7. Rotate the valve **(4)** clockwise and freely, without using force until it comes to a stop.

Info



This stop position is considered point zero.

8. Rotate the valve **(4)** clockwise from point zero to between $\frac{1}{4}$ turn and $\frac{1}{2}$ turn.

Caution - material



Torque limitation

Do NOT exceed 27 Nm of torque when installing the valve. Exceeding this limit may damage the threads and cause failure.

9. Reverse steps **1** and **2** to rebuild.

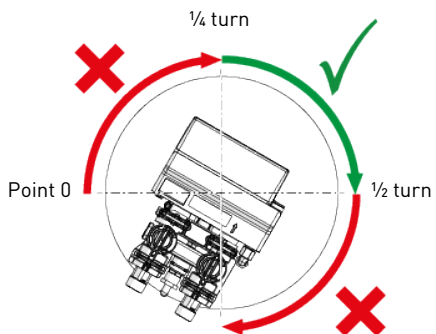
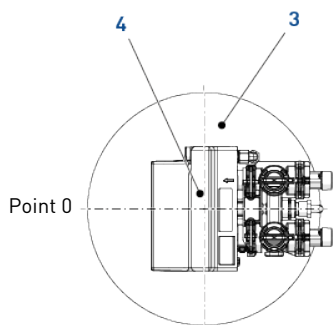
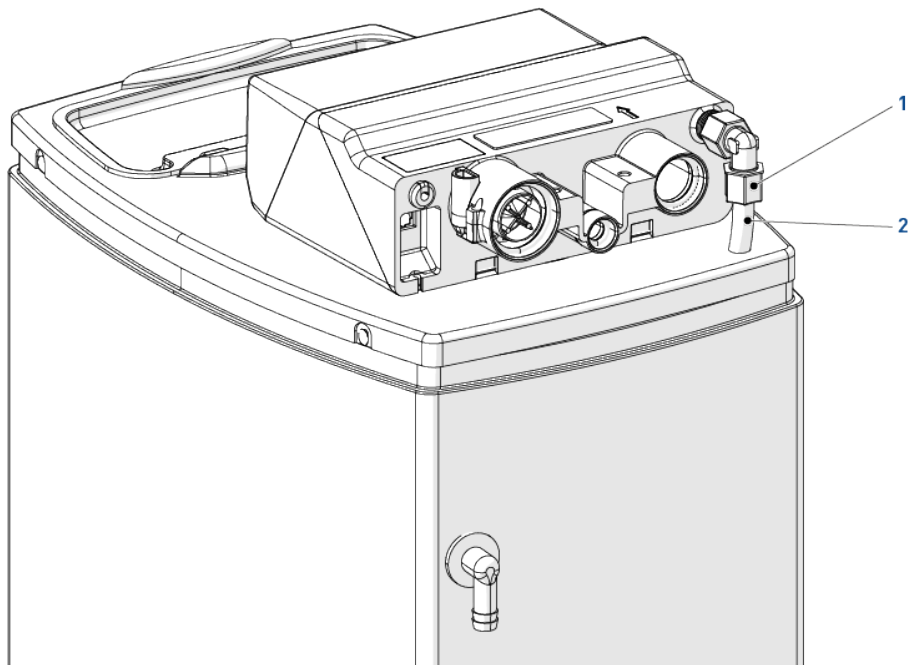

9 Troubleshooting

9.1 Controller

Err. code	Cause	Solution
E 1	Program settings have been corrupted.	Press any button. If "E 1" does not clear. Replace the controller.
E 2	Controller power does not match 50 or 60 Hz.	Disconnect and reconnect the power. If problem is not solved, replace controller and/or AC transformer.
E 3	Controller does not detect the camshaft position and is returning to the service position.	Wait until the controller returns to the service position.
	Camshaft is not turning during "E 3" display.	<p>Check if the motor is connected. Verify that the motor wire harness is connected to the motor and to the controller module. Verify if the optical sensor is connected and in place. Verify if the motor gear has engaged the camshaft.</p> <p>If everything is connected, replace components in this order:</p> <ol style="list-style-type: none"> 1. Motor Assembly and optical Sensor. 2. Controller.
	Camshaft is turning more than 5 minutes to find Home position.	<p>Verify if the optical sensor is in place and connected to wire. Inspect for debris in the camshaft slots. If the motor continues to rotate indefinitely, replace the following components in this order:</p> <ol style="list-style-type: none"> 1. Optical Sensor. 2. Control.

9.2 Valve

Issue	Cause	Reset and recovery
Flowing or dripping water at drain or brine line after regeneration.	Valve disc cannot close because of debris.	Remove debris.
	Valve stem return spring is weak.	Replace the spring. See Cleaning / replacing flappers [→Page 69].
Valve will not draw brine.	Restricted drain line.	Change drain to remove restriction.
	Injector plugged.	Clean injector and screen. See Cleaning injector screen [→Page 62].
	Debris is preventing complete opening or flapper is damaged.	Check flapper, clean seat and flapper, replace if necessary.
Controller will not regenerate automatically.	AC adapter or motor are not connected.	Connect the power source.
	Defective motor.	Replace the motor. See Motor and camshaft replacement [→Page 67].
	Meter clogged with debris.	Remove and clean the meter.
Controller regenerates at wrong time of day.	Time of day set incorrectly.	Set correct the time of day. See Time of day [→Page 43].
Intermittent or irregular brine draw.	Low water pressure.	Set pump or pressure regulator to maintain 1.38 bar (20 psi) dynamic at softener's inlet.
	Defective injector.	Replace injector.
Backwashes or purges at excessively low or high rate.	Incorrect drain controller used.	Replace with a correct size.
	Foreign matter affecting valve operation.	Remove drain control and clean ball and seat.

9.3 System

Issue	Cause	Solution
Hard water leakage after regeneration.	Improper regeneration.	Control brine dosage setting and repeat regeneration.
	Leaking of external bypass valve.	Replace bypass valve.
	O-ring around riser pipe damaged.	Replace o-ring.
	Incorrect controller settings.	Check that controller setting match with your actual softener model.
No conditioned water after regeneration.	No brine in brine tank.	Add brine to brine tank.
	Injector plugged.	Clean the injector and screen. See Cleaning injector screen [→Page 62].
Flow indicator on controller does not display service flow.	Bypass valve in bypass position.	Shift bypass valve to non-bypass position. See Bypassing [→Page 34].
	Meter probe disconnected or not fully connected to meter housing.	Fully insert probe into meter housing.
	Restricted meter turbine rotation due to foreign matter in meter.	Remove meter housing, free up turbine and flush with clean water. Turbine should spin freely. If not, replace meter.
Run out of conditioned water between regenerations.	Controller improperly programmed.	Verify salt dosage and regeneration interval settings. See Programming [→Page 42].
	Restricted meter turbine rotation due to foreign matter in meter.	Remove meter housing, free up turbine and flush with clean water. Turbine should spin freely. If not, replace meter.
Brine tank overflow.	Improper drain control for injector.	Use of small drain control with larger injector will reduce draw rates.
	Drain control clogged with resin or other debris.	Clean drain control.

10 Spare parts

Info



Note

There are no user serviceable parts in the AC wall mount adapters, motor or control board.

10.1 Softener

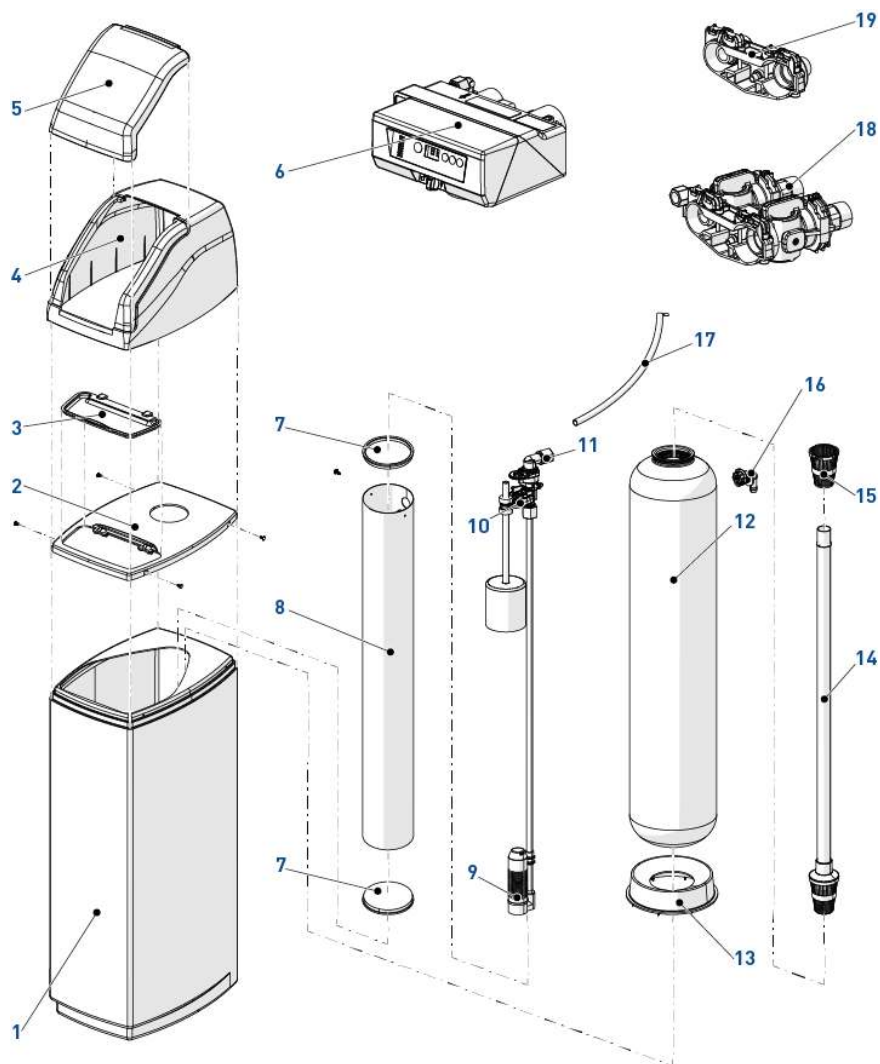

Item	Part number	Description	Package quantity
1	CABSMAW	Cabinet body for 30 model	1
-	CABMAXWNB	Cabinet body for 15 model	1
-	CABMINWNB	Cabinet body for 8 model	1
-	CM-BODY	Cabinet body for 4 model	1
2	CABPLATELP	Cabinet plate for 30 model	1
-	CM-COV13	Cabinet plate for 4 model	1
3	CABLIDLP	Brine tank cover for 30 model	1
-	CABLID232BK	Brine tank cover for 15 and 8 models	1
-	CM-LID	Brine tank cover for 4 model	1
4	CABCOVCYWH	Softener back cover for 30, 15 and 8 models	1
5	CABCOVCYLID	Softener front cover for 30, 15 and 8 models	1
6	368606H14#9-EU	Autotrol 368 valve for Riversoft 30 model (no bypass)	1
-	368606BPJ33#10-EU	Autotrol 368 valve for Riversoft 30 model (with bypass)	1
-	368606F14#7-EU	Autotrol 368 valve for Riversoft 15 model (no bypass)	1
-	368606BPF14#7-EU	Autotrol 368 valve for Riversoft 15 model (with bypass)	1
-	368606G14#8-EU	Autotrol 368 valve for Riversoft 8 model (no bypass)	1
-	368606BPG14#8-EU	Autotrol 368 valve for Riversoft 8 model (with bypass)	1
-	368606E14#6-EU	Autotrol 368 valve for Riversoft 4 model (no bypass)	1
-	368606BPE14#6-EU	Autotrol 368 valve for Riversoft 4 model (with bypass)	1
7	E02588	Brine well cap for 30 and 15 models	2
8	E02231	Brine well for 30 and 15 models	1
-	E02131	Brine well for 8 model	1
9	18168	Air check 500 for 30 and 15 models	1
-	18168_Riversoft8	Air check 500 for 8 model	1
-	18168-L280	Air check 500 for 4 model	1
10	60067-03	Safety brine assembly for 15 model	1
11	27121	Union elbow 3/8" T - 3/8" T	1
12	DPEX735S	Tank for 30 and 15 models	1
13	CM-BASE13	Tank base support for 4 model	1
-	Q-0818-A8	Tank for 8 model	1
-	Q-0613-A8S	Tank for 4 model	1
14	27827	Riser tube for 30 and 15 models	1
-	3028254	Riser tube for 8 and 4 models	1

Item	Part number	Description	Package quantity
15	18280	Upper screen for 30 and 15 models	1
-	1009116	Upper screen for 8 model	1
16	E01180	Overflow elbow	1
17	E01480	Brine tube 3/8" x 34.75"	1
18	4000886	368 bypass, see Piping [→Page 80].	1
19	4000970	Manifold, see Piping [→Page 80].	1

10.2 Valve

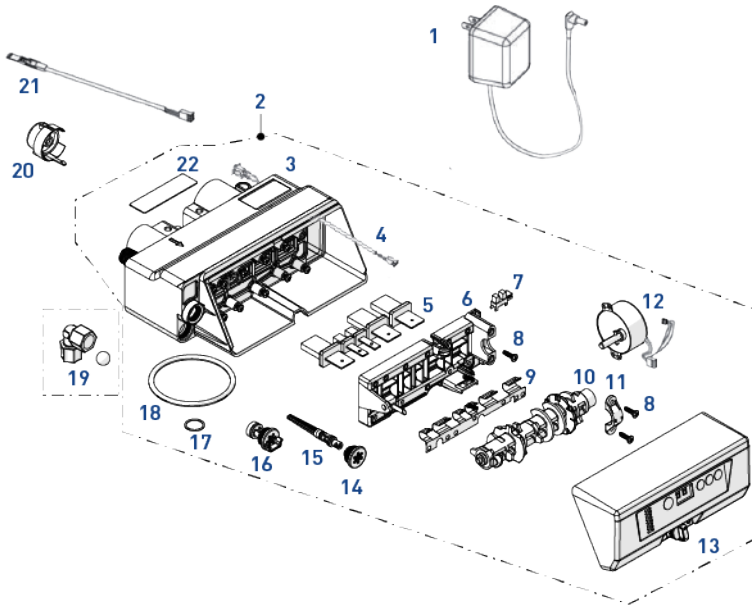

Item	Part number	Description	Package quantity
1	-	AC Wall Mount Adapters	-
-	1000813	230 VAC, 50 Hz, British plug	1
-	1000814	230 VAC, 50 Hz, European plug	1
2	-	Kit, service, valve 368-606b	-
-	4001891	Kit, service, valve 368-606b, 14, WD	1
-	4001893	Kit, service, valve 368-606b, 33, WD	1
3	3031018	Valve body assembly, volumetric includes items 4, 5, 7 and 8 (may be purchased separately).	1
4	4001260	12 volt motor/optical sensor cable assembly	1
5	3007947	Valve disc kit	1

Item	Part number	Description	Package quantity
6	3022012	Top plate	1
7	1235373	Module, sensor, photo interrupter	1
8	1234170	Top plate screw no 8 x 9/16"	10
9	3022017	Spring, top plate	1
10	3022014	Camshaft, 7 cycle	1
11	1000589	Pillow block cap	1
12	3026537	12 volt motor/cable assembly	1
13	4001738	606 controller for use with 0.14 gpm BLFC	1
-	4001742	606 controller for use with 0.33 gpm BLFC	1
14	1000269	Injector cap assembly	1
15	-	Injector/screen assemblies	-
-	3025326	"E" injector, yellow, 6" tank	1
-	3025327	"F" injector, peach, 7" tank	1
-	3025328	"G" injector, tan, 8" tank	1
-	3025329	"H" injector, lt purple 9" tank	1
-	4000880	"J" injector, lt blue 10" tank	1
16	-	Assembly refill flow controller	-
-	1000221	Assembly refill flow controller 0.14 gpm	1
-	1243510	Assembly refill controller - 0.33 gpm (required with 1030502)	1
-	1030502	Ball, brine-backwash, 0.557" diameter (required with 1243510)	1
17	1232370	O-ring, riser	1
18	1010154	O-ring, tank	1
19	-	Kit, drain line flow controller ½" BSPT/ball	-
-	3031526	Kit DLFC ½" BSPT #6	1
-	3031527	Kit DLFC ½" BSPT #7	1
-	3031528	Kit DLFC ½" BSPT #8	1
-	3031529	Kit DLFC ½" BSPT #9	1
20	3027839	Meter assembly	1
21	3027837	Meter cable	1
22	3038447	Label, locking bar warning	1

10.3 Piping

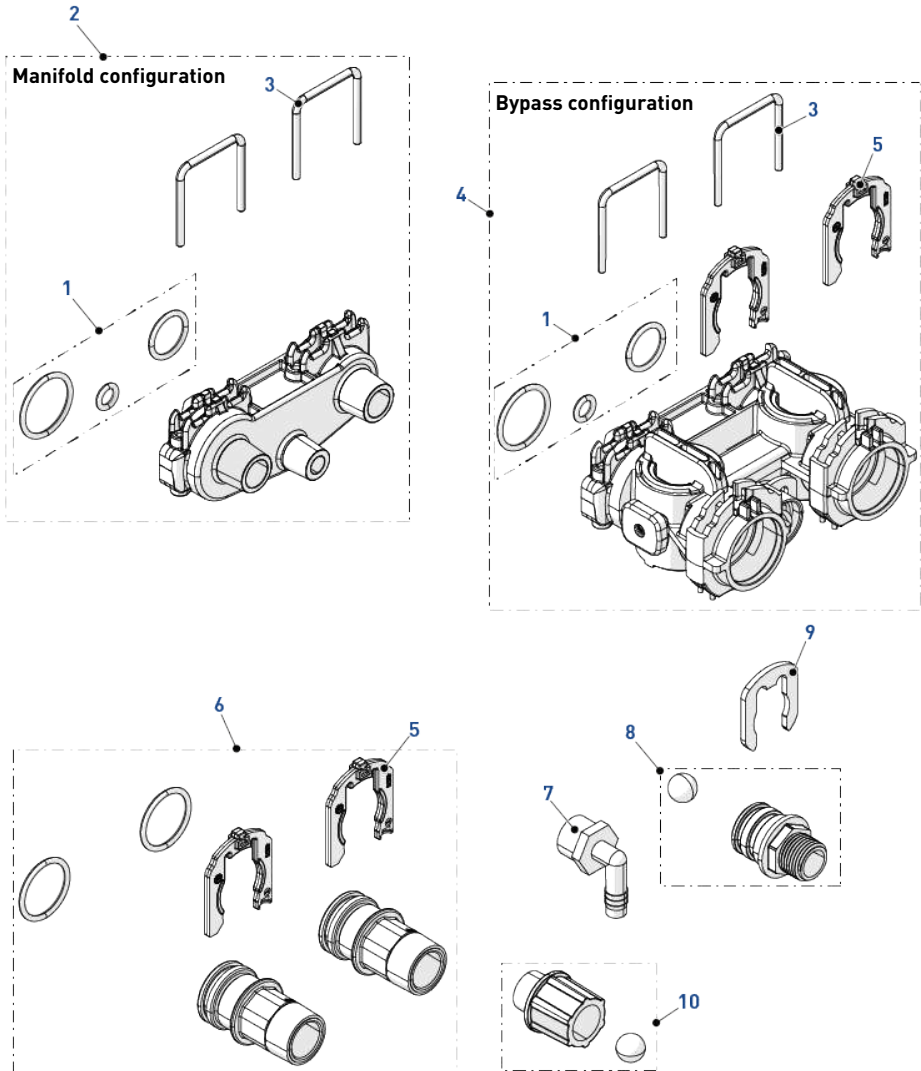

Item	Part number	Description	Package quantity
1	3031825	Kit, O-ring manifold	1
2	4000970	3/4" BSP adapter - black	1
3	3027832	Fixing clip	2
4	4000886	368 Bypass	1

Item	Part number	Description	Package quantity
5	40576	I/O clip	2
6	4001604	Kit, 1" BSP connectors	1
7	4000996	Drain elbow, plastic, 1/2"	1
8	-	Ext DLFC, bypass, BSP	-
-	4001297	#6 Ext DLFC, bypass, BSP	1
-	4001298	#7 Ext DLFC, bypass, BSP	1
-	4001299	#8 Ext DLFC, bypass, BSP	1
-	4001300	#9 Ext DLFC, bypass, BSP	1
-	4001545	#10 Ext DLFC, bypass, BSP	1
9	4000390	DLFC clip	1
10	-	Kit DLFC 1/2" BSPT	-
-	3031526	Kit DLFC 1/2" BSPT #6	1
-	3031527	Kit DLFC 1/2" BSPT #7	1
-	3031528	Kit DLFC 1/2" BSPT #8	1
-	3031529	Kit DLFC 1/2" BSPT #9	1

11 Disposal

The device must be scrapped in accordance with directive 2012/19/EU or the environmental standards in force in the country of installation. The components included in the system must be separated and recycled in a waste recycling center that conforms with the legislation in force in the country of installation. This will help to reduce the impact on the environment, health, safety and help to promote recycling. Pentair does not collect used product for recycling. Contact your local recycling center for more information.



Notes

WWW.PENTAIR.EU